



502 SERIES VPC BSP



Designed to act in case of hose breakage.
Block/Control charge's descent avoiding a sharp-fall pressure on the circuit.
BSP Threads, others available upon request.

• **Materials**

Carbon Steel EN -10277-3 / AISI 316L
Springs: Carbon Steel DIN 17233/84(B)

• **Sectors:** Industrial



• **Applications:** Designed for Oil hydraulic Applications.

MODEL STRUCTURE

Example:
502.19992AN

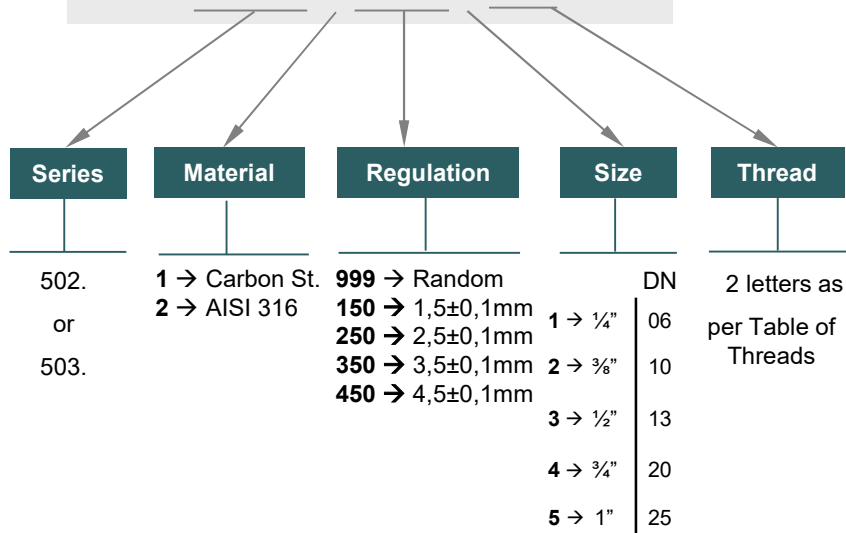

• Random regulation for VPC (999) although it is possible to regulate them upon request.



502 SERIES

VPC BSP



OPERATION:

In normal position the disc is driven by the spring allowing fluid passage from Z to Z1.
In normal conditions, the fluid returns also free to tank from Z1 to Z.

When the fluid passage increases from Z1 to Z, and the reaction flow exceeds, the disc blocks the return to tank, preventing uncontrolled descent.

The user can adjust the reaction flow (T), according to specific needs of this safety valve.

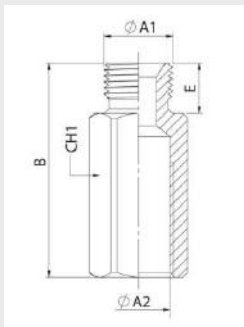

BODY M - F

DN	ØA1	ØA2	REF.	CH1	B	E
06	1/4" BSP M.	1/4" BSP	502.19991AM	19	50	12
10	3/8" BSP M.	3/8" BSP	502.19992AN	22	59	13
13	1/2" BSP M.	1/2" BSP	502.19993AO	27	65	15
20	3/4" BSP M.	3/4" BSP	502.19994AP	36	78	16
25	1" BSP M.	1" BSP	502.19995AQ	41	92	18

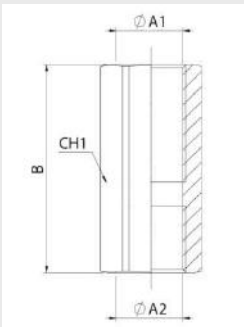

BODY F - F

DN	ØA1	ØA2	REF.	CH1	B
06	1/4" BSP	1/4" BSP	502.19991AB	19	48
10	3/8" BSP	3/8" BSP	502.19992AC	22	59
13	1/2" BSP	1/2" BSP	502.19993AD	27	62
20	3/4" BSP	3/4" BSP	502.19994AE	36	72
25	1" BSP	1" BSP	502.19995AF	41	86

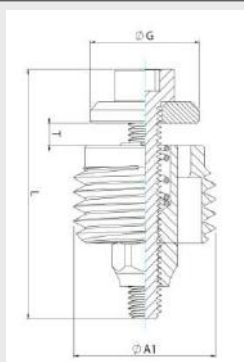

CARTRIDGE

DN	ØA1	REF.	ØG	L
06	1/4" BSP	503.19991AM	10	23
10	3/8" BSP	503.19992AN	13.80	23
13	1/2" BSP	503.19993AO	16	34
20	3/4" BSP	503.19994AP	20	34
25	1" BSP	503.19995AQ	24	43



★SPECIAL OPTIONS:

A hole for depressurization on the VPC valve can be delivered for minimum quantities upon request.
Adding a three number code at the end of the reference depending on the diameter of the hole.

Examples:

Ø6 mm → 060

Ø10 mm → 100

502-2



502 SERIES

VPC BSP



REACTION FLOW

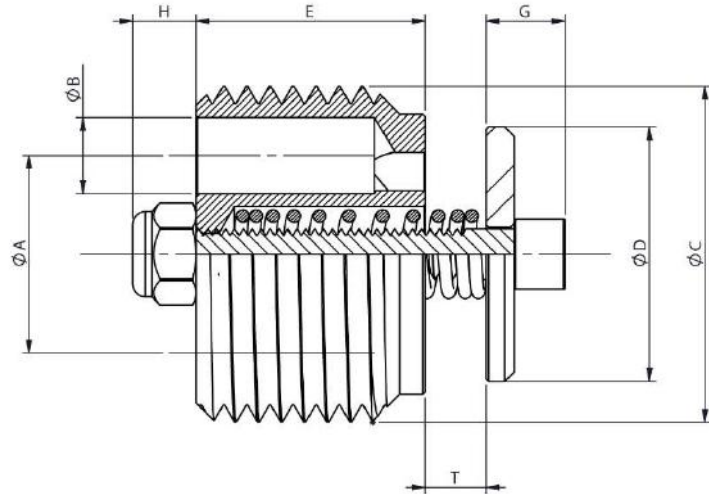

DN	Max. Flow Rate	Max. Pressure	A mm	B mm	C BSP	D mm	E mm	T mm	G mm	H mm
06	25 LPM	350 BAR	8.2	2.25	1/4"	10	9	See diagram below	5	4
10	50 LPM	350 BAR	11	3	3/8"	13.8	11		5	4
13	80 LPM	350 BAR	12	4.5	1/2"	16	13		5	5
20	150 LPM	350 BAR	15.5	6	3/4"	20	18		6.2	5
25	200 LPM	350 BAR	20	7	1"	24	21		7.5	5

Test performed according to ISO 18869

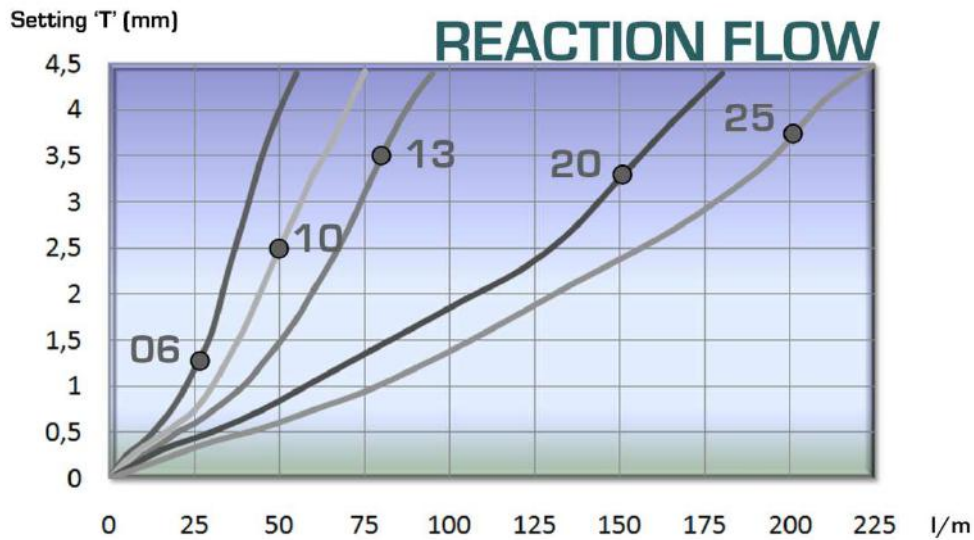

• Random regulation for VPC (999) although it is possible to regulate them upon request.

502-3

INTEVA reserves the right to make modifications in its products without prior notice. Any external or internal alteration in our products will automatically void the warranty.

