

432 SERIES

V3RH BSP / NPTF
ORB/ SAE



Calibrated steel manufacturing.
Available with or without mounting holes.
Thread combination available upon request of minimum quantities.

- **Materials**

Carbon Steel *EN -10277-3*
Seals: NBR, Viton or EPDM
Seating Ball: Poliamida 6.
Handle: ZAMAK-5

- **Applications:** Designed for Oil hydraulic Applications
Hammer Application

- **Equivalence**

PISTER BK3
MHA BK3
HYDAC KHB3K

- **Working temperature (O-ring)**

	NBR	Viton	EPDM
	+100°C	+200°C	+150°C
	-30°C	-10°C	-40°C

- **Sectors:** Industrial, Agricultural.



MODEL STRUCTURE

Example:

432.1113 AD

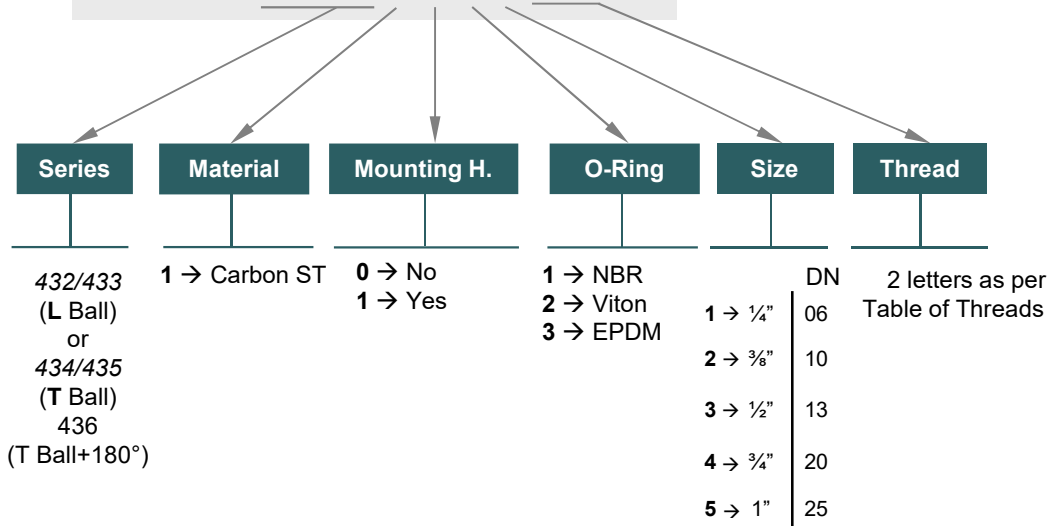

432-1



432 SERIES

V3RH BSP / NPTF
ORB/ SAE

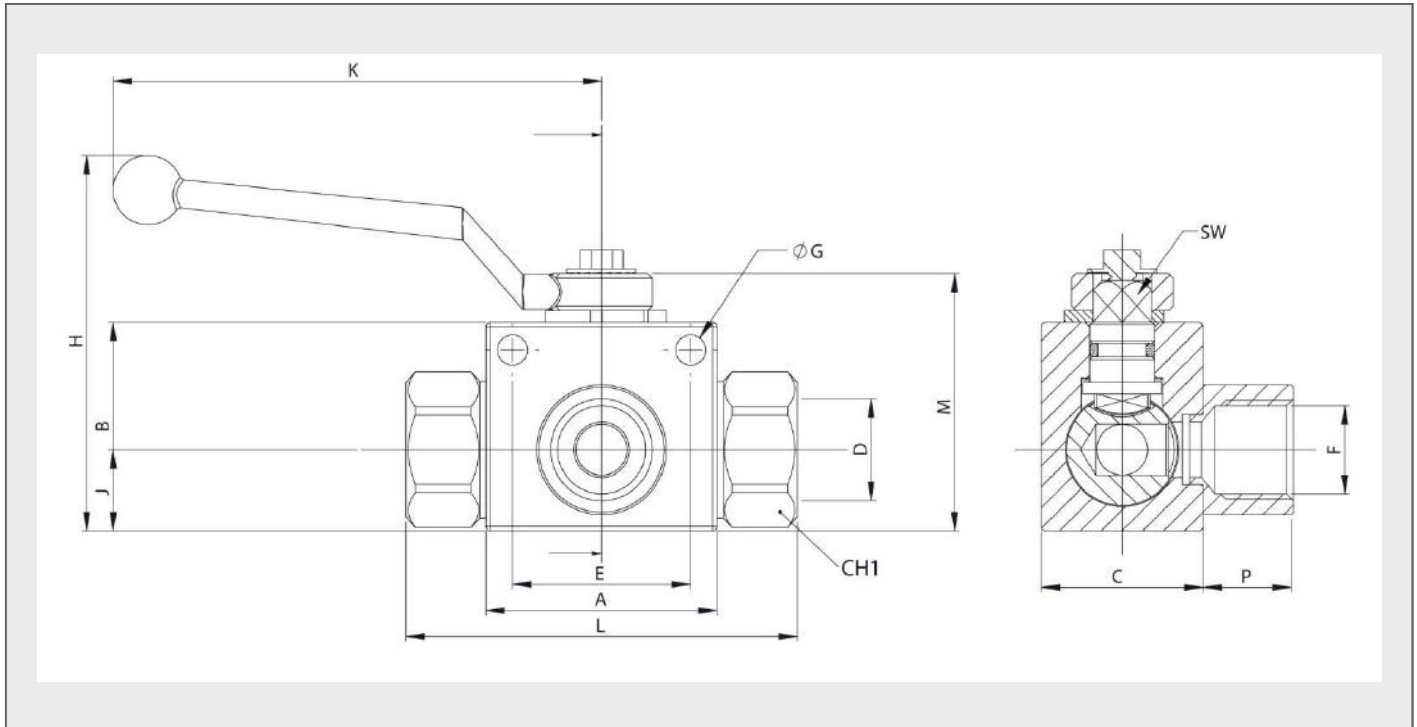

(A dimension)

STANDARD MODELS

DN	D / F	With M.H.	Without M.H.		CH1	L	A	B	M	K	H	J	C	SW	Ø G	E	P
06	1/4" BSP	432.1111AB	432.1011AB	500Bar	22	72,60	40	35	45,50	105,50	71	13	26	8,90	4,50	31,50	16
	1/4" NPTF	432.1111BB	432.1011BB														13
	7/16"-20h UNF(ORB)	432.1111GA	432.1011GA														14
10	3/8" BSP	432.1112AC	432.1012AC	500Bar	27	75,40	45	40	50,50	105,50	76	16	32	8,90	5,20	31,50	15
	3/8" NPTF	432.1112BC	432.1012BC														16
	9/16"-18h UNF(ORB)	432.1112GC	432.1012GC														16
13	1/2" BSP	432.1113AD	432.1013AD	500Bar	30	84,50	50	45	55,50	105,50	81	17,50	35	8,90	6,50	38,50	19,50
	1/2" NPTF	432.1113BD	432.1013BD														19,50
	3/4" - 16h UNF(ORB)	432.1113GF	432.1013GF														19,50
20	3/4" BSP	432.1114AE	432.1014AE	400Bar	41	93,40	60	60	73	159,50	108	23	50	13,90	6,50	48,50	19
	3/4" NPTF	432.1114BE	432.1014BE														21
	1 1/16"-12h UN(ORB)	432.1114GK	432.1014GK														21
25	1" BSP	432.1115AF	432.1015AF	350Bar	46	114,50	65	65	80	159,50	115	27,50	57	13,90	8,50	50,50	25
	1" NPTF	432.1115BF	432.1015BF														25
	1 1/4" BSP	432.1115AG	432.1015AG														31
	1 1/4" NPTF	432.1115BG	432.1015BG														25
	1 1/2" BSP	432.1115AH	432.1015AH														32
	1 1/2" NPTF	432.1115BH	432.1015BH														25
	1 5/16"-12h UN(ORB)	432.1115GO	432.1015GO														25

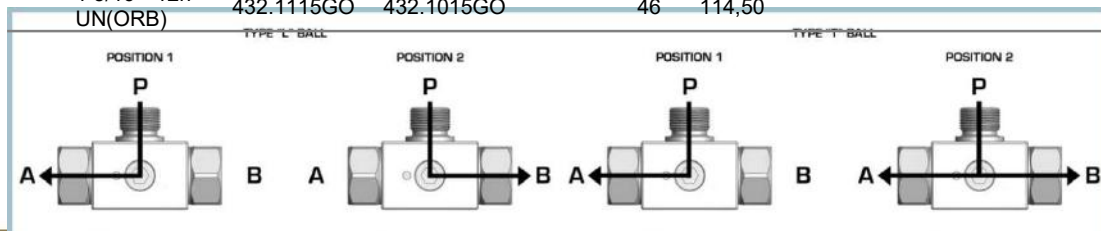

432-2