

Series SMS1000

Pressure Switch

- Compact and unified pressure switch.



Standard Specifications

Fluid	Air
Ambient and Fluid Temperature (°C)	-5~60(23~140°F)(Non-Freezing)
Operating Pressure Range (MPa)	0.1~0.4(15~60psi)
Proof Pressure (MPa)	1.0(140psi)
Max. Pressure (MPa)	0.7(100psi)
Hysteresis (MPa)	0.16(24psi)
Scale Variation (MPa)	±0.05(7psi)
Repeatability (MPa)	±0.05(7psi)
Contact	1a
Lead Wire Length	1m(39.7in)Standard(Grommet Type)
Port Size (R(PT), NPT)	1/8"
Weight (kg)	0.042(0.09lb)

Auto-Switch Specification

Applied Model	W8H	
Voltage	DC24V	AC110V
Electric Current	5~40mA	5~20mA

How to Order

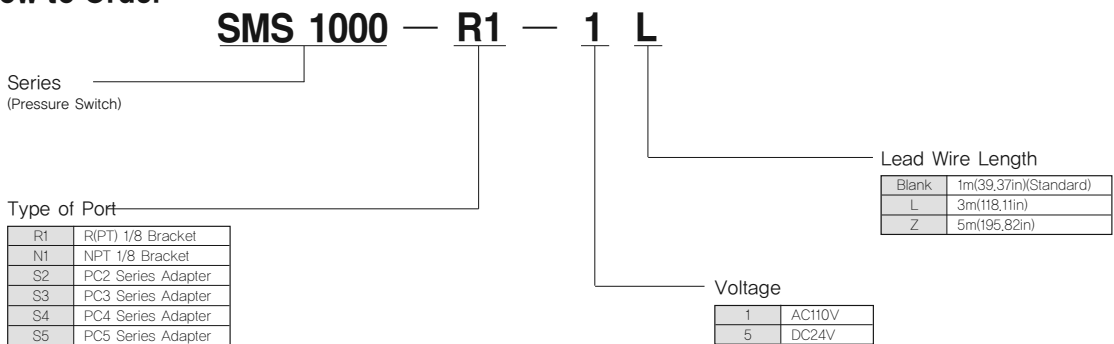

Series SMS

Construction

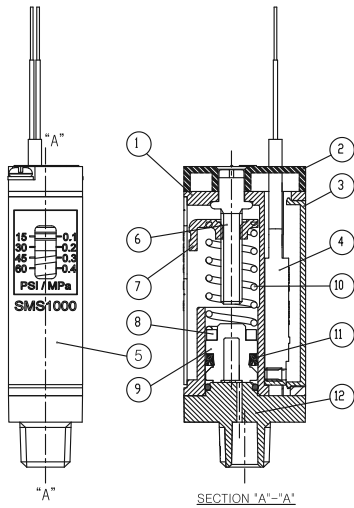

Main Parts List

NO.	Description	Material	Remark
①	Body	Nylon	
②	Top Cover	Resin	
③	Body Back Cover	Resin	
④	Auto Switch Ass'y	-	
⑤	Name Plate	Resin/Aluminum	
⑥	Adjustment Screw	Rolled Steel	
⑦	Pointer	Rolled Steel	
⑧	Magnet	Rare Earth Magnet	
⑨	Piston	Polyacetal	
⑩	Spring	SUS304	
⑪	Miniseal Y Type	NBR	
⑫	PT Fittings	Zinc Die Cast	

Dimensions

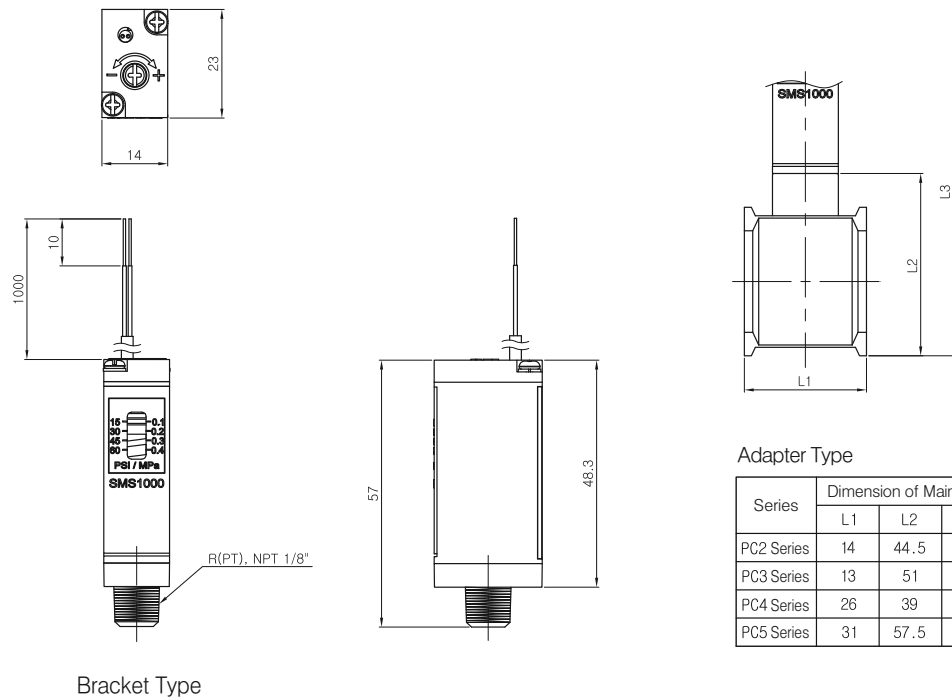

Adapter Type

Series	Dimension of Main Parts			Remarks
	L1	L2	L3	
PC2 Series	14	44.5	88	
PC3 Series	13	51	94.5	
PC4 Series	26	39	82	
PC5 Series	31	57.5	101	

PA

SSV

SMS1000

Accessories

OPTION

PER2000,
3000

PVR3000

PNR4000