

Series **NDM**

Direct Mount Cylinder/Standard Type: Double Acting Single Rod

Bore Size(mm) : Ø10, Ø16, Ø20, Ø25

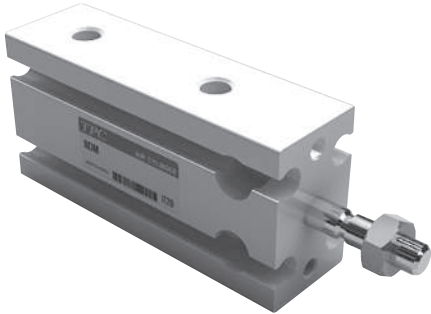

- COMPACT DESIGN SAVES SPACE
- MULTIPLE MOUNTING OPTIONS
- AUTO SWITCH TYPE AVAILABLE
- NON LUBRICATED SERVICE STANDARD

Symbol

Double acting



How to Order

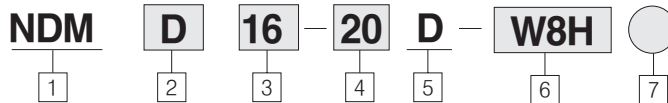

- 1 Direct Mount Cylinder
 - ※ Standard type
 - Built-in Magnet & Rubber Cushion
- 2 Blank : Without Magnet
D : Built-in Magnet
- 3 Bore size(mm)
 - 10 : φ 10
 - 16 : φ 16
 - 20 : φ 20
 - 25 : φ 25
- 4 Stroke(mm)
 - φ 10, 16 : 5, 10, 15, 20, 25, 30
 - φ 20, 25 : 5, 10, 15, 20, 25, 30, 40, 50
- 5 Action
D : Double acting

- 6 Auto Switch
 - Blank : None
 - W8H(V) : Reed Switch - 2 wire (DC24V, AC110V)
 - W9H(V) : Solid State Switch - 3 wire (DC24V)
 - ※ Standard Auto Switch lead wire length is 1m. 3m leads available on all models by adding a "L" suffix to the part number. Example W1H → W1HL
- 7 Number of Auto Switches
 - Blank : 2 pcs
 - S : 1 pc
 - N : N pcs

Series NDM

Minimum Operating Pressure Mpa(PSI)

Type \ Bore size(mm)	10	16	20	25
Double acting (Single rod)	0.06 (8.5psi)	0.06 (8.5psi)	0.05 (7.1psi)	0.5 (7.1psi)

Standard Specifications

Fluid	Air
Proof pressure	1.05MPa(149psi)
Max. operating pressure	0.7Mpa(99psi)
Ambient and fluid temperature °C(°F)	5 ~ 60°C(41~140°F)
Lubrication	Not required
Cushion	Both sides rubber cushion
Rod end thread	Male thread
Thread tolerance	KS 2 Class
Stroke allowance	+1.0 0
Mounting	Basic type

Standard Stroke (mm)

Bore size (mm)	Double acting Stroke							
	5	10	15	20	25	30	40	50
	10	○	○	○	○	○	○	-
16	○	○	○	○	○	○	-	-
20	○	○	○	○	○	○	○	○
25	○	○	○	○	○	○	○	○

Construction Parts List / Double Acting Single Rod

φ 10, 16

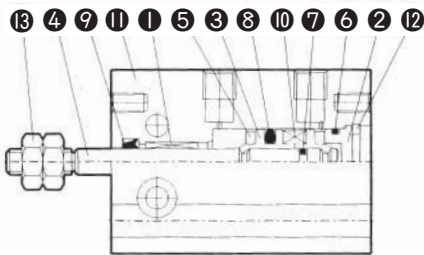

φ 20, φ 25

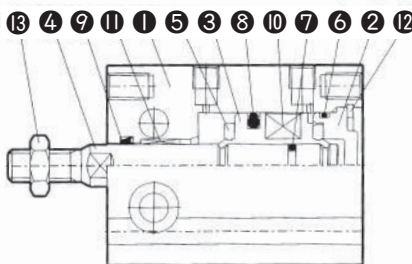

Parts List

No.	Description	Material	Note
1	Cylinder Tube	Aluminum alloy	Hard alumite
2	Head cover	Aluminum alloy	Hard alumite
3	Piston	Brass Aluminum alloy	
4	Piston rod	Stainless steel	
5	Bumper	Urethane	
6	Head Cover Gasket	NBR	
7	Piston Gasket	NBR	
8	Piston Packing	NBR	
9	Rod Packing	NBR	
10	Magnet	-	
11	Bush	Sintered oil bearing alloy	
12	Snap ring	Spring steel	Nickel plated
13	Rod End Nut	Carbon steel	

ACP

APM

AS

AX

AM2

AM

AL
ALX

AQ
ADQ

AQ2
ADQ2

AJ
AJM

ABK

ACK1

NSK

AG

NGQ

AGX
GX

NP

ADR

AMR

NDM

ARD

NST

AST

ASTH

NLCD

NLCS

Series NDM

Dimensions Double Acting/Single Rod

Ø10, Ø16

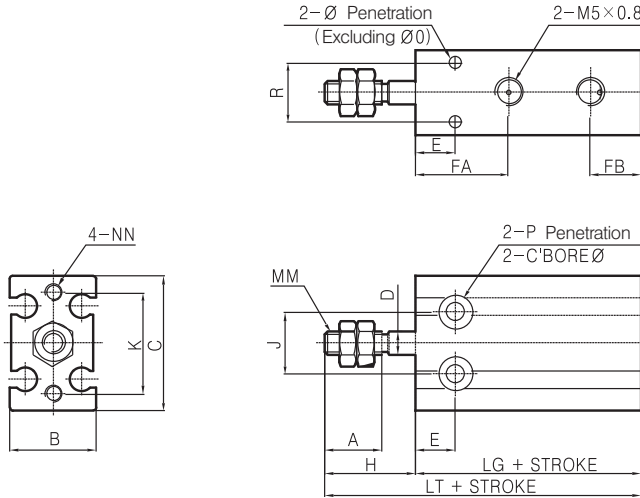

Ø20, Ø25

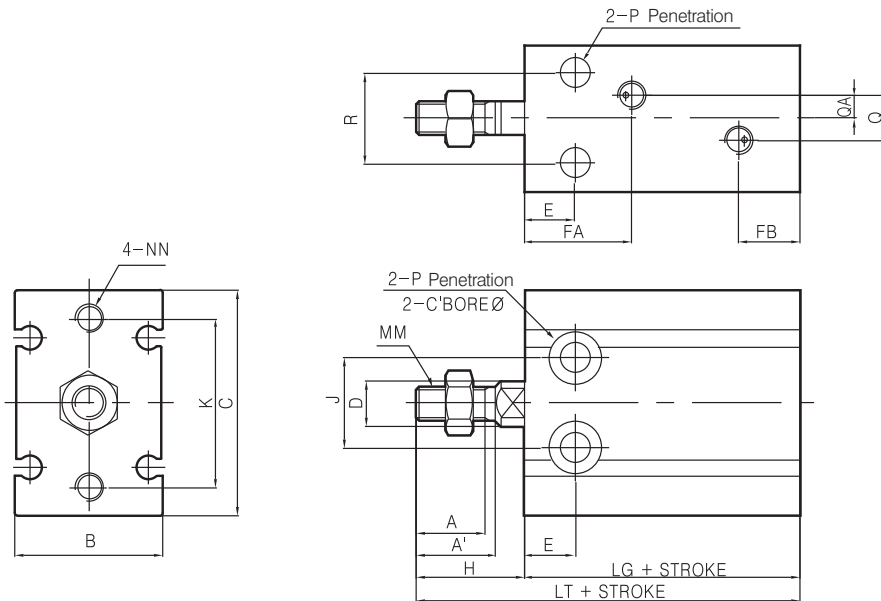

Bore Size (mm)	A	A'	B	C	D	E	FA	FB	H	J	K	MM	NN		P	Q	QA	R	T	Auto Switch Does Not Exist		Auto Switch Exist	
																				LG	LT	LG	LT
10	10	-	15.2	24	4	7	16.5	9	16	11	18	M4×0.7	M3×0.5	DP:5	3.2	-	-	-	6 DP:5	35	51	35	51
16	11	12.5	20	32	6	7	16.5	11	16	14	25	M5×0.8	M4×0.7	DP:6	4.3	-	-	12	7.6 DP:6.5	31	47	40	56
20	12	14	26	40	8	9	19	11	19	16	30	M6×1.0	M5×0.8		5.3	8	4	16	9.3 DP:8	36	55	44	63
25	15.5	18	32	50	10	10	21.5	13	23	20	38	M8×1.25	M5×0.8	DP:8	5.3	9	4.5	20	9.3 DP:9	40	63	48	71

Series **NDMW**

Direct Mount Cylinder/Double Acting Double Rod

Bore Size(mm) : Ø10, Ø16, Ø20, Ø25



- SPACE SAVING COMPACT DESIGN
- MULTIPLE MOUNTINGS
- NON-ROTATING ROD TYPE AVAILABLE
- NON LUBRICATED SERVICE STANDARD

Symbol

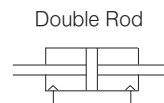

- ACP
- APM
- AS
- AX
- AM2
- AM
- AL
ALX
- AQ
ADQ
- AQ2
ADQ2
- AJ
AJM
- ABK
- ACK1
- NSK
- AG
- NGQ
- AGX
GX
- NP
- ADR
- AMR
- NDM**
- ARD
- NST
- AST
- ASTH
- NLCD
- NLCS

How to Order

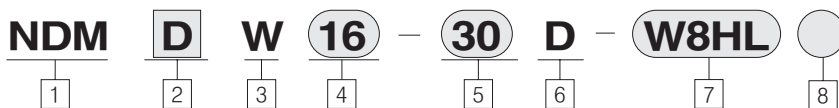

1 Direct Mount Cylinder

2 Blank : Non-Magnet
D : Built-in Magnet

3 Double Rod Type

4 Bore Size(mm)
10 : φ 10
16 : φ 16
20 : φ 20
25 : φ 25

5 Stroke(mm)
φ 10, 16 : 5, 10, 15, 20, 25, 30
φ 20, 25 : 5, 10, 15, 20, 25, 30, 40, 50

6 Action
D : Double Acting

7 Auto Switch

Blank : None
W9H(V) : Solid State Switch
(DC 24V) - 3wire
W8H(V) : Reed Switch
(DC 24V, DC 100V)
※ Standard Auto Switch lead wire length is 1m.
3m leads available on all models by adding a
"L" suffix to the part number.
Example) W1H → W1HL

8 Number of Auto Switches

Blank : 2 pcs
S : 1 pc
N : N pcs

Series NDMW

Standard Specifications

Fluid	Air
Proof pressure	1.05MPa(149psi)
Max. operating pressure	0.7MPa(99psi)
Ambient and fluid temperature	5~60℃
Lubrication	Not required
Cushion	Both Sides RUBBER Cushion
Rod end thread	Male thread
Thread tolerance	KS 2 Class
Stroke allowance	+1.0 0
Mounting	Basic type

Theoretical Force

Bore size (mm)	Rod diameter (mm)	hydraulic area (mm)	Operating pressure (Mpa)		
			0.3	0.5	0.7
ø 10	4	66.0	19.8	33.0	46.2
ø 16	6	172	51.6	86.0	121
ø 20	8	264	79.2	132	185
ø 25	10	412	124	206	288

Construction/Parts List

NDMW ø 10, ø 16

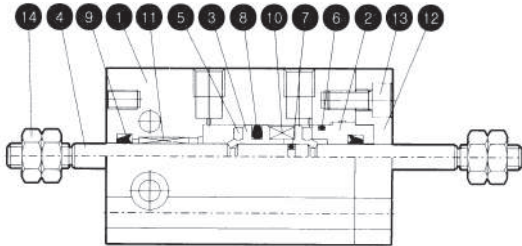

NDMW ø 20, ø 25

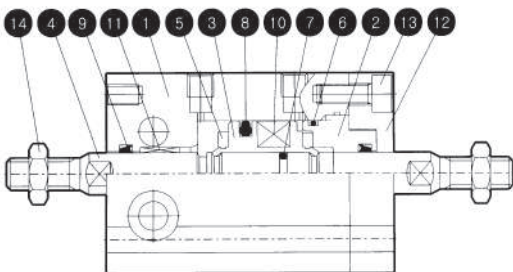

Parts List

No.	Description	Material	Note
1	Cylinder Tube	Aluminum alloy	Hard alumite
2	Rod Cover	Aluminum alloy	Hard alumite
3	Piston	Brass	ø 10
		Aluminum alloy	ø 16~ø 25 Cromate
4	Piston Rod	Stainless steel	
5	Bumper	Urethane	
6	Head Cover Gasket	NBR	
7	Piston Gasket	NBR	
8	Piston Packing	NBR	
9	Rod Packing	NBR	
10	Magnet	-	
11	Bush	Sintered oil bearing alloy	
12	Retainer	Aluminum alloy	Hard Allumite
13	Hexagonal Head Cap Screw	Carbon steel	Nickel plated
14	Rod End Nut	Carbon steel	

Series NDMW

Double Acting/Double Rod Type(NDMW)

Ø10, Ø16

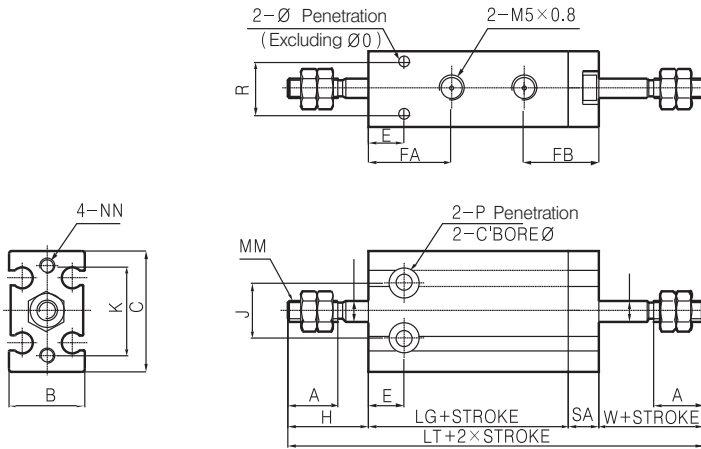

Ø20, Ø25

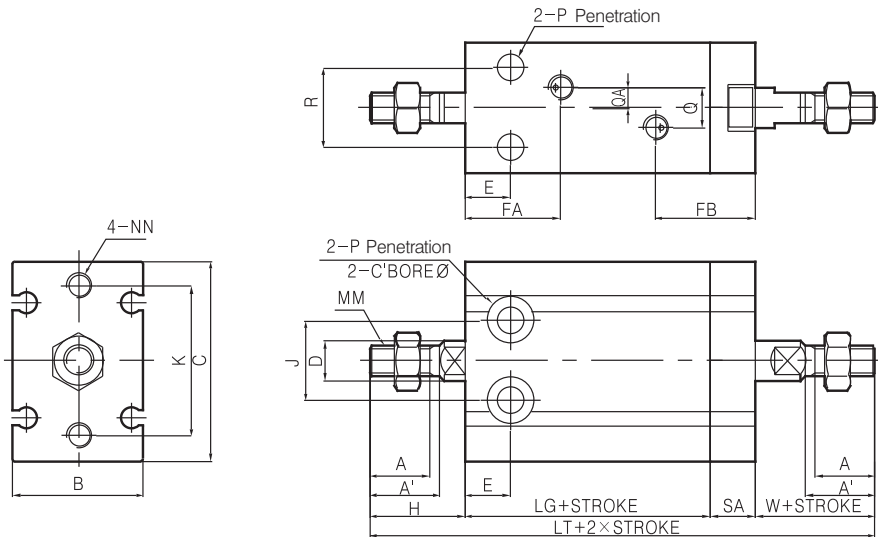

Bore Size (mm)	A	A'	B	C	D	E	FA	FB	H	J	K	MM	NN	P	Q	QA	R	SA	T	W	Auto Switch Does Not Exist		Auto Switch Exist	
																					LG	LT	LG	LT
10	10	-	15.2	24	4	7	16.5	15	16	11	18	M4×0.7	M3×0.5 DP:5	3.2	-	-	-	6	6DP:5	16	35	73	35	73
16	11	12.5	20	32	6	7	16.5	17.5	16	14	25	M5×0.8	M4×0.7 DP:6	4.3	-	-	12	7.5	7.6DP:6.5	16	31	70.5	40	79.5
20	12	14	26	40	8	9	19	20	19	16	30	M6×1.0	M5×0.8	5.3	8	4	16	9	9.3DP:8	19	36	83	44	91
25	15.5	18	32	50	10	10	21.5	20	23	20	38	M8×1.25	M5×0.8 DP:8	5.3	9	4.5	20	9	9.3DP:9	23	40	95	48	103

- ACP
- APM
- AS
- AX
- AM2
- AM
- AL
- ALX
- AQ
- ADQ
- AQ2
- ADQ2
- AJ
- AJM
- ABK
- ACK1
- NSK
- AG
- NGQ
- AGX
- GX
- NP
- ADR
- AMR
- NDM**
- ARD
- NST
- AST
- ASTH
- NLCD
- NLCS

Series **NDMK**

Direct Mount Cylinder/Double Acting/Non-Rotating Rod/Single Rod

Bore Size(mm) : \varnothing 10, \varnothing 16, \varnothing 20, \varnothing 25

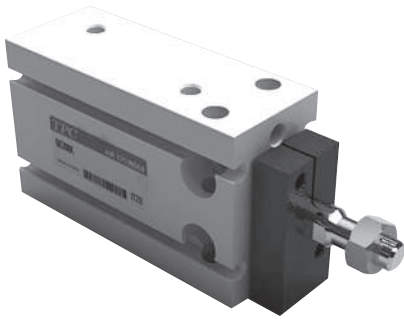

- SUPPORTING LATERAL LOAD WITH LONG BUSH
- A SPACE - SAVING
- EASY MOUNTING AND STRONG HOLD

Symbol

Non-Rotating Rod/Single Rod

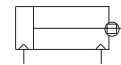

How To Order

NDM D K 10 — 30 D — W8HL S

1 2 3 4 5 6 7 8

- ① Direct Mount Cylinder
- ② Blank : Non-Magnet
D : Built-in Magnet
- ③ Non-Rotating
- ④ Bore Size
10 : \varnothing 10
16 : \varnothing 16
20 : \varnothing 20
25 : \varnothing 25
- ⑤ Stroke (mm)
 \varnothing 10, 16 : 5, 10, 15, 20, 25, 30st
 \varnothing 20, 25 : 5, 10, 15, 20, 25, 30, 40, 50st
- ⑥ Acting
D : Double Acting

- ⑦ Auto Switch
Blank : None
W8H(V) : Reed Switch - 2 wire
(DC24V, AC110V)
W9H(V) : Solid State Switch - 3 wire
(DC24V)
* Standard Auto Switch lead wire length is 1m.
3m leads available on all models by
adding a "L" suffix to the part number.
Example)W1H → W1HL
- ⑧ Number of Auto Switches
Blank : 2 pcs
S : 1 pc

Caution

Be sure to read before handling

Series NDMK

Standard Specifications

Acting	Double acting single rod
Fluid	Air
Proof pressure	1.05MPa(10.5kgf/cm ²)
Max. operating pressure	0.7MPa(7kgf/cm ²)
Min. operating pressure	0.05MPa(0.5kgf/cm ²)
Ambient and fluid temperature	5 ~ 60°C
Lubrication	Not required
Piston Speed	50 ~ 500mm/sec
Cushion	Both Side Rubber Cushion
Rod end thread	Male thread
Thread tolerance	KS 2 class
Stroke allowance	+1.0 0
Mounting	Basic type

Non-Rotating Piston Rod Accuracy/Specification

Bore Size	Ø10, Ø16	Ø20, Ø25
Non-Rotating Piston Rod Accuracy	±0.8°	±0.5°

Construction/Parts List/Non-Rotating Piston Single Rod Type

Ø10, Ø16

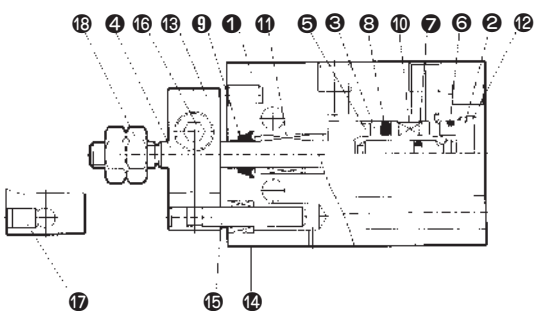

Ø20, Ø25

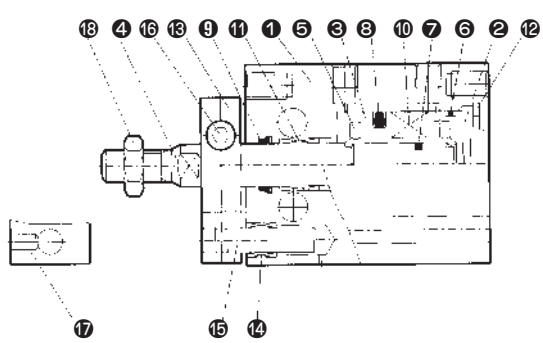

No.	Description	Material	Note
1	Cylinder Tube	Aluminum alloy	Hard alumite
2	Head Cover	Aluminum alloy	Alumite
3	Piston	Brass	Ø6, Ø10
		Aluminum alloy	Ø6~Ø32 Chromate
4	Piston Rod	Stainless steel	
5	Bumper	Urethane rubber	
6	Head Cover Gasket	NBR	
7	Piston Gasket	NBR	
8	Piston Packing	NBR	
9	Rod Packing	NBR	
10	Magnet	-	
11	Bush	Sintered oil bearing alloy	
12	Snap Ring	Spring Steel	Nickel Plated
13	Anti-rotating plate	Aluminum Alloy	Hard alumite
14	Guide Bush	Sintered oil bearing alloy	
15	Guide Rod	Stainless Steel	
16	Hexagonal head Cap screw	Carbon Steel	
17	Hexagon socket	Carbon Steel	
18	Rod End Nut	Carbon Steel	Nickel Plated

- ACP
- APM
- AS
- AX
- AM2
- AM
- AL
- ALX
- AQ
- ADQ
- AQ2
- ADQ2
- AJ
- AJM
- ABK
- ACK1
- NSK
- AG
- NGQ
- AGX
- GX
- NP
- ADR
- AMR
- NDM**
- ARD
- NST
- AST
- ASTH
- NLCD
- NLCS

Series NDMK

Double Acting/Non-Rotating Single Rod

Ø10, Ø16

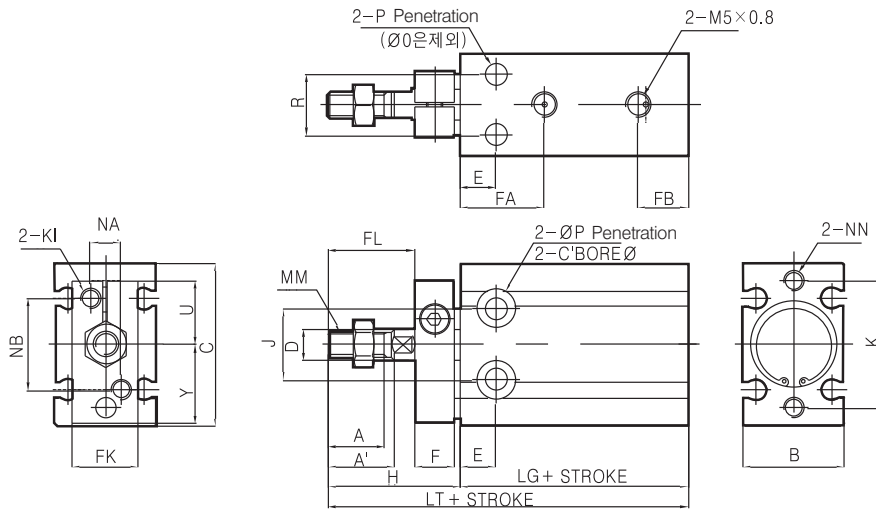

Ø20, Ø25

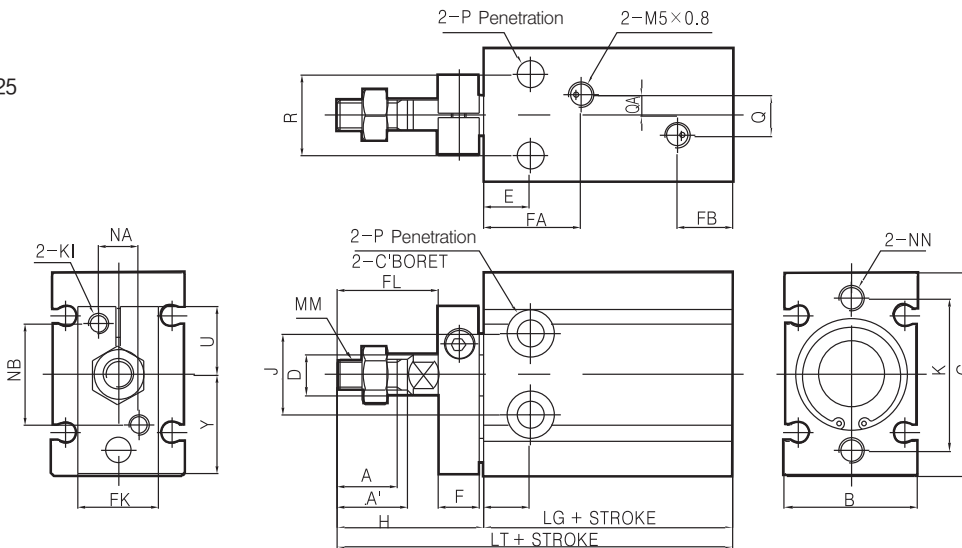

Bore Size (mm)	A	A'	B	C	D	E	F	FL	FK	FA	FB	H	J	K	KI	MM	NA	NB	NN NN	P	Q	QA	R	T T	U	Y	Auto Switch Does Not Exist		Auto Switch Exist	
																									LG	LT	LG	LT		
10	10	-	15.2	24	4	7	8	12	12	16.5	9	21	11	18	M3×0.5	M4×0.7	7	15	M3×0.5 DP-5	3.2	-	-	-	6 DP-5	10.5	11.5	35	56	35	56
16	11	13	20	32	6	7	8	17	13	16.5	10	26	14	25	M3×0.5	M5×0.8	6	18	M4×0.7 DP-6	4.3	-	-	12	7.6 DP-6.5	12.5	15.5	31	57	40	66
20	12	14	26	40	8	9	8	20	16	19	13	29	16	30	M4×0.7	M6×1.0	8	20	M5×0.8	5.3	8	4	16	9.3 DP-8	13.5	19.5	36	65	44	73
25	15.5	18	32	50	10	10	10	22	20	21.5	13	33	20	38	M5×0.8	M8×1.25	10	28	M5×0.8 DP-8	5.3	9	4.5	20	9.3 DP-9	19	24.5	40	73	48	81

Series **NDMKW**

Direct Mount Cylinder/Double Acting/Non-Rotating Piston Double Rod

Bore Size(mm) : Ø10, Ø16, Ø20, Ø25



- SUPPORTING LATERAL LOAD WITH LONG BUSH
- A SPACE - SAVING
- EASY MOUNTING AND STRONG HOLD

Symbol

Non-Rotating Rod/Double Rod

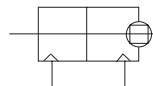

ACP
APM
AS
AX
AM2
AM
AL ALX
AQ ADQ
AQ2 ADQ2
AJ AJM
ABK
ACK1
NSK
AG
NGQ
AGX GX
NP
ADR
AMR
NDM
ARD
NST
AST
ASTH
NLCD
NLCS

How to Order

NDM D KW 10 — 30 D — W8HL S

1
2
3
4
5
6
7
8

- ① Direct Mount Cylinder
- ② Blank : Without Magnet
D : Built-in Magnet
- ③ Non-Rotating Piston Double Rod
- ④ Bore Size
10 : Ø10
16 : Ø16
20 : Ø20
25 : Ø25
- ⑤ Stroke (mm)
Ø10, 16 : 5, 10, 15, 20, 25, 30st
Ø20, 25 : 5, 10, 15, 20, 25, 30, 40, 50st
- ⑥ Acting
D : Double Acting

- ⑦ Auto Switch
Blank : None
W8H(V) : Reed Switch - 2 wire
(DC24V, AC110V)
W9H(V) : Solid State Switch - 3 wire
(DC24V)
* Standard Auto Switch lead wire length is 1m.
3m leads available on all models by
adding a "L" suffix to the part number.
Example)W1H → W1HL

- ⑧ Number of Auto Switches
Blank : 2 pcs
S : 1 pc

Caution

Be sure to read before handling

Series NDMKW

Standard Specification

Non-Rotating Rod Accuracy

Bore Size	φ 10, φ 16	φ 20, φ 25
Non-Rotating Rod Accuracy	±0.8°	±0.5°

Operating Type	Double acting Single Rod
Fluid	Air
Proof Pressure	10.5MPa(149psi)
Max. Operating Pressure	0.7MPa(99psi)
Ambient Normal Fluid Temperature	5 ~ 60℃(41° F~140° F)
Lubricant	None(None-Lube)
Piston Speed	50 ~ 500mm/sec
Cushion	Rubber Cushion
Rod end thread	Male thread
Thread Tolerance	KS class 2
Stroke Tolerance	+1.0 0
Mounting	Basic

Construction / Non-Rotating Piston / Double Rod Type

φ 10, φ 16

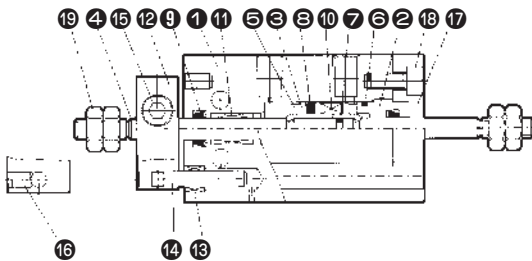

φ 20, φ 25

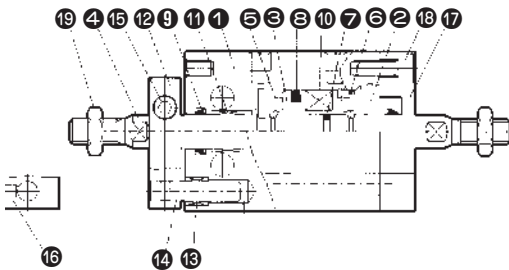

No.	Description	Material	Note
1	Cylinder Tube	Aluminum Alloy	Hard Alumite
2	Head Cover	Aluminum Alloy	Alumite
3	Piston	Brass	φ 6, φ 10
		Aluminum Alloy	φ 16~φ 32Chromate
4	Piston Rod	Stainless Steel	
5	Bumper	Urethane Rubber	
6	Head Cover Gasket	NBR	
7	Piston Gasket	NBR	
8	Piston Packing	NBR	
9	Rod Packing	NBR	
10	Magnet	-	
11	Bush	Sintered Oil Bearing Alloy	
12	Anti-rotating Plate	Aluminum Alloy	Hard Alumite
13	Guide Bush	Sintered Oil Bearing Alloy	
14	Guide Rod	Stainless Steel	
15	Hexagonal Head Cap Screw	Carbon Steel	
16	Hexagon Socket	Carbon Steel	
17	Retainer	Aluminum alloy	Hard Alumite
18	Hexagonal Head Cap Screw	Carbon Steel	
19	Rod End Nut	Carbon Steel	Nickel Plated

Series NDMKW

Double Acting/Non-Rotating Piston Double Rod

Ø10, Ø16

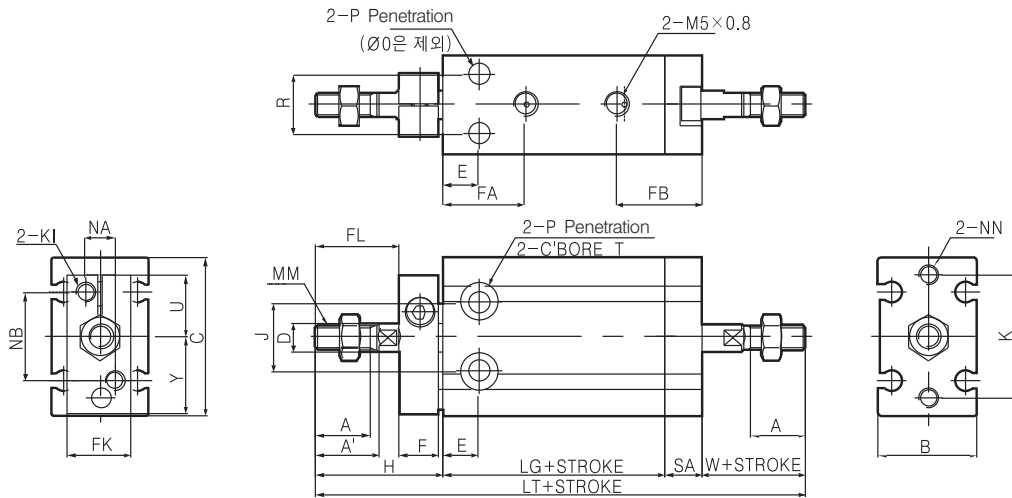

Ø20, Ø25

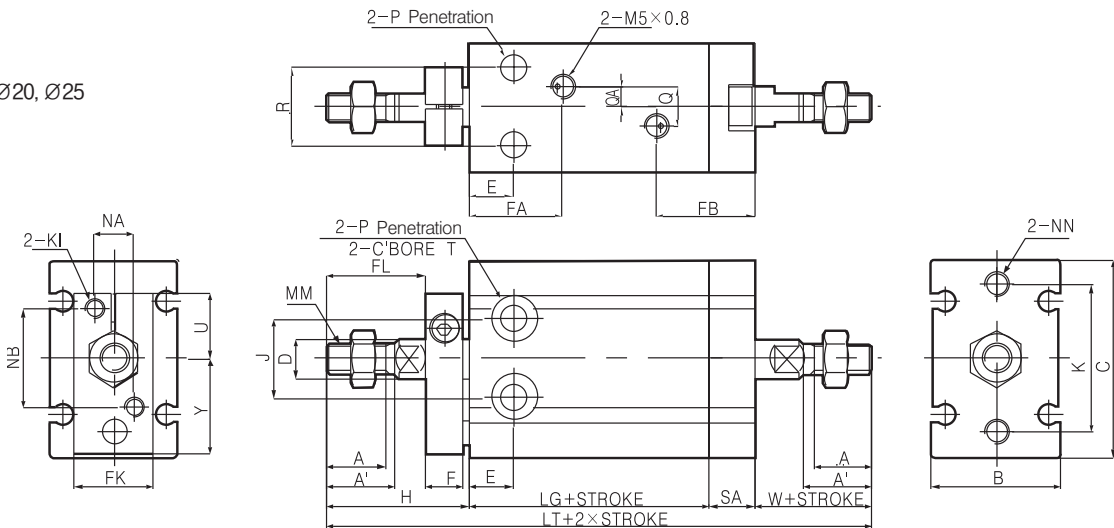

Bore Size (mm)	A	A'	B	C	D	E	F	FL	FK	FA	FB	H	J	K	KI	MM	NA	NB	NN	P	Q	QA	R	SA	T	U	Y	Auto Switch Does Not Exist		Auto Switch Exist	
																												LG	LT	LG	LT
10	10	-	15.2	24	4	7	8	12	12	16.5	15	21	11	18	M3x0.5	M4x0.7	7	15	M3x0.5 DP-5	3.2	-	-	-	6	6DP-5	10.5	11.5	35	78	35	78
16	11	13	20	32	6	7	8	17	13	16.5	17.5	26	14	25	M3x0.5	M5x0.8	6	18	M4x0.7 DP-6	4.3	-	-	12	7.5	7.6DP-6.5	12.5	15.5	31	80.5	40	89.5
20	12	14	26	40	8	9	8	20	16	19	20	29	16	30	M4x0.7	M6x1.0	8	20	M5x0.8	5.3	8	4	16	9	8.3DP-8	13.5	19.5	36	93	44	101
25	15.5	18	32	50	10	10	10	22	20	21.5	22	33	20	38	M5x0.8	M8x1.25	10	28	M5x0.8 DP-8	5.3	8	4	20	9	8.3DP-9	19	24.5	40	105	48	113

- ACP
- APM
- AS
- AX
- AM2
- AM
- AL
- ALX
- AQ
- ADQ
- AQ2
- ADQ2
- AJ
- AJM
- ABK
- ACK1
- NSK
- AG
- NGQ
- AGX
- GX
- NP
- ADR
- AMR
- NDM**
- ARD
- NST
- AST
- ASTH
- NLCD
- NLCS

Series NDMKW

Checking Auto Switch

- A. How to check : After assembling auto switch, check the working of auto switch moving piston
- B. Conditions : W8(plug point) / W9(Non plug point)–Horizontal / Vertical switch
- C. Mounting position : Refer to the drawing
- D. Tolerance : 30%
- E. Setting postion

Unit : mm

Cylinder	Symbol	Position of Auto Switch			
		Ø10	Ø16	Ø20	Ø25
NDMD	AO	17.0	18.0	20.0	24.0
	BO	2.0	6.0	7.0	8.0

