

# Series **AST**

## Stopper Cylinder

Bore Size(mm) : Ø50, Ø63, Ø80



DIRECT TYPE



ROLLER TYPE

- IT IS POSSIBLE TO CHANGE THE ROTATION OF THE ACTUATOR BY 360 DEGREES WITH STEPS OF 90°
- AUTO SWITCH CAPABLE
- SINGLE ACTION, DOUBLE ACTION, DOUBLE ACTION WITH SPRING EXTEND AVAILABLE

### Symbol

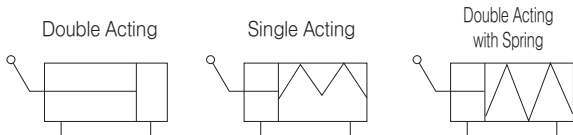

### How to Order

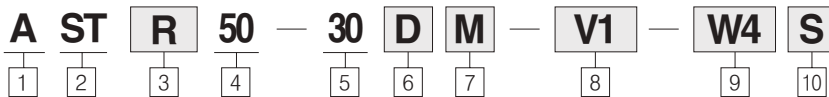

1 Actuator

2 Stopper Cylinder

3 Model Type

Roller : R  
Direct : D

4 Bore Type

50 : 50mm  
63 : 63mm  
80 : 80mm

5 Stroke

φ 50 : 30  
φ 63 : 40  
φ 80 : 40

6 Action

Blank : Single Acting  
D : Double Acting  
Z : Double Acting with Spring

7 Roller

Blank : MC Nylon  
M : Rolled steel(SPA material)

8 Valve

Blank : None  
V1 : AC 110V  
V2 : AC 220V  
V5 : DC 24V

9 Auto Switch

Blank : None  
W : Reed Auto Switch  
W8H/W8V : Reed auto switch  
(horizontal type / vertical type)  
W9H/W9V : Solid State auto switch  
(horizontal Type / vertical Type)

Caution :

1. According to the lead line direction of the existing plug point or non plug point auto switch, it is separated into horizontal/vertical types.
2. When the lead line length is 3m add an L to the end number of the product.  
ex) W8H: W8HL
3. W4, W8H(V):Multiple use of DC24V, AC110V / Multiple use of W9H(V):DC24V

10 Number of Auto Switches

Blank : 2 pcs  
S : 1 pc

ACP
APM
AS
AX
AM2
AM
AL ALX
AQ ADQ
AQ2 ADQ2
AJ AJM
ABK
ACK1
NSK
AG
NGQ
AGX GX
NP
ADR
AMR
NDM
ARD
NST
<b>AST</b>
ASTH
NLCD
NLCS

# Series AST



DIRECT TYPE



ROLLER TYPE

Specifications	
Action	Double Acting, Single Acting, Double Acting with Spring
Fluid	Air
Proof pressure	1.5MPa(213psi)
Max. Operating Pressure	1MPa(142psi)
Min. Operating Pressure	Double Acting:0.1MPa
	Single Acting:0.1MPa
Ambient and Fluid Temperature	-5℃ ~ 70℃
Lubrication	Not Required
Cushion	Rubber Cushion
Stroke Length Tolerance	$\begin{matrix} +1.4 \\ 0 \end{matrix}$
Mounting type	Thru hole (standard), Both ends tapped
Auto Switch	Attachable
Type	Roller Type, Direct Type

Standard Stroke	
Bore Size	Standard Stroke(mm)
φ 50	30
φ 63, φ 80	40

Rod High Rigid	
Tube Bore Size(mm)	ROD Size(mm)
φ 50	32
φ 63	40
φ 80	50

Traverse Load and Operating Pressure							
Bore Size((mm)	Pressure(kgf/cm <sup>2</sup> )						
	1.2	2	3	4	5	6	7
φ 50	5	30	40	70	95	120	150
φ 63	15	40	75	120	150	180	225
φ 80	20	60	110	160	200	240	280

Weight <span style="float: right;">(unit : kgf)</span>		
Bore Size	Type	
	Roller Type	Direct Type
50-30st	2,170	2,200
63-40st	3,584	3,704
80-40st	5,656	5,792

# Series AST

## Stopper Cylinder Selection Process

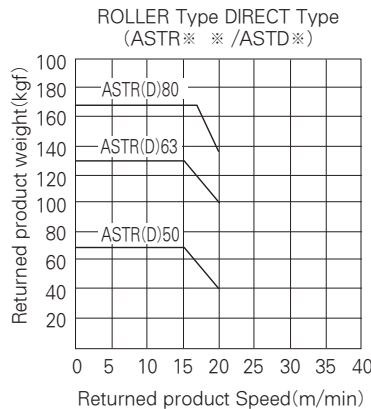
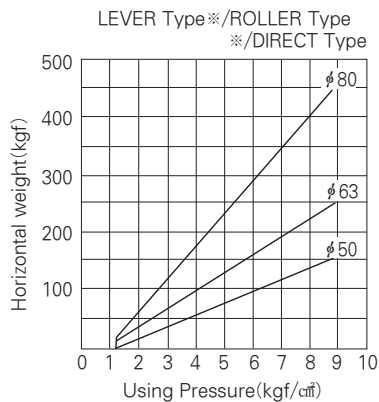

### ⚠ Precautions

Please be fully aware before using Please read the notice(Page 36) for safety.

### Selection

#### ⚠ Caution

- Do not scratch the connection area of piston. piston rod is not hardened, so damage can occur if connection part of pallet is sharp. In case of this, do not use. It causes non-function.
- When stopping temporarily load it is be absorbed to cylinder in Stopper cylinder.

### Mounting

- Do not give the rotation torque to cylinder rod. Contact area of cylinder should be parallel to contact area of pallet in order not to occur rotation torque on the cylinder rod.

### Operation

- Do not use the oil at the connection area of piston rod. Oil causes non-function.

### Repair and maintance

- When changing the direction for preventing rotation, release the two pieces of fixing bolt on the tube cover and rod cover and change the position and then tighten the bolts again.

ACP

APM

AS

AX

AM2

AM

AL  
ALX

AQ  
ADQ

AQ2  
ADQ2

AJ  
AJM

ABK

ACK1

NSK

AG

NGQ

AGX  
GX

NP

ADR

AMR

NDM

ARD

NST

**AST**

ASTH

NLCD

NLCS

# Series AST

## Construction / Parts List

φ 50(Double Acting: ※D)

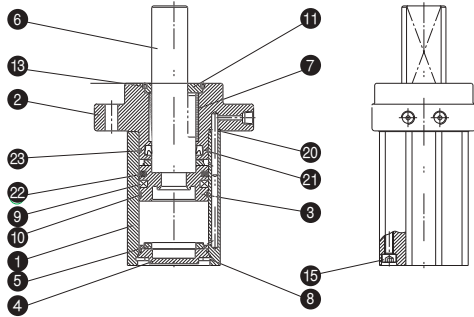

φ 63, φ 80(Double Acting: ※D)

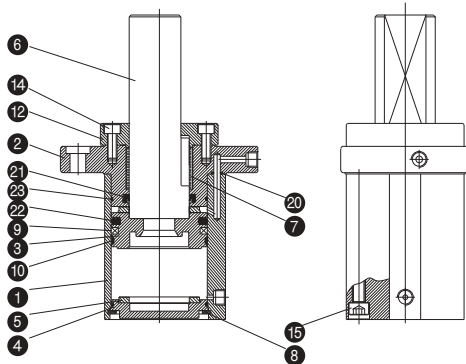

- Single Acting: ※T
  - Double Acting: ※Z
  - V/V Type: ※Z-V※
- Built-in Spring

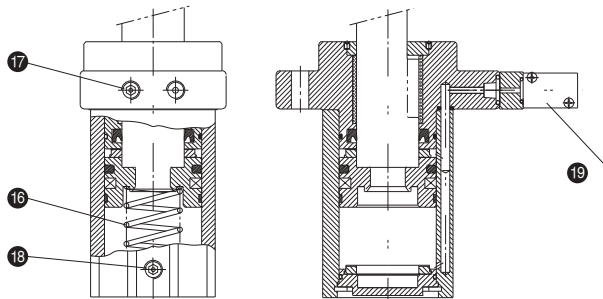

### Parts List

NO.	Description	Material	Qty	Note
1	Tube	Aluminum alloy	1	Hard Alumite
2	Rod Cover	Aluminum alloy	1	
3	Piston	Aluminum alloy	1	Chromate
4	Head Cover	Aluminum alloy	1	White Alumite
5	Bumper	Urethane	2	HEAD, ROD
6	Piston Rod	Carbon Steel	1	Hard Chrome Plated
7	Bush	Lead bronze	1	
8	C Snap ring	Spring Steel	1	
9	Magnet Ring	NBR	1	
10	Wear ring	Resin	1	
11	Guide		1	
12	Cover	Aluminum alloy	1	
13	Bolt	Alloy Steel	1	
14	Bolt	Chrome-molybdenum Steel	4	
15	Bolt	Chrome-molybdenum Steel	4	
16	Return Spring	Spring Steel	1	
17	Plug bolt	Alloy Steel	1	For single Acting φ 50
18	Plug bolt	Alloy Steel	1	For single Acting φ 63, 80
19	Solenoid V/V	—	1	DS2000 Series

### Packing List

NO.	Description	Material	Qty	Bore Size			Note
				φ 50	φ 63	φ 80	
20	O-ring	NBR	2	P5	P5	P6	
21	Rod Packing	NBR	1	PNY-32	PNY-40	PNY-50	
22	Piston Packing	NBR	1	PSD-50	PSD-63	PSD-80	
23	Gasket	NBR	2	C-46	C-60	C-75	ROD, HEAD

# Series AST

## Dimensions / Direct Type

ASTD50-30D

(Unit: mm)

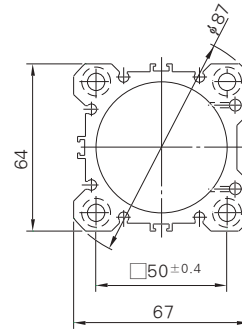
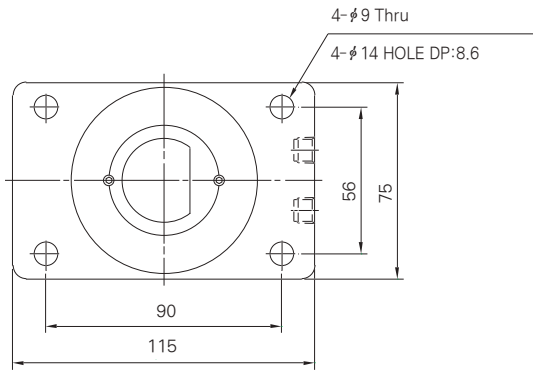

Tube Cutting

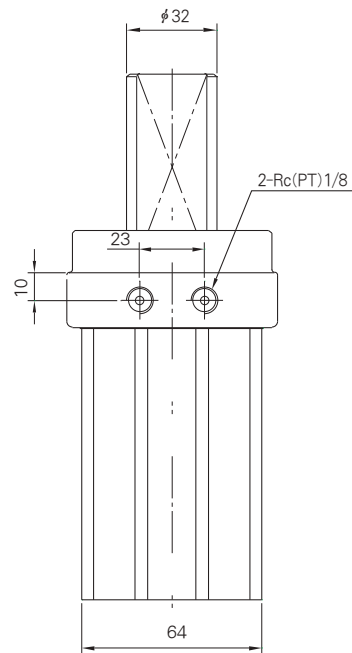
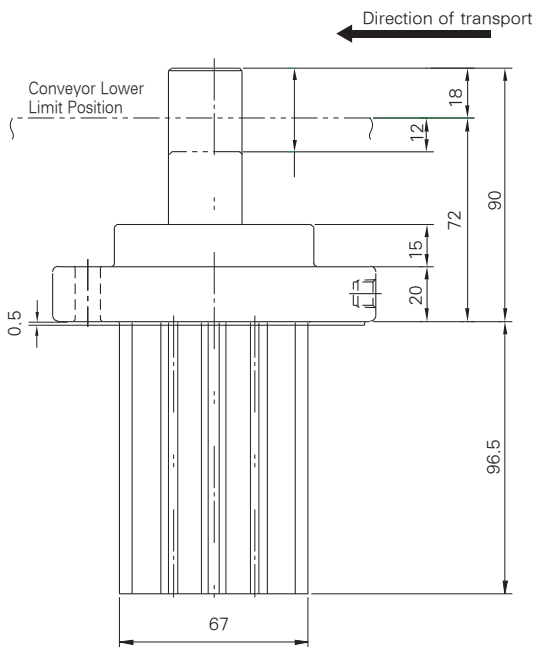

- ACP
- APM
- AS
- AX
- AM2
- AM
- AL
- ALX
- AQ
- ADQ
- AQ2
- ADQ2
- AJ
- AJM
- ABK
- ACK1
- NSK
- AG
- NGQ
- AGX
- GX
- NP
- ADR
- AMR
- NDM
- ARD
- NST
- AST**
- ASTH
- NLCD
- NLCS

# Series AST

## Dimensions / Direct Type

ASTD63-40D

(Unit:mm)

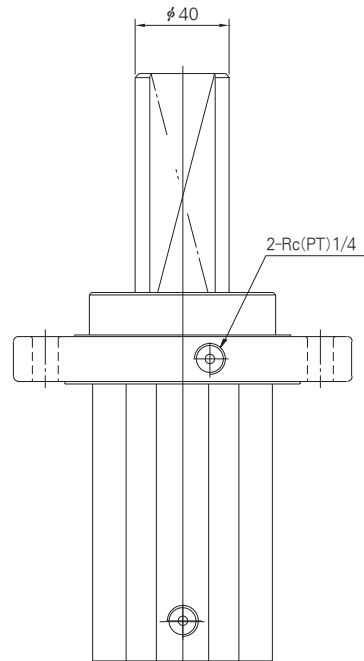
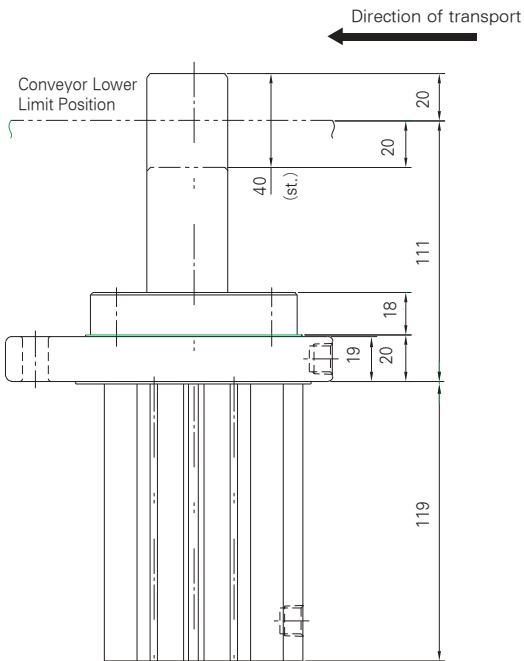
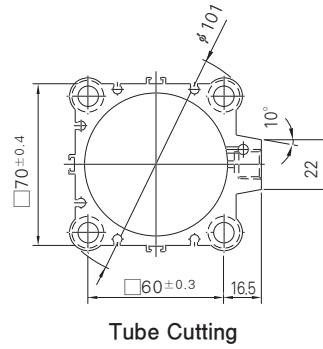
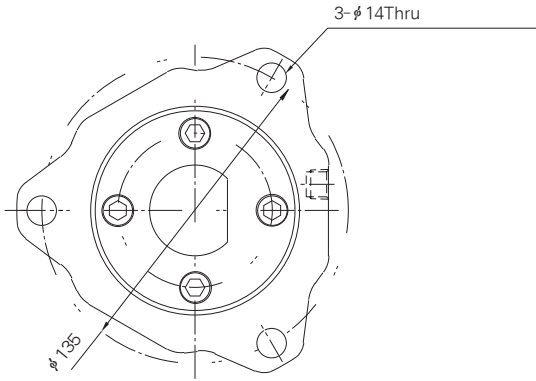

# Series AST

## Dimensions / Direct Type

ASTD80-40D

(Unit:mm)

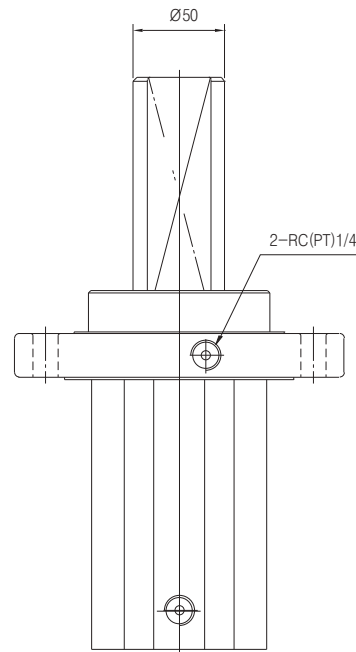
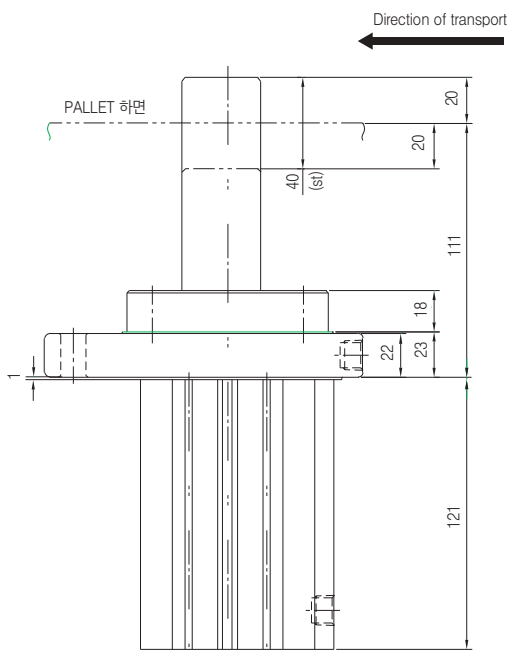
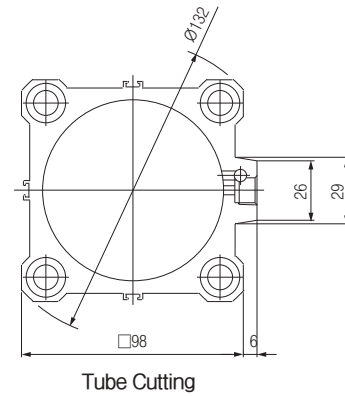
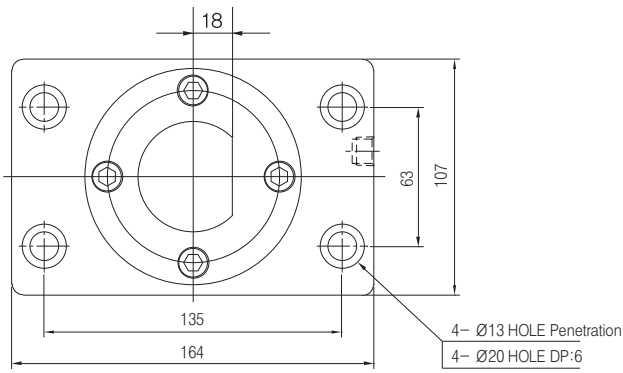

ACP

APM

AS

AX

AM2

AM

AL  
ALX

AQ  
ADQ

AQ2  
ADQ2

AJ  
AJM

ABK

ACK1

NSK

AG

NGQ

AGX  
GX

NP

ADR

AMR

NDM

ARD

NST

**AST**

ASTH

NLCD

NLCS

# Series AST

## Dimensions / Direct Type

φ 50(Double Acting: ※D)

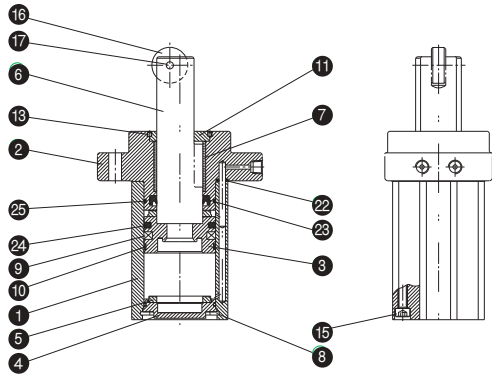

φ 63, φ 80(Double Acting: ※D)

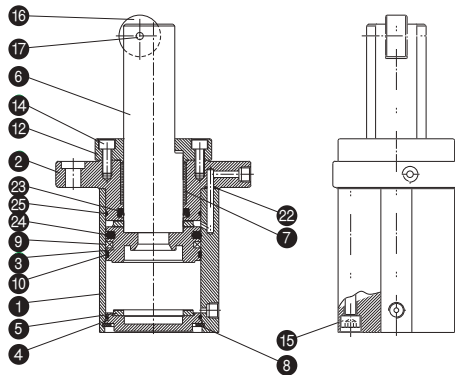

- Single Acting: ※T
  - Double Acting: ※Z
  - V/V Type: ※Z-V※
- Built-in spring

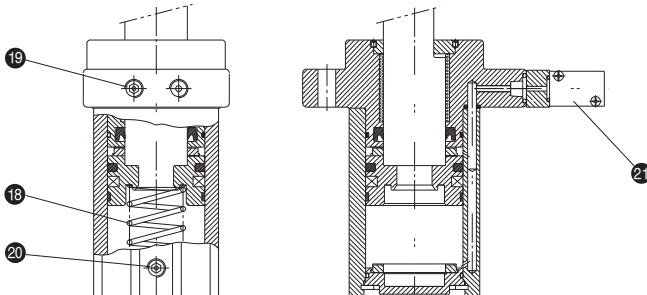

### Parts List

NO.	Description	Material	Qty	Note
1	Tube	Aluminum alloy	1	Hard Alumite
2	Rod Cover	Aluminum alloy	1	
3	Piston	Aluminum alloy	1	Chromate
4	Head Cover	Aluminum alloy	1	White Alumite
5	Bumper	Urethane	2	Head, Rod
6	Piston Rod	Carbon steel	1	Hard Chrome Plated
7	Bush	Lead bronze	1	
8	C SNAPRING	Spring steel	1	
9	Magnet Ring	NBR	1	
10	Wear ring	Resin	1	
11	Guide		1	
12	Cover	Aluminum alloy	1	
13	Bolt	Alloy steel	4	
14	Bolt	Chrome-molybdenum steel	4	
15	Bolt	Chrome-molybdenum steel	1	
16	Roller	(MC-NYLON)	1	
17	Spring pin	Spring steel	1	
18	Return Spring	Spring steel	1	
19	plug bolt	Alloy steel	1	For single Acting φ50
20	plug bolt	Alloy steel	1	For single Acting φ63, 80
21	Solenoid V/V	-	1	DS2000 Series

### Packing List

NO.	Description	Material	Qty	Bore Size(mm)			Note.
				φ 50	φ 63	φ 80	
22	O-ring	NBR	2	P5	P5	P6	
23	Rod Packing	NBR	1	PNY-32	PNY-40	PNY-50	
24	Piston Packing	NBR	1	PSD-50	PSD-63	PSD-80	
25	Gasket	NBR	2	C-46	C-60	C-75C	ROD, HEAD



# Series AST

## Dimensions / Roller Type

ASTR50-30D

(Unit: mm)

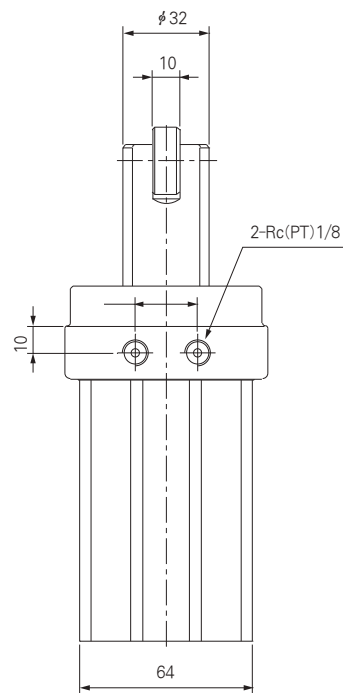
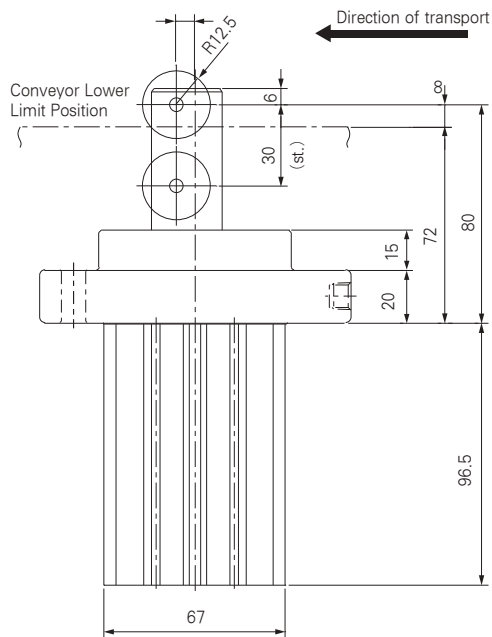
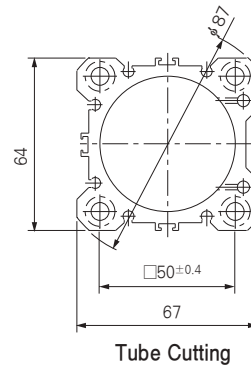
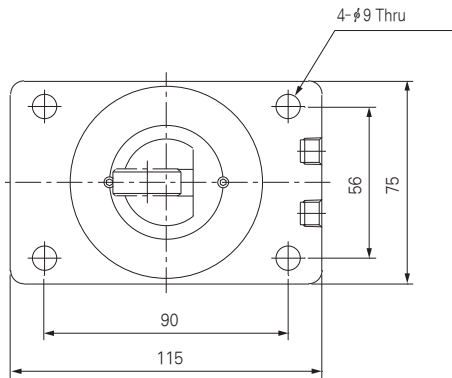

- ACP
- APM
- AS
- AX
- AM2
- AM
- AL
- ALX
- AQ
- ADQ
- AQ2
- ADQ2
- AJ
- AJM
- ABK
- ACK1
- NSK
- AG
- NGQ
- AGX
- GX
- NP
- ADR
- AMR
- NDM
- ARD
- NST
- AST**
- ASTH
- NLCD
- NLCS

# Series AST

## Dimensions / Roller Type

ASTR63-40D

(Unit: mm)

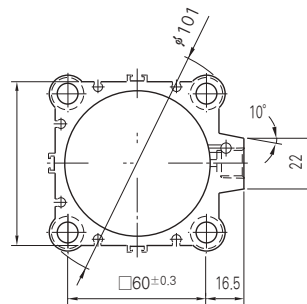
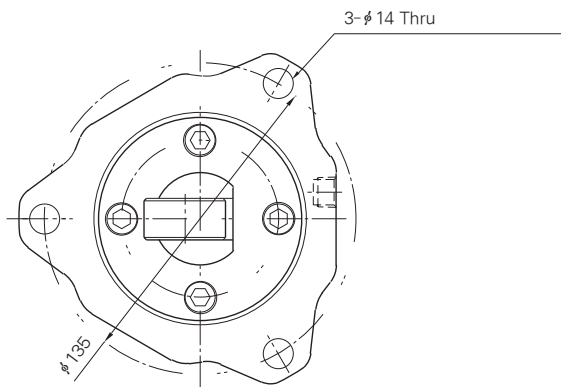

Tube Cutting

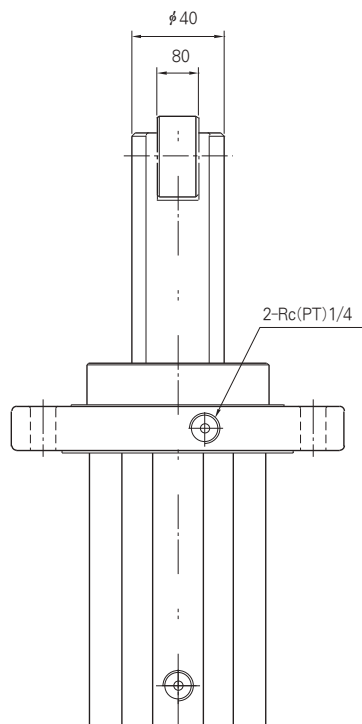
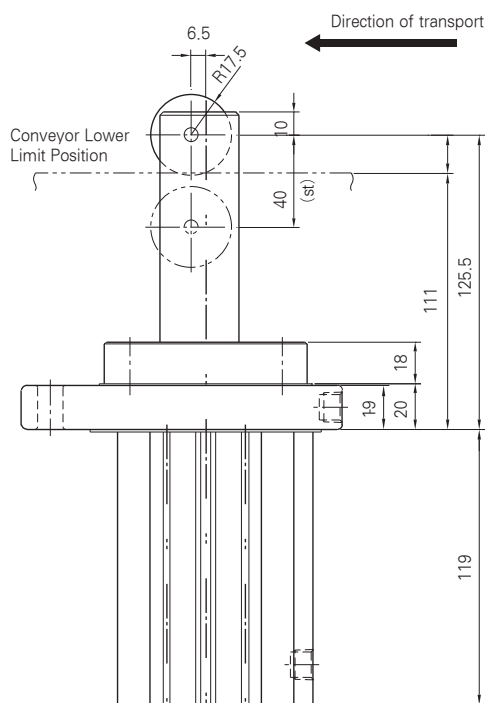

# Series AST

## Dimensions / Roller Type

ASTR80-40D

(Unit: mm)

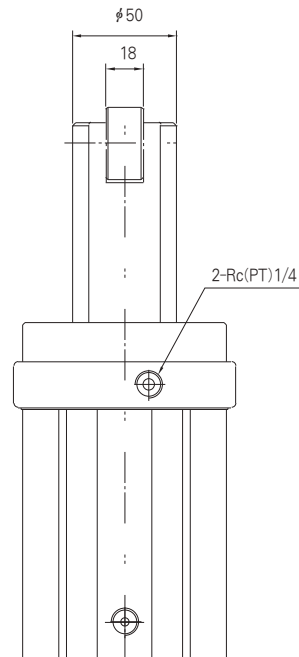
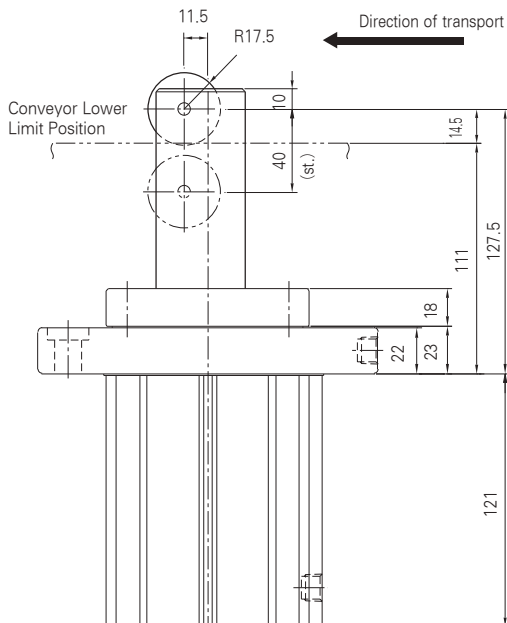
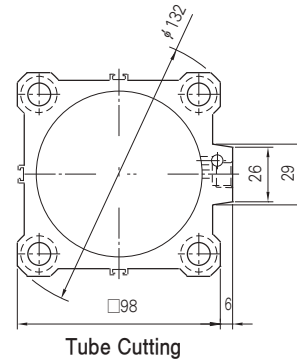
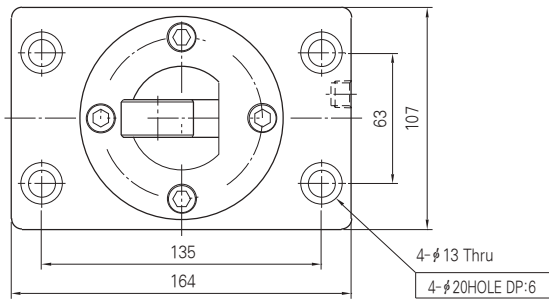

- ACP
- APM
- AS
- AX
- AM2
- AM
- AL
- ALX
- AQ
- ADQ
- AQ2
- ADQ2
- AJ
- AJM
- ABK
- ACK1
- NSK
- AG
- NGQ
- AGX
- GX
- NP
- ADR
- AMR
- NDM
- ARD
- NST
- AST**
- ASTH
- NLCD
- NLCS

## Series AST

### Auto Switch



- Leakage current - None
  - Response time - 1.2ms
  - Lead Wire - Oil proof vinyl.  $\phi 3.4$ , 0.2mm<sup>2</sup>, 2 wire (red, black), 0.5m
  - Impact Resistance - 30G
  - Insulation Resistance - 50M $\Omega$  or more under the test voltage DC500V (Between case and cable)
  - Withstand Voltage - 1500VAC 1min (between case and cable)
  - Ambient Temperature - 5~60 $^{\circ}$ C
  - Protection Structure - IEC spec IP67, Water-proof (JISCO920), oil-proof,
- ※ If 3m lead wire is required, L is put at end of model numbers.  
(Example)W4L

### Auto Switch Specifications

#### W4 (With Indicator Lamp)

Auto Switch Model	W4	
Application	Relay, Sequence Control	
Voltage	DC24V	AC110V
Range of Load Current	5~40mA	5~20mA
Protection Circuit for Contact Breaker point	None	
Internal Voltage Drop	2.4V or less	
Indicator Lamp	ON: Red light emitting diode	

### Auto Switch/Internal Circuit

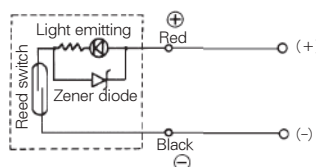

### Auto Switch Dimensions

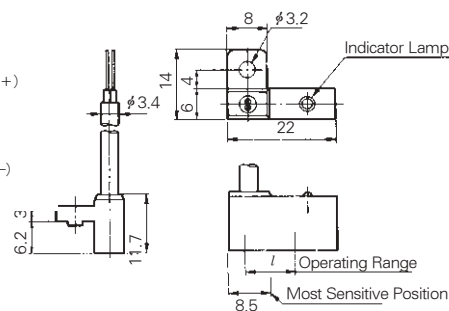

## ! Precautions

### Selection

1. When the lever is in a standing up position do not allow it to collide with the pallet.
  - When the lever is standing up and it collides with the pallet, power is absorbed to the cylinder body, so make sure no collision occurs.
2. Within the limits of the speed and weight of the product on the cat, only use when stopping the pallet.
  - When stopping the stopper cylinder from the connected cat, the cylinder driving force becomes horizontally lowered; if this occurs, please contact us.

### Mounting

1. Make sure the rotation torque does not get tangled in the cylinder rod.
  - To make sure the rotation torque does not get tangled in the cylinder rod, mount it so that the cylinder rod contact area is parallel to the pallet contact area.
2. Be careful that the piston rod side-way does not become damaged.
  - Packing damages may be the reason for operational errors and air leakages.

### Operation

1. When attaching a lever type lock device, after lever locking, make sure outside force from the opposite direction does not get tangled.
  - When moving the conveyor or pallet, make sure to backup and pull down the cylinder.
2. When activating the pull up and pull down function of the cylinder, be careful of the narrow crack between the lever holder and the rod flange.
  - Make sure your hands or other instruments accidentally do not slip into the crack while operating.
3. Be careful that no cutting & grinding oil, water or dust wells up.
  - It will bring about damage to the shock-absorber.
4. Adjust the rod of the shock-absorber to its maximum level to collide with the returned product.
  - When the returned product energy is larger than the shock-absorber suction force during a collision, the lever holder will absorb the load.  
(When output is in the maximum force stage)