

Series AQ2, ADQ2

Compact Cylinder (a Square tube)/Double Acting, Single Rod Type

Bore Size(mm) : Ø12, Ø16, Ø20, Ø25, Ø32, Ø40, Ø50, Ø63, Ø80, Ø100, Ø125, Ø140 (refer to p.340)



- SPACE SAVING CYLINDER
- COMPACT EQUIPMENT DESIGN AVAILABLE
- SMALL AUTO SWITCH EQUIPPED IN SQUARE TUBE

Symbol

Double Acting : Single Rod Type

Rear Boss Mount

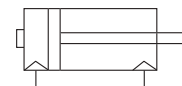
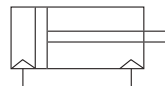

How to Order

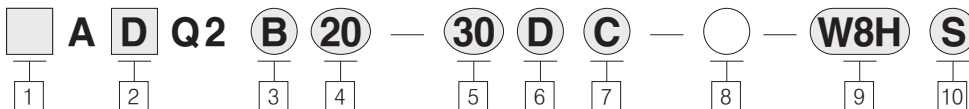

1 Magnet

Blank : Rc(PT)
U : NPT

2 Magnet

Blank : None
D : Built-in Magnet

3 Attaching Type

B : Through hole (standard type)
A : Both end tapped
D : Double rear clevis (standard both end tapped)
F : Rod side flange (standard both end tapped)
G : Head side flange (standard both end tapped)
L : Foot (standard both end tapped)
* Mountings are delivered without assembly
* D, F, L 25φ or less cannot be attached

4 Bore Size

12 : 12mm(1/2Nom.)	40 : 40mm(1 1/2Nom.)
16 : 16mm(5/8Nom.)	50 : 50mm(2Nom.)
20 : 20mm(3/4Nom.)	63 : 63mm(2 1/2Nom.)
25 : 25mm(1Nom.)	80 : 80mm(3 1/4Nom.)
32 : 32mm(1 1/4Nom.)	100 : 100mm(4Nom.)

5 Stroke(mm)

12,16 : 5,10,15,20,25,30
20,25 : 5,10,15,20,25,30,35,40,45,50
32,40 : 5, 10, 15, 20, 25, 30, 35, 40, 45, 50, 75, 100
50-100 : 10,15,20,25,30,35,40,45,50,75,100

6 Action

D : Double Acting Type

7 Body Specification

Blank : Standard type
(rod end female thread)

C : Rubber Cushion Attached

M : Rod end male thread

F : Rear boss mount

I : Single knuckle joint (rod end male thread)

Y : Double Knuckle Joint (rod end male thread)

* Possible to combine body specification (CM, CF, CI, CF, CFI, CFY, etc.)

* F is not available for φ 12, φ 16

* I and Y are delivered without assembly

8 Special Option

Blank : Standard type

XC16 : Copper-free

* Ø12~Ø40 : XC16 is standard type

9 Auto Switch

Blank : None

Reed switch

W4 : W4 (Ø32~Ø100)

W8H(V) : Compact auto switch

horizontal (vertical) type, 2 wire type

Non contact point existing auto switch

W9H(V) : Compact auto switch

horizontal (vertical) type, 2 wire type

W9H(VN) : Compact auto switch

horizontal (vertical) type, 3 wire type

W2PL : Ø50~Ø100

* In case of 3m lead wire, L should be added at the end of item number

ex) W4L or W2PL

* In case of 5m lead wire, please contact us

10 Number of Auto Switches

Blank : 2 pcs

S : 1 pc

N : N pcs

Item Number of Mounting

Bore Size (mm)	Foot	Flange	Double Clevis
	I-Knuckle	Y-Knuckle	Joint Pin
12	AQL-012	AQF-012	AQD-012
	QI-012	QY-012	QP-012
16	AQL-016	AQF-016	AQD-016
	QI-016	QY-016	QP-012
20	AQL-020	AQF-020	AQD-020
	QI-020	QY-020	QP-020
25	AQL-025	AQF-025	AQD-025
	QI-025	QY-025	QP-025
32	QL-032	QF-032	QD-032
	QI-032	QY-032	QP-032
40	QL-040	QF-040	QD-040
	QI-032	QY-032	QP-032
50	QL-050	QF-050	QD-050
	QI-050	QY-050	QP-050
63	QL-063	QF-063	QD-063
	QI-050	QY-050	QP-050
80	QL-080	QF-080	QD-080
	QI-080	QY-080	QP-080
100	QL-0100	QF-100	QD-100
	QI-0100	QY-100	QP-100

* In case of ordering foot mountings, please order 2EA foot mountings per 1EA cylinder

● Notice

* Production of middle stroke

Minimum 3mm to 1mm middle stroke production is available by means of mountings spacer at standard stroke cylinder.

ex) AQ2B32-27D inserts 3mm wide spacer in standard cylinder AQ2B32-30D

ex) AQ2B32-29D inserts 21mm wide spacer in standard cylinder AQ2B32-50D

Series AQ2, ADQ2

Notices for products

Please fully understand the notices prior to utilization, and refer to safety notice and common notice.

Warning

Assembly/Disassembly of Snap Ring

- Please use proper flyer (Attached tool of C-type snap ring) for assembly / disassembly.
- Please be cautious all the time that there is possible damage to human body or nearby equipments owing to projection of snap ring at the end of flyer (C-type snap ring) in spite of using proper flyer (Attached tool of C-type snap ring). Moreover, after checking full connection of snap ring during attachment, supply air.

Mounting

- Loading removing should be carried out with fixing load side piston rod 2 face width part.
- If load-side piston rod is not firmly fixed, connecting part (screw fixing part) of piston rod is possibly released.

Options

Bore Size(mm)		12	16	20	25	32	40	50	63	80	100	
Air	Attachment	Through-hole	○	○	○	○	○	○	○	○	○	
		Both ends Tap	○	○	○	○	○	○	○	○	○	
Pressure Type	Built in Magnet	○	○	○	○	○	○	○	○	○	○	
	Piping Method	M5×0.8					M5×0.8 ^{mm} Rc(PT)1/8	Rc(PT)1/8	Rc(PT)1/4	Rc(PT)3/8		
	Thread Type											
	Rod end Male Thread	○	○	○	○	○	○	○	○	○	○	
	Rubber Cushion Mount	○	○	○	○	○	○	○	○	○	○	
	Rear Boss Mount	-	-	○	○	○	○	○	○	○	○	

(Note 1) When requiring style without auto switch, M5×0.8 for 5mm stroke only.

Specifications

Description	Air Pressure (non-lubrication) Type
Fluid	Air
Guaranteed Pressure Resistance	1.5MPa{15.3kgf/cm ² }
Maximum Pressure Applied	1.0MPa{9.9kgf/cm ² }
Ambient and Applied Fluid Temperature	-5°C~70°C (No Frozen)
Rod end Thread Tolerance	KS Class 2
Stroke Tolerance	+1.0 0
Piston Speed	50~500mm/s
Rubber Cushion	None
Rod end Thread	Female Thread
Mount	Through Hole

Minimum Operation Pressure (Unit : MPa)

Bore Size(mm)	12	16	20	25	32	40	50	63	80	100
Air Pressure (non-lubrication) Type	0.07	0.07	0.05	0.05	0.05	0.05	0.05	0.05	0.05	0.05

Weight Table (Unit : g)

Bore Size (mm)	Cylinder Stroke (mm)											
	5	10	15	20	25	30	35	40	45	50	75	100
12	40	47	54	61	68	75	-	-	-	-	-	-
16	61	72	83	94	105	116	-	-	-	-	-	-
20	91	112	132	152	173	193	213	234	254	274	-	-
25	118	139	160	181	203	224	245	266	287	309	-	-
32	157	180	202	225	248	270	292	316	339	362	522	636
40	272	294	316	338	360	382	404	426	448	470	623	733
50	-	401	439	476	514	551	589	626	663	701	958	1,102
63	-	647	687	727	767	807	847	887	927	967	1,257	1,464
80	-	1,443	1,534	1,624	1,714	1,804	1,894	1,985	2,076	2,166	2,830	3,296
100	-	2,208	2,314	2,420	2,526	2,632	2,738	2,844	2,950	3,056	3,801	4,318

* Refer to p.327 for long stroke series

Option Weights (Unit : g)

Bore Size(mm)	12	16	20	25	32	40	50	63	80	100
Attachment Both End Tap Type	1	2	6	7	7	6	7	17	31	43
Rod End Male Thread Part	1.5	3	6	12	26	27	53	53	120	175
Male Thread Nut	1	2	4	8	17	17	32	32	49	116
Rear Boss Mount	0.7	1.3	2	3	5	7	13	25	45	96
Rubber Cushion Attached	1	2	5	4	-3	-7	-9	-18	-31	-56

Calculation Method

- ex) AQ2A20-20DCM
- Standard Weight : AQ2B20-20D152g
 - Extra Weight : Attachment both end tap type6g
 - Rod end male thread10g
 - Rubber cushion attached5g
- 173g

Item Number of Auto Switch Band

Type of Auto Switch	Item Number of Band	Applied Tube Internal Diameter
W4	BQ-1	12~25
	BQ-2	32~125

- ACP
- APM
- AS
- AX
- AM2
- AM
- AL
- ALX
- AQ
- ADQ
- AQ2**
- ADQ2
- AJ
- AJM
- ABK
- ACK1
- NSK
- AG
- NGQ
- AGX
- GX
- NP
- ADR
- AMR
- NDM
- ARD
- NST
- AST
- ASTH
- NLCD
- NLCS

Series AQ2, ADQ2

Construction/Parts List

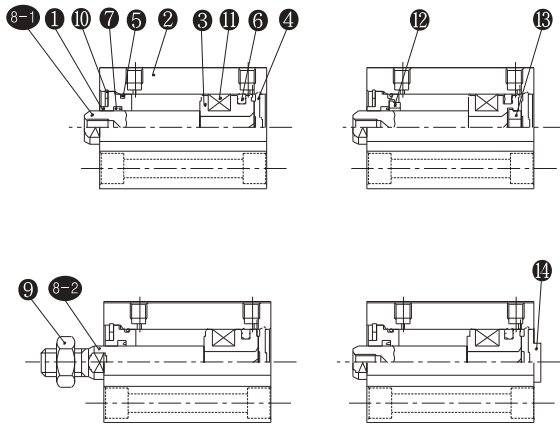

Parts List

No	Item Name	Quantity	Material	Remark
1	Rod Cover	1	Aluminum alloy	Hard Alumite
2	Cylinder Tube	1	Aluminum alloy	
3	Piston	1	Aluminum alloy	Chromite
4	End Plate	1	Aluminum alloy	Hard Alumite
5	Gasket	1	NBR	
6	Piston Packing	1	NBR	
7	Rod Packing	1	NBR	
8-1	Piston Rod	1	Stainless Steel	Female Thread Type
8-2	Piston Rod	1	Stainless Steel	Male Thread Type
9	Rod End Nut	1	Steel	Zinc White Galvanizing
10	Snap Ring	1	Carbon Tool Steel	Black Coloring
11	Magnet	1	NBR+Ba Ferrite	
12	Bumper "A"	1	Polyurethane	Rod Cover Side Equipped
13	Bumper "B"	1	Polyurethane	Piston Side Equipped
14	Nut Ring	1	Aluminum alloy	Hard Alumite

※ In case of Ø12 and Ø16, divided to piston and piston-B.
 ※ In case of Ø12 and Ø16, rear boss mount and end plate do not exist.
 ※ Copper free is basic.
 Notice) Non automatic type carbon steel

Theoretical Force



Bore Size (mm)	Operation Direction	Applied Pressure (MPa)		
		0.3	0.5	0.7
12	IN	25	42	59
	OUT	34	57	79
16	IN	45	75	106
	OUT	60	101	141
20	IN	71	118	165
	OUT	94	157	220
25	IN	113	189	264
	OUT	147	245	344
32	IN	181	302	422
	OUT	241	402	563
40	IN	317	528	739
	OUT	377	628	880
50	IN	495	825	1150
	OUT	589	982	1370
63	IN	841	1400	1960
	OUT	935	1560	2180
80	IN	1360	2270	3170
	OUT	1510	2510	3520
100	IN	2140	3570	5000
	OUT	2360	3930	5500

1N ≐ 0.102kgf
 1MPa ≐ 10.2kgf/cm²

Rod End Nut

Material : Rolled Steel Materials

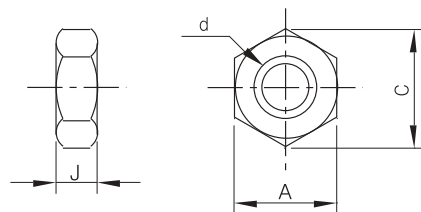

Item Number	Applied Bore Size (mm)	d	J	A	C
M5×0.8-PL	12	M5 × 0.8	4	8	9.2
M6×1.0-PL	16	M6 × 1	5	10	11.5
TNT-02	20	M8 × 1.25	5	13	15.0
TNT-03	25	M10 × 1.25	6	17	19.6
TNT-04	32, 40	M14×1.5	8	22	25.4
TNT-05	50, 63	M18×1.5	11	27	31.2
TNT-08	80	M22×1.5	13	32	37.0
TNT-10	100	M26×1.5	16	41	47.3

Seal Kit/Exchanging Parts/Air Pressure (no-lubrication) Type

NO	Item Number	Material	Ø12	Ø16	Ø20	Ø25	Ø32	Ø40	Ø50	Ø63	Ø80	Ø100
5	GASKET	NBR	C-10	C-14	C-18	C-22	C-29	C-36	C-46	C-60	C-75	C-95
6	PISTON PACKING	NBR	TPSA-12	TPSA-16	TPSA-20	TPSA-25	PPD-32	PPD-40	PPD-50	PPD-63	PPD-80	PPD-100
7	ROD PACKING	NBR	DYR-6K	DYR-8K	DYR-10SK	DYR-12	DYR-16	PDU-16Z	PDU-20Z	PDU-20Z	PDU-25Z	PDU-30Z

Series AQ2, ADQ2

Standard Type (Through Hole Type)/AQ2B, ADQ2B

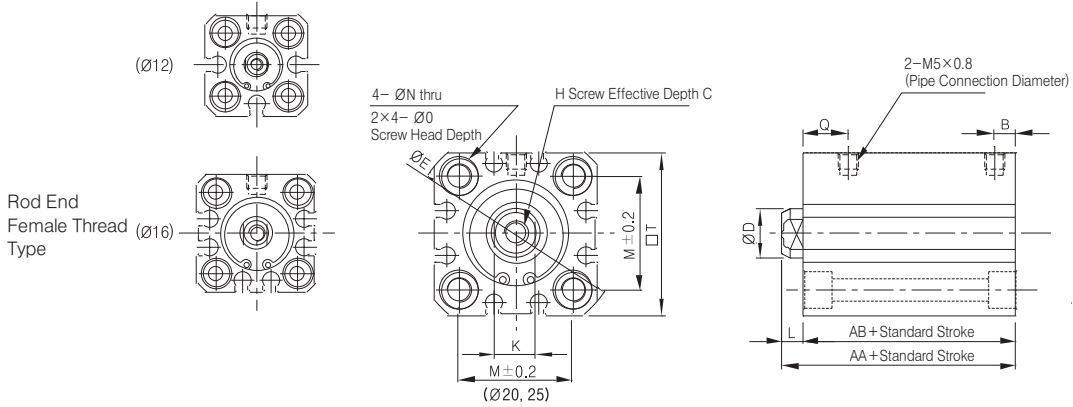

Rod End Female Thread Type

Rod End Male Thread Type

Rod End Male Thread Type (Unit : mm)

Bore Size	L1	C1	H1	X
12	14	9	M5×0.8	10.5
16	15.5	10	M6×1.0	12
20	18.5	12	M8×1.25	14
25	22.5	15	M10×1.25	17.5

Rear Boss Mount Type (Unit : mm)

Bore Size	G	ØThg
20	2	13 ⁰ _{-0.043}
25	2	15 ⁰ _{-0.043}

Standard Type (Unit : mm)

Bore Size	Range of Standard Stroke	Standard Type										Long Stroke	Long Stroke					D	N	K	E	M	□T
		No Auto Switch					Auto Switch Exists						No Auto Switch										
		AA	AB	L	Q	B	AA	AB	L	Q	B		AA	AB	L	Q	B						
12	5~30	20.5	17	3.5	7.5	5	31.5	28	3.5	11	6.5	35~50	45.5	32	13.5	7.5	7.5	6	3.5	5	32	15.5	25
16	5~30	22	18.5	3.5	8	5.5	34	30.5	3.5	11	5.5	35~50	45.5	32	13.5	7.5	7.5	8	3.5	6	38	20	29
20	5~50	24	19.5	4.5	10.5	5.5	36	31.5	4.5	10.5	5.5	~	-	-	-	-	-	10	5.5	8	47	25.5	36
25	5~50	27.5	22.5	5	11	5.5	37.5	32.5	5	11	5.5	~	-	-	-	-	-	12	5.5	10	52	28	40

Bore Size	H	C	O
12	M3×0.5	6	6.5 Depth 4
16	M4×0.7	8	6.5 Depth 4
20	M5×0.8	7	9 Depth 7
25	M6×1.0	12	9 Depth 7

- * If auto switch does not exist, Ø12~5 stroke, Ø20/25~5/10 stroke has penetrated both ends for attachment bolt of tube.
- * In case of rubber cushion attachment, external dimension is same as standard type above.
- * Refer to p.333 for both-end tap.

- ACP
- APM
- AS
- AX
- AM2
- AM
- AL
- ALX
- AQ
- ADQ
- AQ2**
- ADQ2**
- AJ
- AJM
- ABK
- ACK1
- NSK
- AG
- NGQ
- AGX
- GX
- NP
- ADR
- AMR
- NDM
- ARD
- NST
- AST
- ASTH
- NLCD
- NLCS

Series AQ2, ADQ2

Standard Type (Through Hole Type)/AQ2B, ADQ2B

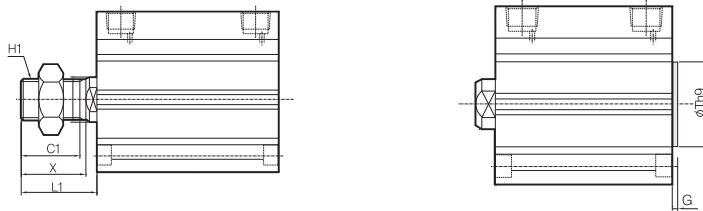
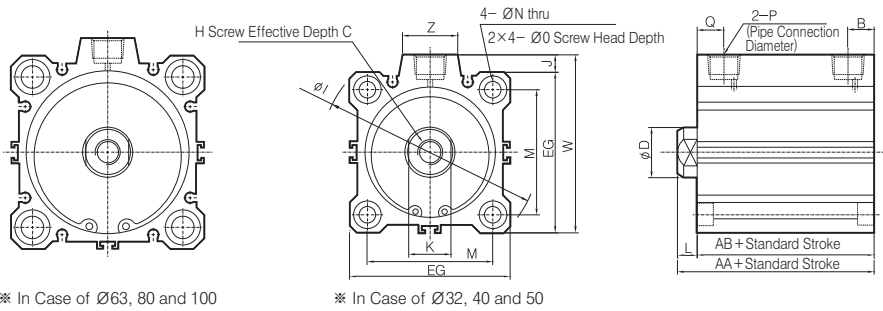

Standard Type

(Unit : mm)

Bore Size	Range of Standard Stroke	Standard Stroke										C	D	EG	H	I	J	K	L	M	N	ϕO	W	Z	
		No Auto Switch					Auto Switch Exists																		
		AA	AB	B	P	Q	AA	AB	B	P	Q														
$\phi 32$	5			5.5	M5×0.8	11.5																			
	10~50	30	23	7.5	Rc(PT) 1/8	10.5	40	33	7.5	Rc(PT) 1/8	10.5	13	16	45	M8×1.25	60	4.5	14	7	34	5.5	9 Depth 7	49.5	14	
	75, 100	40	33	7.5	1/8	10.5																			
$\phi 40$	5~50	36.5	29.5	8	Rc(PT) 1/8	11	46.5	39.5	8	Rc(PT) 1/8	11	13	16	52	M8×1.25	69	5	14	7	40	5.5	9 Depth 7	57	14	
	75, 100	46.5	39.5	8	1/8	14																			
	10~50	38.5	30.5	10.5	Rc(PT) 1/4	10.5	48.5	40.5	10.5	Rc(PT) 1/4	10.5	15	20	64	M10×1.5	87	7	17	8	50	6.6	11 Depth 8	71	22	
$\phi 50$	75, 100	48.5	40.5	10.5	1/4	14																			
	10~50	44	36	10.5	Rc(PT) 1/4	15	54	46	10.5	Rc(PT) 1/4	15	15	20	77	M10×1.5	103	7	17	8	60	9	14 Depth 10.5	84	22	
	75, 100	54	46	10.5	1/4	16.5																			
$\phi 63$	10~50	53.5	43.5	12.5	Rc(PT) 3/8	16	63.5	53.5	12.5	Rc(PT) 3/8	16	21	25	98	M16×2.0	132	6	22	10	77	11	17.5 Depth 13.5	104	26	
	75, 100	63.5	53.5	12.5	3/8	19																			
	10~50	65	53	13	Rc(PT) 3/8	23	75	63	13	Rc(PT) 3/8	23	27	30	117	M20×2.5	156	6.5	27	12	94	11	17.5 Depth 13.5	123.5	26	
$\phi 80$	75, 100	75	63	13	3/8	23																			
	10~50	65	53	13	Rc(PT) 3/8	23	75	63	13	Rc(PT) 3/8	23	27	30	117	M20×2.5	156	6.5	27	12	94	11	17.5 Depth 13.5	123.5	26	
	75, 100	75	63	13	3/8	23																			

※ In case of long stroke (101~3000ST), refer to p.327 (long stroke series)

Rod End Male Thread Type

(unit : mm)

Bore Size	C1	H1	L1	X
$\phi 32$	20.5	M14×1.5	28.5	23.5
$\phi 40$	20.5	M14×1.5	28.5	23.5
$\phi 50$	26	M18×1.5	33.5	28.5
$\phi 63$	26	M18×1.5	33.5	28.5
$\phi 80$	32.5	M22×1.5	43.5	35.5
$\phi 100$	32.5	M26×1.5	43.5	35.5

Rear Boss Mount Type

Bore Size	G	ϕThg
$\phi 32$	2	21 ⁰ _{-0.052}
$\phi 40$	2	28 ⁰ _{-0.052}
$\phi 50$	2	35 ⁰ _{-0.062}
$\phi 63$	2	35 ⁰ _{-0.062}
$\phi 80$	2	43 ⁰ _{-0.062}
$\phi 100$	2	59 ⁰ _{-0.074}

Series AQ2, ADQ2

Foot Type/A(D)Q2L

Ø12~Ø25

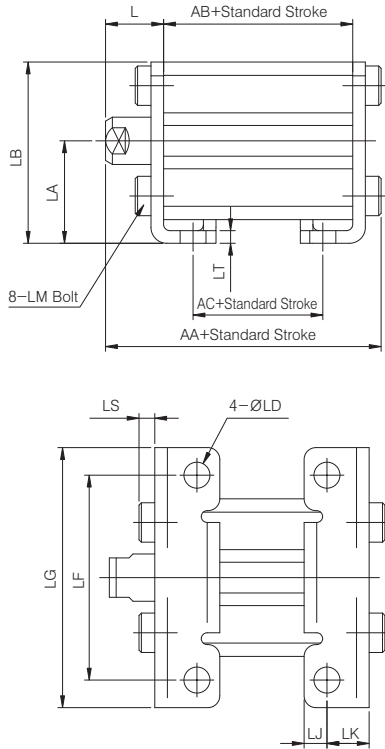

Ø32~Ø100

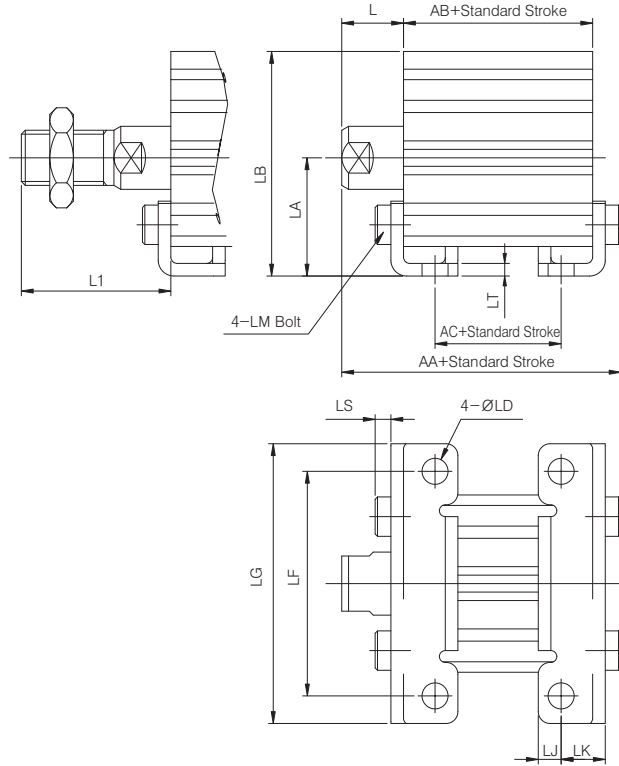

Material : Carbon Steel

(Unit : mm)

Bore Size (Ø)	Range of Standard Stroke	Range of Standard Stroke						L	L1	LA	LB	LD	LF	LG	LJ	LM	LK	LS	LT
		No Auto Switch			Auto Switch Exists														
		AA	AB	AC	AA	AB	AC												
12	5~30	35.3	17	5	46.3	28	16	13.5	24	17	29.5	4.5	34	44	4.5	M4×0.7	8	2.8	2
	35~50	48.3	32	20	55.5	32	20												
16	5~30	36.8	18.5	6.5	48.8	30.5	18.5	13.5	25.5	19	33.5	4.5	38	48	5	M4×0.7	8	2.8	2
	35~50	48.3	32	20	55.5	32	20												
20	5~50	41.2	19.5	7.5	53.2	31.5	19.5	14.5	28.5	24	42	6.6	48	62	5.8	M6×1.0	9.2	4	3.2
25	5~50	44.7	22.5	7.5	54.7	32.5	17.5	15	32.5	26	46	6.6	52	66	5.8	M6×1.0	10.7	4	3.2
32	5~50	47.2	23	7	57.2	33	17	17	28.5	30	57	6.6	57	71	5.8	M6×1.0	11.2	4	3.2
	75,100	57.2	33	17															
40	5~50	53.7	29.5	13.5	63.7	39.5	23.5	17	28.5	33	64	6.6	64	78	7	M6×1.0	11.2	4	3.2
	75,100	63.7	39.5	23.5															
50	10~50	56.7	30.5	7.5	66.7	40.5	17.5	18	33.5	39	78	9	79	95	8	M8×1.25	14.7	5	3.2
	75,100	66.7	40.5	17.5															
63	10~50	62.2	36	10	72.2	46	20	18	33.5	46	91.5	11	95	113	9	M10×1.5	16.2	5	3.2
	75,100	72.2	46	20															
80	10~50	75	43.5	13.5	85	53.5	23.5	20	43.5	59	114	13	118	140	11	M12×1.75	19.5	7	4.5
	75,100	85	53.5	23.5															
100	10~50	88	53	19	98	63	29	22	43.5	71	136	13	137	162	12.5	M12×1.75	23	7	6
	75,100	98	63	29															

※ In case of mounting attached cylinder, A-type tube is standard.
 ※ Indication and dimension are same as dimension of standard cylinder.
 ※ Cylinder and double clevis are delivered without assembly.

- ACP
- APM
- AS
- AX
- AM2
- AM
- AL
- ALX
- AQ
- ADQ
- AQ2**
- ADQ2**
- AJ
- AJM
- ABK
- ACK1
- NSK
- AG
- NGQ
- AGX
- GX
- NP
- ADR
- AMR
- NDM
- ARD
- NST
- AST
- ASTH
- NLCD
- NLCS

Series AQ2, ADQ2

Rod Side Flange Type/A(D)Q2F

Ø12~Ø25

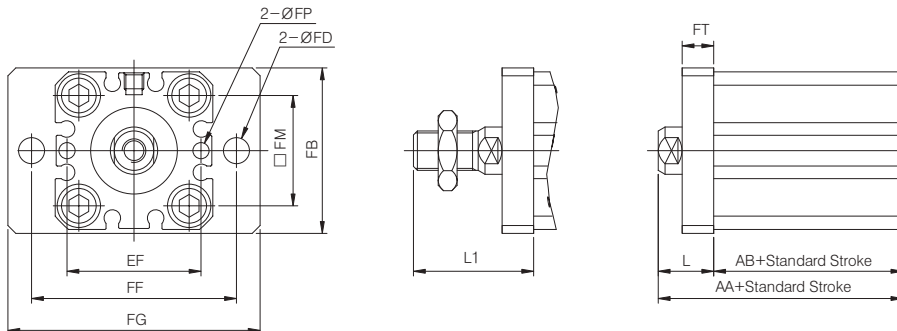

Ø32~Ø100

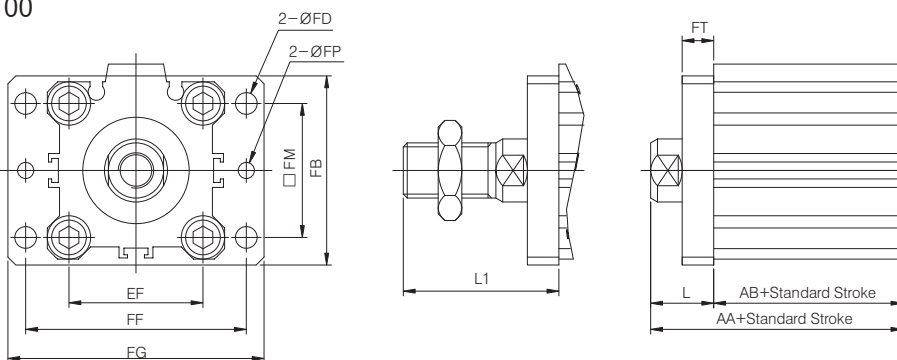

Material : Carbon Steel

(Unit : mm)

Bore Size (Ø)	Range of Standard Stroke	Range of Standard Stroke				L	L1	FB	FD	FP	FE	FF	FG	FM	FN	FT
		No Auto Switch		Auto Switch Exists												
		AA	AB	AA	AB											
12	5~30	30.5	17	41.5	28	13.5	24	25	4.5	3.1	23	45	55	15.5	-	5.5
	35~50	55.5	32	55.5	32											
16	5~30	32	18.5	44	30.5	13.5	25.5	30	4.5	3.1	24	45	55	20	-	5.5
	35~50	55.5	32	55.5	32											
20	5~50	34	19.5	46	31.5	14.5	28.5	39	6.6	3.1	28	48	60	25.5	-	8
25	5~50	37.5	22.5	47.5	32.5	15	32.5	42	6.6	4.1	34	52	64	28	-	8
32	5~50	40	23	50	33	17	38.5	48	5.5	4.1	-	56	65	34	34	8
	75,100	50	33													
40	5~50	46.5	29.5	56.5	39.5	17	38.5	54	5.5	4.1	-	62	72	40	40	8
	75,100	58.5	39.5													
50	5~50	54	36	64	46	18	43.5	67	6.6	5.1	-	76	89	50	50	9
	75,100	58.5	40.5													
63	10~50	54	36	64	46	18	43.5	80	9	5.1	-	92	108	60	60	9
	75,100	64	46													
80	10~50	63.5	43.5	73.5	53.5	20	53.5	99	11	6.1	-	116	134	77	77	11
	75,100	73.5	53.5													
100	10~50	75	53	85	63	22	53.5	117	11	6.1	-	136	154	94	94	11
	75,100	85	63													

※ In case of mounting attached cylinder, A-type tube is standard.
 ※ Indication and dimension are same as dimension of standard cylinder.
 ※ Cylinder and double clevis are delivered without assembly.

Series AQ2, ADQ2

Head-Side flange Type/A(D)Q2G

Ø12~Ø25

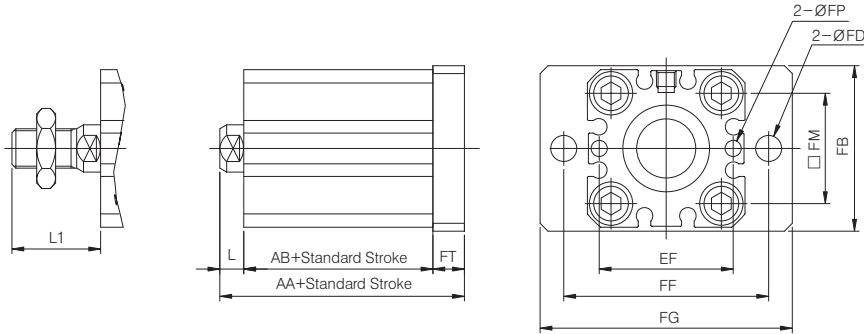

Ø32~Ø100

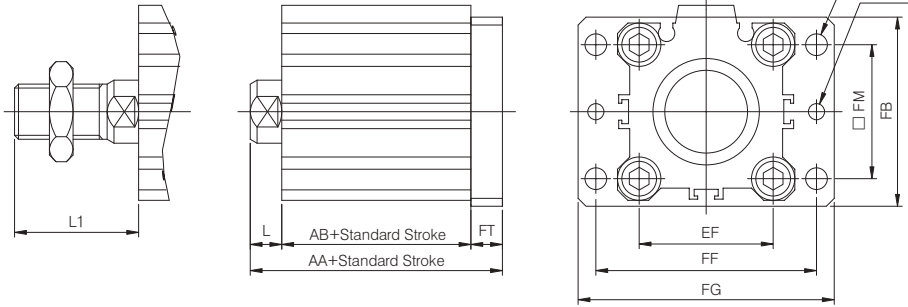

- ACP
- APM
- AS
- AX
- AM2
- AM
- AL
- ALX
- AQ
- ADQ
- AQ2**
- ADQ2**
- AJ
- AJM
- ABK
- ACK1
- NSK
- AG
- NGQ
- AGX
- GX
- NP
- ADR
- AMR
- NDM
- ARD
- NST
- AST
- ASTH
- NLCD
- NLCS

Material : Carbon Steel

(Unit : mm)

Bore Size (Ø)	Range of Standard Stroke	Range of Standard Stroke				L	L1	FB	FD	FP	FE	FF	FG	FM	FN	FT
		No Auto Switch		Auto Switch Exists												
		AA	AB	AA	AB											
12	5~30	26	17	37	28	3.5	14	25	4.5	3.1	45	23	55	15.5	-	5.5
	35~50	51	32	51	32	13.5	24									
16	5~30	27.5	18.5	39.5	30.5	3.5	15.5	30	4.5	3.1	45	24	55	20	-	5.5
	35~50	51	32	51	32	13.5	25.5									
20	5~50	32	19.5	44	31.5	4.5	18.5	39	6.6	3.1	48	28	60	25.5	-	8
25	5~50	35.5	22.5	45.5	32.5	5	22.5	42	6.6	4.1	52	34	64	28	-	8
32	5~50	38	23	48	33	7	28.5	48	5.5	4.1	-	56	65	34	34	8
	75,100	48	33													
40	5~50	44.5	29.5	54.5	39.5	7	28.5	54	5.5	4.1	-	62	72	40	40	8
	75,100	54.5	39.5													
50	5~50	47.5	30.5	57.5	40.5	8	33.5	67	6.6	5.1	-	76	89	50	50	9
	75,100	57.5	40.5													
63	10~50	53	36	63	46	8	33.5	80	9	5.1	-	92	108	60	60	9
	75,100	63	46													
80	10~50	64.5	43.5	74.5	53.5	10	43.5	99	11	6.1	-	116	134	77	77	11
	75,100	74.5	53.5													
100	10~50	76	53	86	63	12	43.5	117	11	6.1	-	136	154	94	94	11
	75,100	86	63													

※ In case of mounting attached cylinder, A-type tube is standard.
 ※ Indication and dimension are same as dimension of standard cylinder.
 ※ Cylinder and double clevis are delivered without assembly.

Series AQ2, ADQ2

Double Rear Clevis/A(D)Q2D

Ø12~Ø25

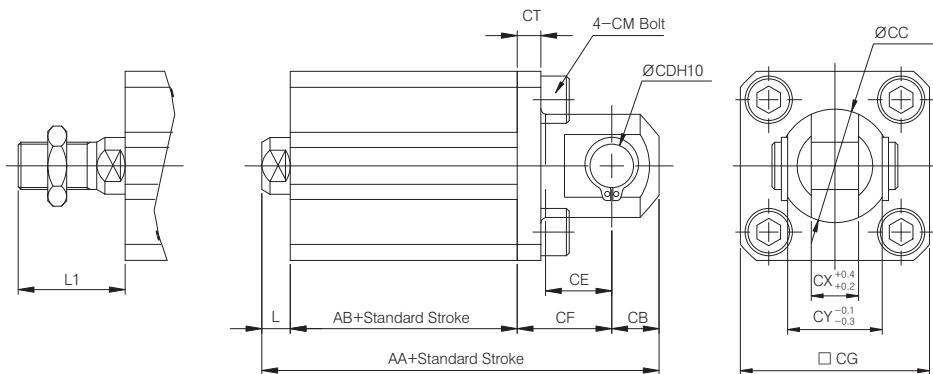

Ø32~Ø100

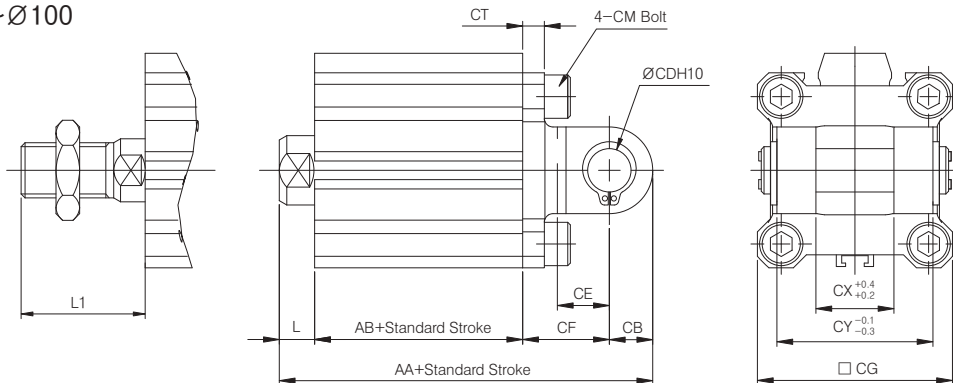

Material: Ø12~Ø25—Carbon Steel, Ø32~Ø100—Cast Iron

(Unit : mm)

Bore Size (Ø)	Range of Standard Stroke	Range of Standard Stroke				L	L1	CB	CE	CF	CG	CM	CD	CT	CX	CY	CC (Ø)	
		No Auto Switch		Auto Switch Exists														
		AA	AB	AA	AB													
12	5~30	40.5	17	51.5	28	3.5	14	6	7	14	25	M4×0.7	5	^{+0.05} ₀	4	5	10	12
	35~50	65.5	32	65.5	32	13.5	24											
16	5~30	43	18.5	55	30.5	3.5	15.5	6	10	15	29	M4×0.7	5	^{+0.05} ₀	4	6.5	12	14
	35~50	66.5	32	66.5	32	13.5	25.5											
20	5~50	51	19.5	63	31.5	4.5	18.5	9	12	18	36	M6×1.0	8	^{+0.06} ₀	5	8	16	20
25	5~50	57.5	22.5	67.5	32.5	5	22.5	10	14	20	40	M6×1.0	10	^{+0.06} ₀	5	10	20	24
32	5~50	60	23	70	33	7	28.5	10	14	20	45	M6×1.0	10	^{+0.06} ₀	5	18	36	-
	75,100	70	33															
40	5~50	68.5	29.5	78.5	39.5	7	28.5	10	14	22	52	M6×1.0	10	^{+0.06} ₀	6	18	36	-
	75,100	78.5	39.5															
50	10~50	80.5	30.5	90.5	40.5	8	33.5	14	20	28	64	M8×1.25	14	^{+0.07} ₀	7	22	44	-
	75,100	90.5	40.5															
63	10~50	88	36	98	46	8	33.5	14	20	30	77	M10×1.5	14	^{+0.07} ₀	8	22	44	-
	75,100	98	46															
80	10~50	109.5	43.5	119.5	53.5	10	43.5	18	27	38	98	M12×1.75	18	^{+0.07} ₀	10	28	56	-
	75,100	119.5	53.5															
100	10~50	132	53	142	63	12	43.5	22	31	45	117	M12×1.75	22	^{+0.084} ₀	10	32	56	-
	75,100	142	63															

* In case of mounting attached cylinder, A-type tube is standard.
 * Indication and dimension are same as dimension of standard cylinder.
 * Cylinder and double clevis are delivered without assembly.

Series AQ2, ADQ2

Single Knuckle Joint

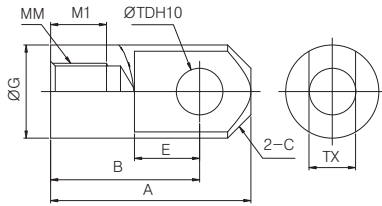

Double Knuckle Joint

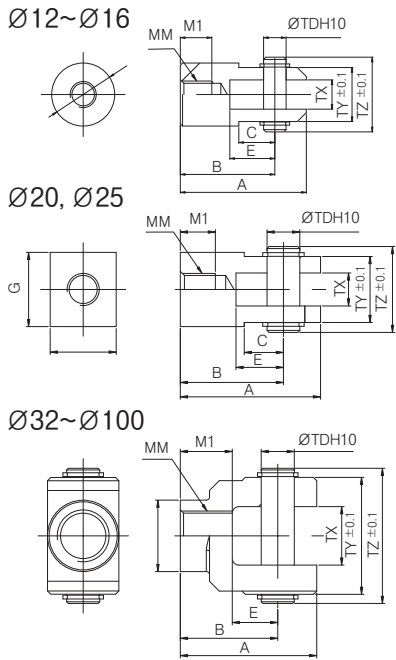

Double Knuckle Joint Pin/Double Clevis Pin

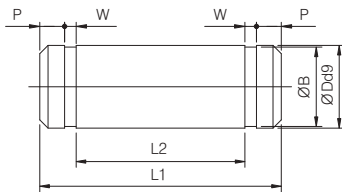

Rod End Nut

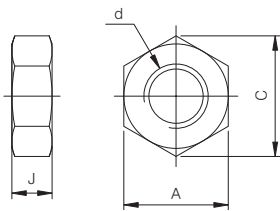

Material : Carbon Steel

(Unit : mm)

Item No.	Bore of Applied Cylinder (mm)	A	B	C	E	G (Ø)	MM	MI	ØTDH10	TX
QI-012	12	21.5	16	2.5	7	12	M5×0.8	6	5 +0.048 0	5 -0.2 -0.4
QI-016	16	32	25	3	14	14	M6×1.0	8	5 +0.048 0	6.4 -0.2 -0.4
QI-020	20	34	25	4	11.5	18	M8×1.25	8.5	8 +0.058 0	8 -0.2 -0.4
QI-025	25	41	30	5	14	23	M10×1.25	10.5	10 +0.058 0	10 -0.2 -0.4
QI-032	32,40	42	30	6	14	29	M14×1.5	14	10 +0.058 0	18 -0.3 -0.5
QI-050	50,63	56	40	6.5	20	36	M18×1.5	18	14 +0.070 0	22 -0.3 -0.5
QI-080	80	71	50	8	27	38	M22×1.5	21	18 +0.070 0	28 -0.3 -0.5
QI-100	100	79	55	10	31	44	M26×1.5	21	22 +0.084 0	32 -0.3 -0.5

Material: Ø12~Ø25—Carbon Steel, Ø32~Ø100—Cast Iron

(Unit : mm)

Item No.	Bore of Applied Cylinder (mm)	A	B	C	E	G	F	MM	MI	ØTDH10	TX	TY	TZ
QY-012	12	21.5	16	6	7	Ø12	-	M5×0.8	6	5 +0.048 0	5 -0.4 -0.2	10	14.6
QY-016	16	28	21	8	10	Ø14	-	M6×1.0	7	5 +0.048 0	6.5 -0.4 -0.2	12	16.6
QY-020	20	34	25	9.5	11.5	Ø18	16	M8×1.25	8.5	8 +0.058 0	8 -0.4 -0.2	16	21
QY-025	25	41	30	14	14	Ø22	20	M10×1.25	10.5	10 +0.058 0	10 -0.4 -0.2	20	25.6
QY-032	32,40	42	30	-	14	Ø22	-	M14×1.5	16	10 +0.058 0	18 -0.5 -0.3	36	41.6
QY-050	50,63	56	40	-	20	Ø28	-	M18×1.5	20	14 +0.070 0	22 -0.5 -0.3	44	50.6
QY-080	80	71	50	-	27	Ø38	-	M22×1.5	23	18 +0.070 0	28 -0.5 -0.3	56	64
QY-100	100	79	55	-	31	Ø44	-	M26×1.5	24	22 +0.084 0	32 -0.5 -0.3	64	72

Material : Carbon Steel

(Unit : mm)

Item No.	Bore of Applied Cylinder (mm)	ØDd9	L1	L2	P	W	B	Snapping
QP-012	12	5 -0.03 -0.06	14.6	10.2	1.5	0.7	4.7	C Type for Shaft 5
QP-016	16	5 -0.03 -0.06	16.6	12.2	1.5	0.7	4.7	C Type for Shaft 5
QP-020	20	8 -0.04 -0.076	21	16.2	1.5	0.9	7.5	C Type for Shaft 5
QP-025	25	10 -0.040 -0.076	25.6	20.2	1.55	1.15	9.4	C Type for Shaft 10
QP-032	32,40	10 -0.040 -0.076	41.6	36.2	1.55	1.15	9.4	C Type for Shaft 10
QP-050	50,63	14 -0.050 -0.076	50.6	44.2	2.05	1.15	13.1	C Type for Shaft 14
QP-080	80	18 -0.050 -0.093	64	56.2	2.55	1.35	16.8	C Type for Shaft 18
QP-100	100	22 -0.065 -0.117	72	64.2	2.55	1.35	20.8	C Type for Shaft 22

Material : Carbon Steel

(Unit : mm)

Item No.	Bore of Applied Cylinder (mm)	d	J	A	C
M5×0.8-PL	12	M5×0.8	4	8	9.2
M5×0.8-PL	16	M6×1.0	5	10	11.5
TNT-02	20	M8×1.25	5	13	15
TNT-03	25	M10×1.25	6	17	19.6
TNT-04	32,40	M14×1.5	8	22	25.4
TNT-05	50,63	M18×1.5	11	27	31.2
TNT-08	80	M22×1.5	13	32	37.0
TNT-10	100	M26×1.5	16	41	47.3

- ACP
- APM
- AS
- AX
- AM2
- AM
- AL
- ALX
- AQ
- ADQ
- AQ2**
- ADQ2**
- AJ
- AJM
- ABK
- ACK1
- NSK
- AG
- NGQ
- AGX
- GX
- NP
- ADR
- AMR
- NDM
- ARD
- NST
- AST
- ASTH
- NLCD
- NLCS

Series AQ2W, ADQ2W

Compact Cylinder(Square Tybe) : Standard Type/Double Acting-Double Rod

Bore Size(mm) : Ø12, Ø16, Ø32, Ø40, Ø50, Ø63, Ø80, Ø100

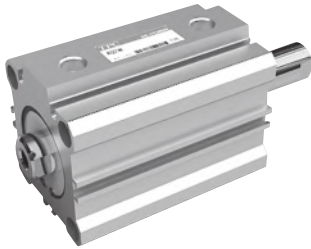

- DOUBLE ROD COMPACT CYLINDER
- SPACE SAVING CYLINDER
- COMPACT EQUIPMENT DESIGN AVAILABLE
- SMALL AUTO SWITCH EQUIPPED IN SQUARE TUBE

Symbol

Double Acting : Double Rod

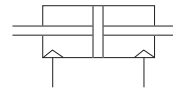

How to Order

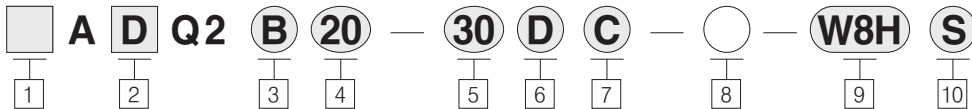

1 Magnet

Blank : Rc(PT)
U : NPT

2 Magnet

Blank : None
D : Built-in Magnet

3 Mounting

B : Through hole (standard type)
A : Both end tapped
F : Rod side flange (standard both end type)
L : Foot (standard both end type)
※ Mountings are delivered without assembly

4 Bore Size

12 : 12mm(1/2Nom.)	40 : 40mm(1 1/2Nom.)
16 : 16mm(5/8Nom.)	50 : 50mm(2Nom.)
20 : 20mm(3/4Nom.)	63 : 63mm(2 1/2Nom.)
25 : 25mm(1Nom.)	80 : 80mm(3 1/4Nom.)
32 : 32mm(1 1/4Nom.)	100 : 100mm(4Nom.)

5 Stroke(mm)

Bore Size	Standard Stroke
12, 16	: 5, 10, 15, 20, 25, 30
32, 40	: 5, 10, 15, 20, 25, 30, 35, 40, 45, 50, 75, 100
50~100	: 10, 15, 20, 25, 30, 35, 40, 45, 50, 75, 100

6 Action

D : Double Acting Type

7 Body Option

Blank : Standard type
(Rod end female thread)
C : Rubber Cushion Attached

M : Rod end male thread

F : Rear boss mount

I : Single knuckle joint (rod end male thread)

Y : Double Knuckle Joint (rod end male thread)

※ Possible to combine body specification
(CM, CF, CI, CF, CF, CFY, etc.)

※ ø 12 and ø 16 are not available for F

※ I and Y are delivered without assembly

8 Special Option

Blank : Standard type
XC16 : Copper-free
※ Ø12~Ø40 : XC16 is standard type

9 Auto switch

Blank : None
Reed switch
W4 : W4 (Ø32~Ø100)
W8(HV) : Subcompact auto switch
horizontal (vertical) type, 2 wire type
Non contact auto switch
W9(HV) : Subcompact auto switch
horizontal (vertical) type, 2 wire type
W9(HV)N : Subcompact auto switch
horizontal (vertical) type, 3 wire type
W2P(L) : Ø50~Ø100
※ In case of 3m lead line, L should be added at the end of item number
※ In case of 5m lead line, please contact us

10 Number of Auto Switches

Blank : 2 pcs
S : 1 pc
N : N pcs

Item Number of Mountings

Bore Size (mm)	Foot	Flange	Double Clevis
12	QL-012	QF-012	QD-012
16	QL-016	QF-016	QD-016
32	QL-032	QF-032	QD-032
40	QL-040	QF-040	QD-040
50	QL-050	QF-050	QD-050
63	QL-063	QF-063	QD-063
80	QL-080	QF-080	QD-080
100	QL-100	QF-100	QD-100

※ In case of ordering foot fittings, please order 2EA foot fittings per 1EA cylinder

● Notice

※ Production of middle stroke

Minimum 3mm to 1mm middle stroke production is available by means of mountings spacer at standard stroke cylinder.

ex) AQ2B32-27D inserts 3mm wide spacer in standard cylinder AQ2B32-30D

ex) AQ2B32-29D inserts 21mm wide spacer in standard cylinder AQ2B32-50D

Series AQ2W, ADQ2W

Notices for products

Please fully understand the notices prior to utilization, and refer to safety notice and common notice.

Warning

Assembly/Disassembly of Snap Ring

- Please use proper flyer (Attached tool of C-type snap ring) for assembly / disassembly.
- Please be cautious all the time, there is possible damage to human body or vicinity equipments owing to projection of snap ring at the end of flyer (C-type snap ring) in spite of using proper flyer (Attached tool of C-type snap ring). Moreover, after checking full connection of snap ring during attachment, supply air.

Mounting

- Loading removing should be carried out with fixing load side piston rod 2 face width part.
- If load-side piston rod is not firmly fixed, connecting part (screw fixing part) of piston rod is possibly released.

Options

		Bore Size(mm)							
		12	16	32	40	50	63	80	100
Air	Mounting	Through-hole	○	○	○	○	○	○	○
		Both ends Tap	○	○	○	○	○	○	○
Pressure	Piping Method	Built-In Magnet	○	○	○	○	○	○	○
		Thread Type	M5×0.8	M5×0.8 ^{mm} Rc(PT)1/8	Rc(PT)1/8	Rc(PT)1/4	Rc(PT)3/8		
Type	Rod end Male Thread		○	○	○	○	○	○	○
		Rubber Cushion Mount	○	○	○	○	○	○	○

(Note1) When requiring style without auto switch, M5×0.8 for 5mm stroke only.

Specification

Type	Air Pressure (non-lubrication) Type
Applied Fluid	Air
Guaranteed Pressure Resistance	1.5MPa{15.3kgf/cm ² }
Maximum Pressure Applied	1.0MPa{9.9kgf/cm ² }
Ambient and Applied Fluid Temperature	-10℃~70℃(No Frozen)
Rod end Thread	KS Class 2
Stroke Tolerance	+1.0 0
Piston Speed	50~500mm/s
Rubber Cushion	None
Rod end Thread	Female Thread
Mounting	Through Hole

Minimum Operation Pressure (Unit : MPa)

Bore Size(mm)	12	16	32	40	50	63	80	100
Air Pressure (no Fuel) Type	0.07	0.07	0.05	0.05	0.05	0.05	0.05	0.05

Weight Table (Unit : g)

Bore Size (mm)	Cylinder Stroke (mm)					
	5	10	15	20	25	30
12	42	49	56	63	71	77
16	63	74	85	96	107	118
32	192	220	244	268	292	316
40	292	323	354	385	416	447
50	-	528	573	618	663	708
63	-	676	714	753	792	831
80	-	1241	1325	1409	1493	1577
100	-	2106	2225	2344	2463	2582

Option Weights (Unit : g)

Bore Size(mm)	12	16	32	40	50	63	80	100
Attachment Both End Tap Type	1	2	7	6	7	17	31	43
Rod End	Male Thread Part	1.5	3	50	50	104	104	288
	Nut	1	2	34	34	64	64	98
Rubber Cushion Attached	1	2	4	6	10	16	25	42

Calculation Method

- ex) AQ2WA16-20DCM
- Standard Weight : AQ2WB16-20D96g
 - Extra Weight : Attachment both end tap type2g
 - Rod end male thread5g
 - Rubber cushion attached2g
- 105g

- ACP
- APM
- AS
- AX
- AM2
- AM
- AL ALX
- AQ ADQ
- AQ2 ADQ2**
- AJ AJM
- ABK
- ACK1
- NSK
- AG
- NGQ
- AGX GX
- NP
- ADR
- AMR
- NDM
- ARD
- NST
- AST
- ASTH
- NLCD
- NLCS

Series AQ2W, ADQ2W

Construction/Parts List

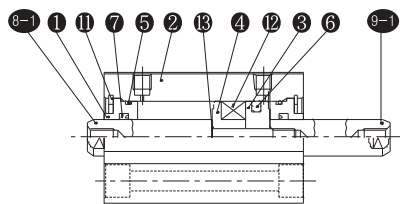

Standard Type

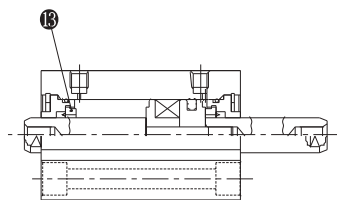

Rubber Cushion Attached

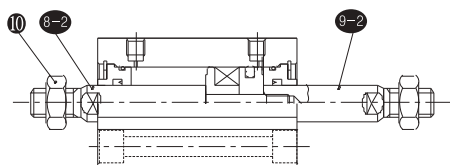

Rod End Male Screw

Theoretical Force

(Unit : N)



Bore Size (mm)	Applied Pressure (MPa)		
	0.3	0.5	0.7
12	25	42	59
16	45	75	106
32	181	302	422
40	317	528	739
50	495	825	1150
63	841	1400	1960
80	1360	2270	3170
100	2140	3570	5000

1N = 0.102kgf
1MPa = 10.2kgf/cm²

Parts List

No	Item Name	Quantity	Material	Remark
1	Rod Cover	2	Aluminum alloy	Hard Alumite
2	Cylinder Tube	1	Aluminum alloy	
3	Piston	1	Aluminum alloy	Chromite
4	Piston-B	1	Aluminum alloy	Chromite
5	Gasket	2	NBR	
6	Piston Packing	1	NBR	
7	Rod Packing	2	NBR	
8-1	Piston Rod-A	1	Stainless Steel	Female Thread Type
8-2	Piston Rod-A	1	Stainless Steel	Male Thread Type
9-1	Piston Rod-B	1	Stainless Steel	Female Thread Type
9-2	Piston Rod-B	1	Stainless Steel	Male Thread Type
10	Rod End Nut	2	Steel	Zinc White Galvanizing
11	Snap Ring	2	Carbon Tool Steel	Black Coloring
12	Magnet	1	NBR+Ba Ferrite	
13	Bumper "A"	2	Polyurethane	Rod Cover Side Equipped

* In case of Ø12 and Ø16, divided to piston and piston-B.
 * In case of Ø12 and Ø16, rear boss mount and end plate do not exist.
 * Copper free is basic.
 Notice) Non automatic type carbon steel

Seal Kits/Exchanging Parts/Air Pressure (non-lubrication) Type

NO	Item Number	Material	Ø12	Ø16	Ø32	Ø40	Ø50	Ø63	Ø80	Ø100
5	GASKET	Rubber	C-10	C-14	C-29	C-36	C-46	C-60	C-75	C-95
6	PISTON PACKING	Rubber	TPSA-12	TPSA-16	PPD-32	PPD-40	PPD-50	PPD-63	PPD-80	PPD-100
7	ROD PACKING	Rubber	DYR-6K	DYR-8K	DYR-16	PDU-16Z	PDU-20Z	PDU-20Z	PDU-25Z	PDU-30Z

Series AQ2W, ADQ2W

Standard Type (Through Hole type)/AQ2WB, ADQ2WB

Rod End
Female Thread Type

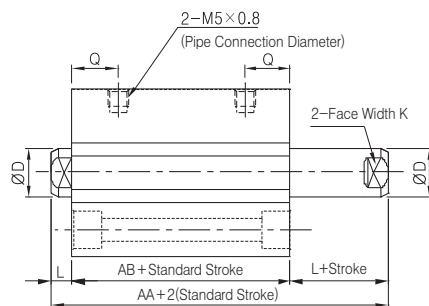
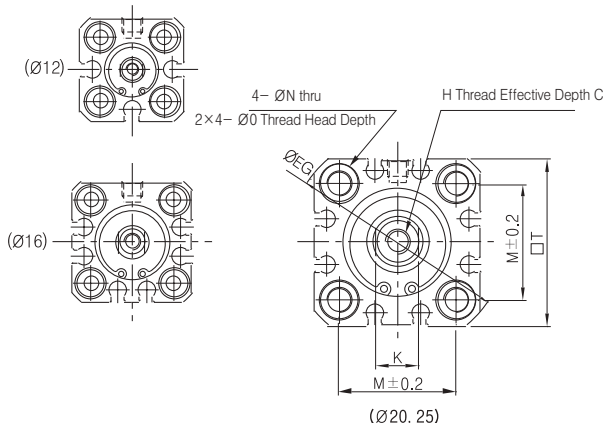

Rod End
Male Thread Type

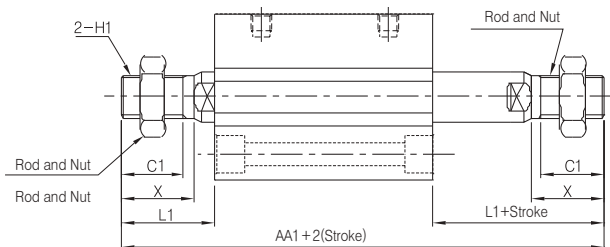

Rod End Male Thread Type

(Unit : mm)

Bore Size	AA1		L1	C1	H1	X
	Non-Auto Switch	Mounting Auto Switch				
12	53.6	60	14	9	M5×0.8	12
16	57	60	15.5	10	M6×1.0	16

Standard Type

(Unit : mm)

Bore Size	Range of Standard Stroke	Non-Auto Switch				Mounting Auto Switch				D	N	K	ØEG	M	□T	H	C	O
		AA	AB	L	Q	AA	AB	L	Q									
12	5 ~ 30	32.6	25.6	3.5	9	39	32	3.5	10.5	6	3.5	5	32	15.5	25	M3×0.5	6	6.5 Depth 4
16	5 ~ 30	33	26	3.5	10	43	36	3.5	10	8	3.5	6	38	20	29	M4×0.7	8	6.5 Depth 4

※ In case of rubber cushion attachment, external dimension is same as standard type above.

※ For both ends tap type, refer to p.333

- ACP
- APM
- AS
- AX
- AM2
- AM
- AL
- ALX
- AQ
- ADQ
- AQ2**
- ADQ2**
- AJ
- AJM
- ABK
- ACK1
- NSK
- AG
- NGQ
- AGX
- GX
- NP
- ADR
- AMR
- NDM
- ARD
- NST
- AST
- ASTH
- NLCD
- NLCS

Series AQ2W, ADQ2W

Standard Type (Through Hole type)/AQ2WB, ADQ2WB

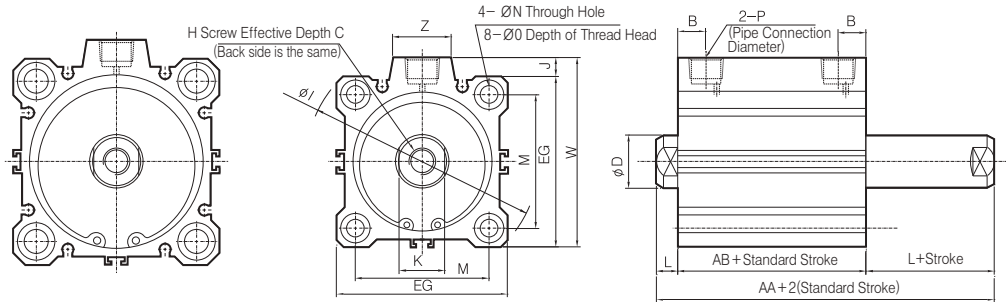

※ In case of $\varnothing 63, 80, 100$

※ In case of $\varnothing 32, 40, 50$

Rod End Male Thread Type

(Unit : mm)

Bore Size	AA1		C1	H1	L1	X
	No Auto Switch	Auto Switch Exists				
$\varnothing 32$	87.5	97.5	20.5	M14x1.5	28.5	23.5
$\varnothing 40$	97	107	20.5	M14x1.5	28.5	23.5
$\varnothing 50$	107.5	117.5	26	M18x1.5	33.5	28.5
$\varnothing 63$	109	119	26	M18x1.5	33.5	28.5
$\varnothing 80$	138	148	32.5	M22x1.5	43.5	35.5
$\varnothing 100$	147.5	157.5	32.5	M26x1.5	43.5	35.5

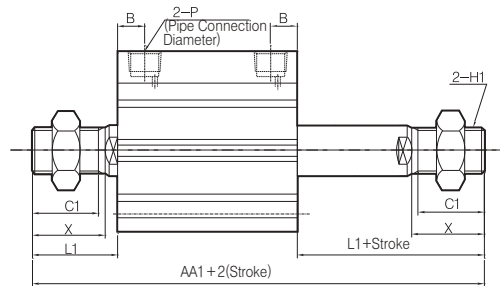

Standard Type

(Unit : mm)

Bore Size	Range of Standard Stroke	Standard Stroke						C	D	EG	B	H	I	J	K	L	M	N	$\varnothing O$	W	Z
		No Auto Switch			Auto Switch Exists																
		AA	AB	P	AA	AB	P														
$\varnothing 32$	5	44.5	30.5	M5 X 0.8	54.5	40.5	Rc(PT) 1/8	13	16	45	12.5	M8X1.25	60	4.5	14	7	34	5.5	9 Depth 7	49.5	14
	10~50	44.5	30.5	Rc(PT) 1/8																	
	75, 100	54.5	40.5																		
$\varnothing 40$	5~50	54	40	Rc(PT) 1/8	64	50	Rc(PT) 1/8	13	16	52	14	M8X1.25	69	5	14	7	40	5.5	9 Depth 7	57	14
	75, 100	64	50																		
$\varnothing 50$	10~50	56.5	40.5	Rc(PT) 1/4	66.5	50.5	Rc(PT) 1/4	15	20	64	14	M10X1.5	87	7	17	8	50	6.6	11 Depth 8	71	22
	75, 100	66.5	50.5																		
$\varnothing 63$	10~50	58	42	Rc(PT) 1/4	68	52	Rc(PT) 1/4	15	20	77	15.5	M10X1.5	103	7	17	8	60	9	14 Depth 10.5	84	22
	75, 100	68	52																		
$\varnothing 80$	10~50	71	51	Rc(PT) 3/8	81	61	Rc(PT) 3/8	21	25	98	18	M16X2.0	132	6	22	10	77	11	17.5 Depth 13.5	104	26
	75, 100	81	61																		
$\varnothing 100$	10~50	84.5	60.5	Rc(PT) 3/8	94.5	70.5	Rc(PT) 3/8	27	30	117	22	M20X2.5	156	6.5	27	12	94	11	17.5 Depth 13.5	123.5	26
	75, 100	94.5	70.5																		

※ Please contact us for longer stroke than basic.

Series AQ2W, ADQ2W

Foot Type/A(D)Q2WL

Ø12~Ø25

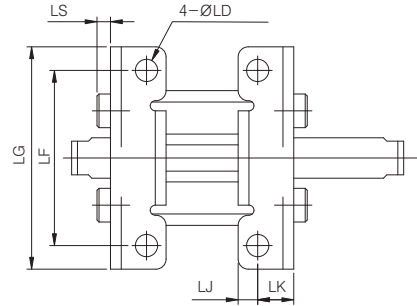
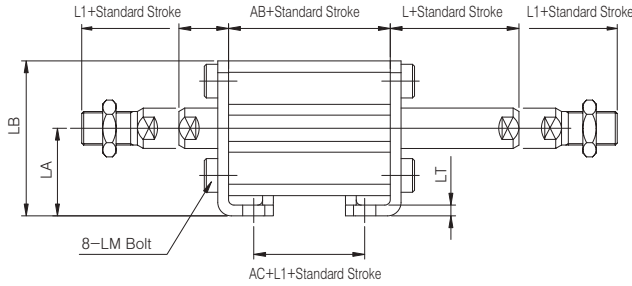

Ø32~Ø100

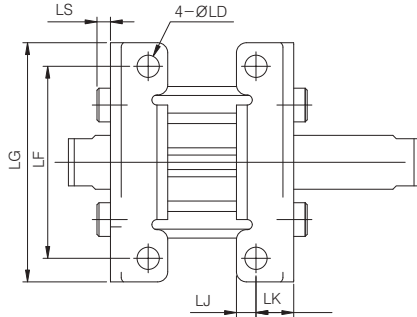
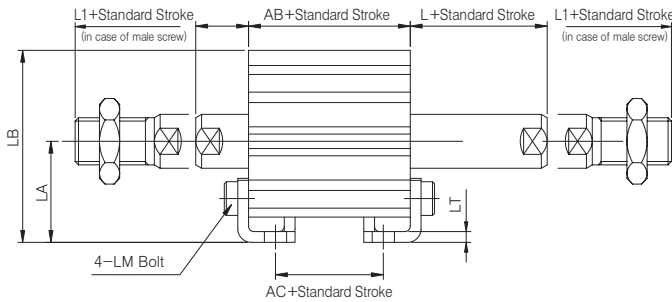

Material : Carbon Steel

(Unit : mm)

Bore Size (Ø)	Range of Standard Stroke	Standard Stroke				L	L1	LA	LB	LD	LF	LG	LJ	LM	LK	LS	LT
		No Auto Switch		Auto Switch Exists													
		AB	AC	AB	AC												
12	5~30	25.6	13.6	32	20	13.5	24	17	29.5	4.5	34	44	4.5	M4×0.7	8	2.8	2
	16	5~30	26	14	36	24	13.5	25.5	19	33.5	4.5	38	48	5	M4×0.7	8	2.8
32	5~50	30.5	14.5	40.5	24.5	17	38.5	30	57	6.6	57	71	5.8	M6×1.0	11.2	4	3.2
	75, 100	40.5	24.5														
40	5~50	40	24	50	34	17	38.5	33	64	6.6	64	78	7	M6×1.0	11.2	4	3.2
	75, 100	50	34														
50	10~50	40.5	17.5	50.5	27.5	18	43.5	39	78	9	79	95	8	M8×1.25	14.7	5	3.2
	75, 100	50.5	27.5														
63	10~50	42	16	52	26	18	43.5	46	91.5	11	95	113	9	M10×1.5	16.2	5	3.2
	75, 100	52	26														
80	10~50	51	21	61	31	20	53.5	59	114	13	118	140	11	M12×1.75	19.5	7	4.5
	75, 100	61	31														
100	10~50	60.5	26.5	70.5	36.5	22	53.5	71	136	13	137	162	12.5	M12×1.75	23	7	6
	75, 100	70.5	36.5														

※ In case of mounting attached cylinder, A-type tube is standard.
 ※ Indication and dimension are same as dimension of standard cylinder.
 ※ Cylinder and fittings are delivered without assembly.
 ※ Please contact us for longer stroke than basic.

- ACP
- APM
- AS
- AX
- AM2
- AM
- AL
ALX
- AQ
ADQ
- AQ2
ADQ2**
- AJ
AJM
- ABK
- ACK1
- NSK
- AG
- NGQ
- AGX
GX
- NP
- ADR
- AMR
- NDM
- ARD
- NST
- AST
- ASTH
- NLCD
- NLCS

Series AQ2W, ADQ2W

Flange Type/A(D)Q2WF

Ø12~Ø25

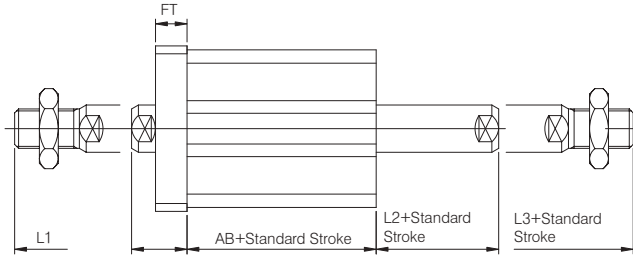
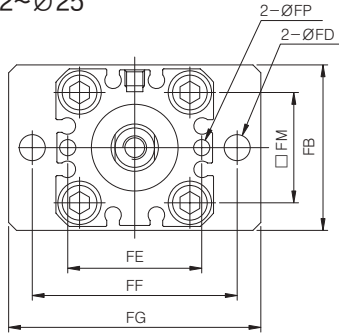

Ø32~Ø100

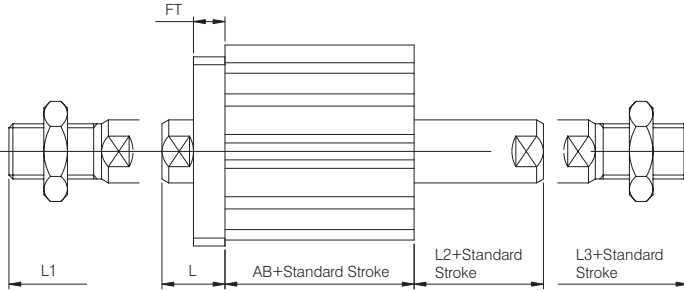
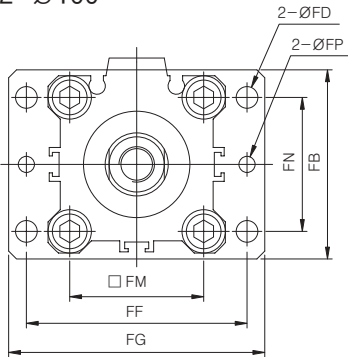

Material : Carbon Steel

(Unit : mm)

Bore Size (Ø)	Range of Standard Stroke	Standard Stroke		L	L1	L2	L3	FB	FD	FP	FE	FF	FG	FM	FN	FT
		No Auto Switch AB	Auto Switch Exist AB													
12	5~30	25.6	32	13.5	24	3.5	14	25	4.5	3.1	23	45	55	15.5	-	5.5
16	5~30	26	36	13.5	25.5	3.5	15.5	30	4.5	3.1	24	45	55	20	-	5.5
32	5~50	30.5	40.5	17	38.5	7	28.5	48	5.5	4.1	-	56	65	34	34	8
	75, 100	40.5														
40	5~50	40	50	17	38.5	7	28.5	54	5.5	4.1	-	62	72	40	40	8
	75, 100	50														
50	10~50	40.5	50.5	18	43.5	8	33.5	67	6.6	5.1	-	76	89	50	50	9
	75, 100	50.5														
63	10~50	42	52	18	43.5	8	33.5	80	9	5.1	-	92	108	60	60	9
	75, 100	52														
80	10~50	51	61	20	53.5	10	43.5	99	11	6.1	-	116	134	77	77	11
	75, 100	61														
100	10~50	60.5	70.5	22	53.5	12	43.5	117	11	6.1	-	136	154	94	94	11
	75, 100	70.5														

- * In case of mounting attached cylinder, A-type tube is standard.
- * Indication and dimension are same as dimension of standard cylinder.
- * Cylinder and fittings are delivered without assembly.
- * Please contact us for longer stroke than basic.

Series AQ2, ADQ2

Compact Cylinder (Square Tube) : Standard Type/Single Acting – Single Rod

Bore Size(mm) : Ø12, Ø16, Ø25, Ø32, Ø40, Ø50



- SINGLE ACTION COMPACT TYPE CYLINDER
- SPACE SAVING CYLINDER
- COMPACT DEVICE DESIGN AVAILABLE
- SMALL AUTO SWITCH EQUIPPED IN SQUARE TUBE

Symbol

Single Action : Single Rod

Retraction type

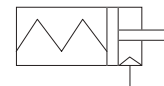
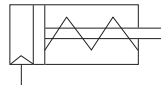

How to Order

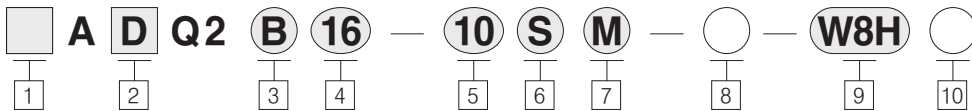

- Magnet**
Blank : Rc(PT)
U : NPT
- Magnet**
Blank : None
D : Built-in magnet
- Mounting**
B : Through hole (standard type)
A : Both end tap (refer to p.323)
D : Double Clevis (standard both end type)
F : Rod side flange (standard both end type)
G : Head side flange (standard both end type)
L : Foot (standard both end type)
※ Mountings are delivered without assembly
- Bore Size**
12 : 12mm(1/2Nom.) 32 : 32mm(1 1/4Nom.)
16 : 16mm(5/8Nom.) 40 : 40mm(1 1/2Nom.)
25 : 25mm(1Nom.) 50 : 50mm(2Nom.)
- Stroke(mm)**
Bore Size Standard Stroke
Ø12, Ø16, Ø25 : 5, 10
Ø32, Ø40, Ø50 : 5, 10
- Action**
S : Single acting extension type
T : Single acting retraction type
※ In case of Ø32, 40 and 50, T single acting retraction are not available.
- Body option**
Blank : Standard type
(rod end female thread)
M : Rod end male thread

- F : Rear boss mount
I : Single knuckle joint (rod end male thread)
Y : Double Knuckle Joint (rod end male thread)
※ Possible to combine body specification (FM, FI, FY)
※ Except F for Ø12 and Ø16 cases
※ I and Y are delivered without assembly
- Series**
Blank : Standard type
XC16 : Copper-free
※ Ø12~Ø40 : XC16 is standard type
 - Auto switch**
Blank : None
Reed switch
W4 : W4 (Ø32~Ø100)
W8H(V) : Subcompact auto switch
horizontal (vertical) type, 2 wire type
Non contact point existing auto switch
W9H(V) : Subcompact auto switch
horizontal (vertical) type, 2 wire type
W9H(V)N : Subcompact auto switch
horizontal (vertical) type, 3 wire type
W2PL : Ø50~Ø100
※ In case of 3m lead wire, L should be added at the end of item number
ex) W4L or W2PL
※ In case of 5m lead wire, please contact us
 - Number of Auto Switches**
Blank : 2 pcs
S : 1 pc
N : N pcs

Item Number of Mounting

Bore Size (mm)	Foot	Flange	Double Clevis
12	QL-012	QF-012	QD-012
16	QL-016	QF-016	QD-016
32	QL-032	QF-032	QD-032
40	QL-040	QF-040	QD-040
50	QL-050	QF-050	QD-050

※ In case of ordering foot mountings, please order 2EA foot mounting per 1EA cylinder

Notice

- ※ Production of middle stroke
Minimum 3mm to 1mm middle stroke production is available by means of mountings spacer at standard stroke cylinder.
ex) AQ2B12-27D inserts 3mm wide spacer in standard cylinder AQ2B12-30D
ex) AQ2B12-29D inserts 21mm wide spacer in standard cylinder AQ2B12-50D

- ACP
- APM
- AS
- AX
- AM2
- AM
- AL
ALX
- AQ
ADQ
- AQ2
ADQ2**
- AJ
AJM
- ABK
- ACK1
- NSK
- AG
- NGQ
- AGX
GX
- NP
- ADR
- AMR
- NDM
- ARD
- NST
- AST
- ASTH
- NLCD
- NLCS

Series AQ2, ADQ2

Notices for products

Please fully understand the notices prior to utilization, and refer to safety notice and common notice.

Warning

Assembly/Disassembly of Snap Ring

- Please use proper flyer (Attached tool of C-type snap ring) for assembly / disassembly.
- Please be cautious all the time that there is a possible damage to human body or vicinity equipments owing to projection of snap ring at the end of wrench (C-type snap ring) in spite of using proper flyer (Attached tool of C-type snap ring). Moreover, after checking full connection of snap ring during attachment, supply air.

Mounting

- Loading removing should be carried out with fixing load side piston rod 2 face width part.
- If load-side piston rod is not firmly fixed, connecting part (screw fixing part) of piston rod is possibly released.

Options

		Bore Size(mm)						
		12	16	25	32	40	50	
Air	Attachment	Through Hole (Standard)	○	○	○	○	○	○
		Both end Tap	○	○	○	○	○	○
Pressure	Piping Method	Magnetic Built-In	○	○	○	○	○	○
		Thread Type	M5×0.8			M5×0.8 ^(mm) Rc(PT)1/8	Rc(PT)1/4	Rc(PT)1/4
Type	Rod end Male Thread		○	○	○	○	○	○
		Rubber Cushion Attached	○	○	○	○	○	○

(Note 1) When requiring style without auto switch, M5×0.8 for 5mm stroke only

Specifications

Type	Air Pressure (non-lubrication) Type
Applied Fluid	Air
Guaranteed Pressure Resistance	1.5MPa{15.3kgf/cm ² }
Maximum Pressure Applied	1.0MPa{9.9kgf/cm ² }
Ambient and Applied Fluid Temperature	-10℃~70℃(No Frozen)
Rod end Thread Tolerance	KS Class 2
Stroke Tolerance	+1.0 0
Piston Speed	50~500mm/s
Rubber Cushion	None
Rod end Thread	Female Thread
Mounting	Through Hole

Minimum Operation Pressure

(Unit : MPa)

Bore Size(mm)	12	16	25	32	40	50
Air Pressure (non-lubrication) Type	0.07	0.07	0.15	0.17	0.15	0.13

Weight Table

(Unit : g)

Operation Method	Bore Size (mm)	Cylinder Stroke (mm)	
		5	10
Forward Type	12	40	47
	16	61	72
	25	118	139
	32	157	181
	40	276	298
	50	-	413
Backward Type	12	46	53
	16	66	78
	25	124	143

Option Weights

(Unit : g)

Bore Size(mm)	12	16	25	32	40	80
Attachment Both End Tap Type	1	2	7	7	6	7
Rod End Male Thread Part	1.5	3	12	26	27	53
Male Thread Nut	1	2	8	17	17	32
Rear Boss Mount	0.7	1.3	3	5	7	13
Rubber Cushion Attached	1	2	4	4	6	10

Calculation Method

ex) AQ2A25-10SM

- Standard Weight : AQ2B25-10S139g
- Extra Weight : Attachment both end tap type7g
- Rod end male thread20g
- Rubber cushion attached4g

170g

Series AQ2, ADQ2

Construction/Parts List

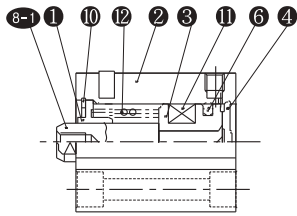

Forward Type

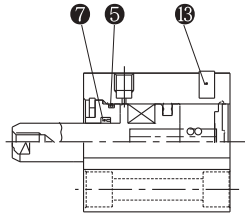

Backward Type

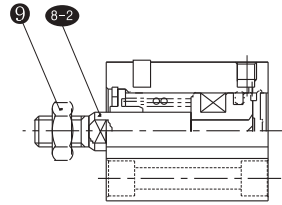

Rod End Male Screw

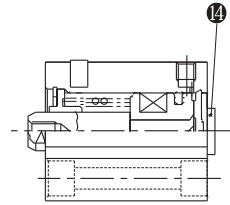

Rear Boss Mount

Parts List

No	Item Name	Quantity	Material	Remark
1	Rod Cover	1	Aluminum alloy	Hard Alumite
2	Cylinder Tube	1	Aluminum alloy	
3	Piston	1	Aluminum alloy	Chromite
4	End Plate	1	Aluminum alloy	Hard Alumite
5	Gasket	1	NBR	
6	Piston Packing	1	NBR	
7	Rod Packing	1	NBR	
8-1	Piston Rod	1	Stainless Steel	Female Screw Type
8-2	Piston Rod	1	Stainless Steel	Male Screw Type
9	Rod End Nut	1	Steel	Zinc White Galvanizing
10	Snap Ring	1	Carbon Tool Steel	Black Coloring
11	Magnet	1	NBR+Ba Ferrite	
12	Return Spring	1	Spring Steel	
13	Air Exhaust bolt	1	Steel	Chromite
14	Nut Ring	1	Aluminum alloy	Hard Alumite

※ In case of Ø12 and Ø16, divided to piston and piston-B.
 ※ In case of Ø12 and Ø16, head side nut and end plate do not exist.
 ※ Copper free is basic.

Seal Kits/Exchanging Parts/Air Pressure (non-lubrication) Type

NO	Item Name	Material	Ø12	Ø16	Ø25	Ø32	Ø40	Ø50
5	GASKET	NBR	C10	C14	C22	C29	C36	C46
6	PISTON PACKING	NBR	PSD-12	PSD-16	PSD-25	PPD-32	PPD-40	PPD-50
7	ROD PACKING	NBR	DYR-6K	DYR-8K	DYR-12	DYR-16	PDU-16Z	PDU-20Z

Theoretical Force

(Unit : N)

Operation Method	Bore Size (mm)	Applied Pressure(MPa)			Spring Restoration		Rod End Allowance Attached Max When Horizontal Load
		0.3	0.5	0.7	Start	End	
Forward Type	12	7	19	28	4	2	3.1
	16	26	57	79	10	4	3.3
	25	188	265	387	19	12	6.6
	32	217	378	593	24	15	17.4
	40	347	598	850	30	13	17.4
	50	535	928	1,316	54	25	30.4
Backward Type	12	5	11	15	10	2	3.1
	16	18	35	55	16	7	3.3
	25	121	187	289	27	9	6.6

1N = 0.102kgf
 1MPa = 10.2kgf/cm²

- ACP
- APM
- AS
- AX
- AM2
- AM
- AL
- ALX
- AQ
- ADQ
- AQ2**
- ADQ2**
- AJ
- AJM
- ABK
- ACK1
- NSK
- AG
- NGQ
- AGX
- GX
- NP
- ADR
- AMR
- NDM
- ARD
- NST
- AST
- ASTH
- NLCD
- NLCS

Series AQ2, ADQ2

Standard Type (Through Hole Type)/AQ2B, ADQ2B-Single Acting Extension Type

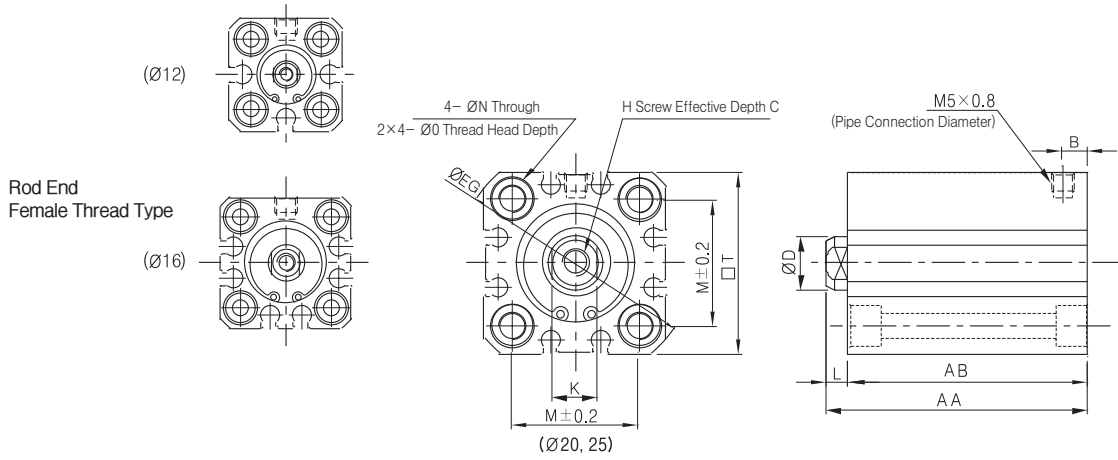

Rod End Male Thread Type

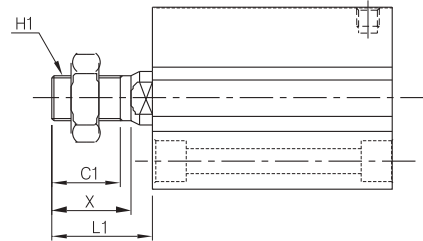

Rod End Male Thread Type (Unit : mm)

Bore Size	L1	C1	H1	X
12	14	9	M5×0.8	10.5
16	15.5	10	M6×1.0	12
25	22.5	15	M10×1.25	17.5

Rear Boss Mount Type (Unit : mm)

Bore Size	G	ØTh9
25	2	15 ⁰ _{-0.043}

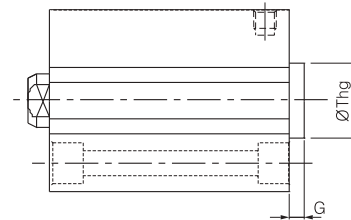

Standard Type (Unit : mm)

Bore Size	Range of Stroke	No Auto Switch					Auto Switch Exists					L	D	N	K	ØEG	M
		AA		AB		B	AA		AB		B						
		5 st	10 st	5 st	10 st		5 st	10 st	5 st	10 st							
12	5, 10	25.5	30.5	22	27	5	36.5	41.5	33	38	6.5	3.5	6	3.5	5	32	15.5
16		27	32	23.5	28.5	5.5	39	44	30.5	35.5	5.5	3.5	8	3.5	6	38	20
25		32.5	37.5	27.5	32.5	5.5	42.5	47.5	37.5	42.5	5.5	5	12	5.5	10	52	28

Bore Size	□T	H	C	O
12	25	M3×0.5	6	6.5 Depth 4
16	29	M4×0.7	8	6.5 Depth 4
25	40	M6×1.0	12	9 Depth 7

* If auto switch does not exist, Ø12-5 stroke, Ø25-5/10 stroke has penetrated both ends for attachment bolt of tube.

* For both ends tap type, refer to p.333

Series AQ2, ADQ2

AQ2-Single Acting Extension Type(Ø32~50)

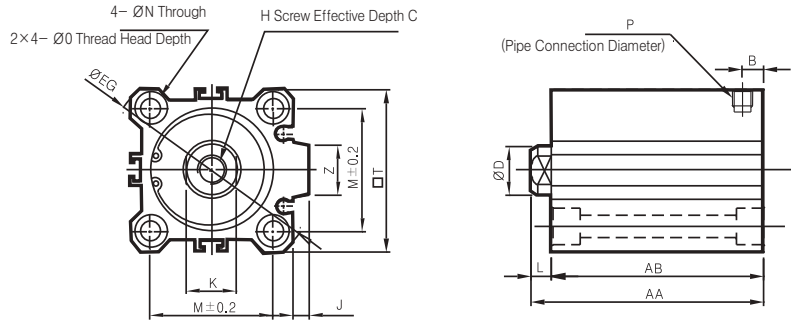

Rod End Male Thread Type

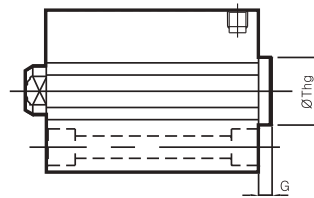
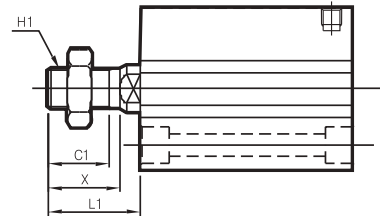

Rod End Male Thread Type (Unit : mm)

Bore Size	L1	C1	H1	X
32	28.5	20.5	M14×1.5	23.5
40	28.5	20.5	M14×1.5	23.5
50	33.5	26	M18×1.25	28.5

Rear Boss Mount Type (Unit : mm)

Bore Size	G	ØTh9
32	2	21 ⁰ _{-0.052}
40	2	28 ⁰ _{-0.052}
50	2	35 ⁰ _{-0.052}

Standard Type (Unit : mm)

Bore Size	No Auto Switch					Auto Switch Exists				B	L	D	N	K	ØEG	M
	AA		AB		B	AA		AB								
	5 st	10 st	5 st	10 st		5 st	10 st	5 st	10 st							
32	35	40	28	33	7.5	45	50	38	43	7.5	7	16	5.5	14	60	34
40	41.5	46.5	34.5	39.5	8	51.5	56.5	44.5	49.5	8	7	16	5.5	14	69	40
50	-	48.5	-	40.5	10.5	-	58.5	-	50.5	10.5	8	20	6.6	17	86	50

Bore Size	□T	H	C	O	J	P	Z
32	45	M8×1.25	13	9 Depth 7	4.5	Rc 1/8	18
40	52	M8×1.25	13	9 Depth 7	5	Rc 1/8	18
50	64	M10×1.5	15	11 Depth 8	7	Rc 1/4	22

- ACP
- APM
- AS
- AX
- AM2
- AM
- AL
- ALX
- AQ
- ADQ
- AQ2**
- ADQ2**
- AJ
- AJM
- ABK
- ACK1
- NSK
- AG
- NGQ
- AGX
- GX
- NP
- ADR
- AMR
- NDM
- ARD
- NST
- AST
- ASTH
- NLCD
- NLCS

Series AQ2, ADQ2

Standard Type (Through Hole Type)/AQ2B, ADQ2B – Single Acting Retraction Type

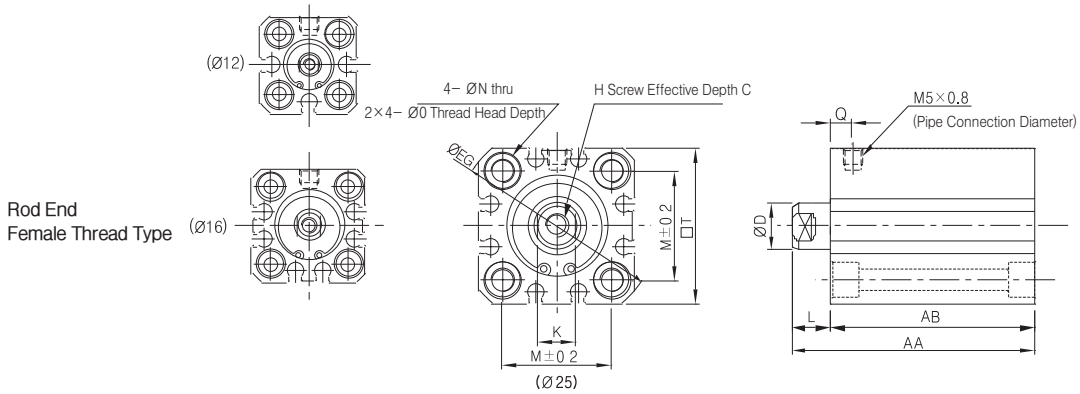

Rod End Male Thread Type

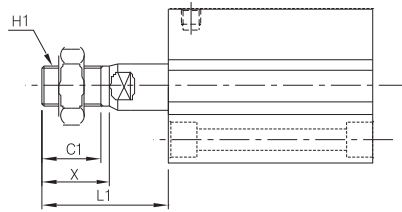

Rod End Male Thread Type

(Unit : mm)

Bore Size	L1		C1	H1	X
	5 st	10 st			
12	19	24	9	M5×0.8	10.5
16	20.5	25.5	10	M6×1.0	12
25	27.5	32.5	15	M10×1.25	17.5

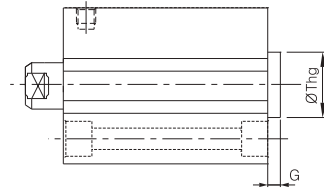

Rear Boss Mount Type

(Unit : mm)

Bore Size	G	ØTh9
25	2	15 ⁰ _{-0.043}

Standard Type

(Unit : mm)

Bore Size	Range of Stroke	No Auto Switch					Auto Switch Exists					L		D	N	K	ØEG	M	□T	C	H	O
		AA		AB		Q	AA		AB		Q	5 st	10 st									
		5 st	10 st	5 st	10 st		5 st	10 st	5 st	10 st												
12	5, 10	30.5	40.5	22	27	7.5	41.5	51.5	33	38	11	8.5	13.5	6	3.5	5	32	15.5	25	6	M3×0.5	6.5 Depth 4
16		32	42	23.5	28.5	8	44	54	35.5	40.5	11	8.5	13.5	8	3.5	6	38	20	29	8	M4×0.7	6.5 Depth 4
25		37.5	47.5	27.5	32.5	11	47.5	57.5	37.5	42.5	11	10	15	12	5.5	10	52	28	40	12	M6×1.0	9 Depth 7

※ If auto switch does not exist, Ø12-5 stroke, Ø25-5/10 stroke has penetrated both ends for attachment bolt of tube.
 ※ For both ends tap type, refer to p.333

Series AQ2, ADQ2

Foot Type/A(D)Q2L

① Ø12~Ø16

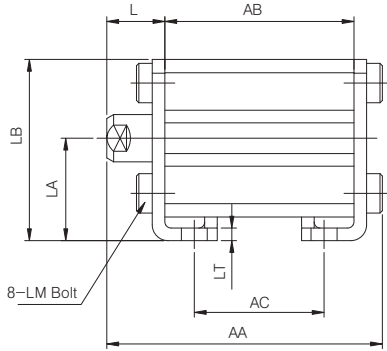

② Ø32, Ø40, Ø50

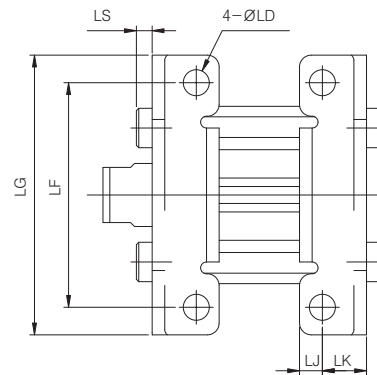
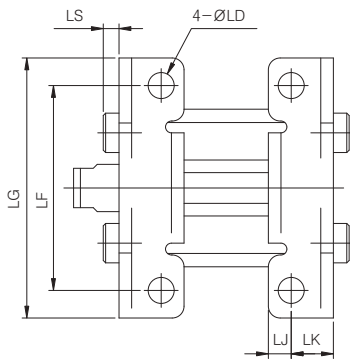
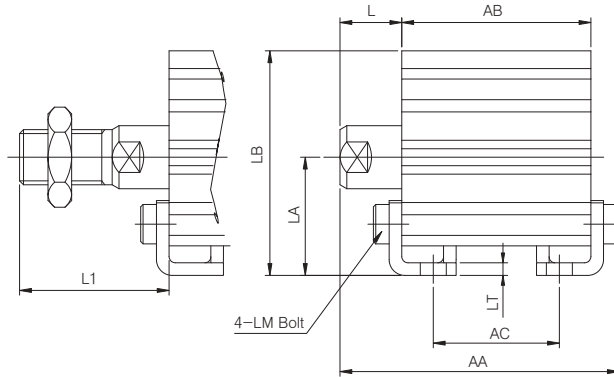

- ACP
- APM
- AS
- AX
- AM2
- AM
- AL
ALX
- AQ
ADQ
- AQ2
ADQ2
- AJ
AJM
- ABK
- ACK1
- NSK
- AG
- NGQ
- AGX
GX
- NP
- ADR
- AMR
- NDM
- ARD
- NST
- AST
- ASTH
- NLCD
- NLCS

Material : Carbon Steel

(Unit : mm)

Bore Size (Ø)	Standard Stroke	No Auto Switch			Auto Switch Exists			L	L1	LA	LB	LD	LF	LG	LJ	LM	LK	LS	LT
		AA	AB	AC	AA	AB	AC												
12	5	40.3	22	10	51.3	33	21	13.5	24	17	29.5	4.5	34	44	4.5	M4×0.7	8	2.8	2
	10	45.3	27	15	56.3	38	26												
16	5	41.8	23.5	11.5	53.8	35.5	23.5	13.5	25.5	19	33.5	4.5	38	48	5	M4×0.7	8	2.8	2
	10	46.8	28.5	16.5	58.8	40.5	28.5												
25	5	49.7	27.5	12.5	59.7	37.5	22.5	15	32.5	26	46	6.6	52	66	5.8	M6×1.0	10.7	4	3.2
	10	54.7	32.5	17.5	64.7	42.5	27.5												
32	5	52.2	28	12	62.2	38	22	17	38.5	30	57	6.6	57	71	5.8	M6×1.0	11.2	4	3.2
	10	57.2	33	17	67.2	43	27												
40	5	58.7	34.5	18.5	68.7	44.5	28.5	17	38.5	33	64	6.6	64	78	7	M6×1.0	11.2	4	3.2
	10	63.7	39.5	23.5	73.7	49.5	33.5												
50	10	66.7	40.5	17.5	76.7	50.5	27.5	18	43.5	39	78	9	79	95	8	M8×1.25	14.7	5	3.2

※ In case of mounting attached cylinder, A-type tube is standard.
 ※ Indication and dimension are same as dimension of standard cylinder.
 ※ Cylinder and foot are delivered without assembly.

Series AQ2, ADQ2

Rod Side Flange Type/A(D)Q2F

① Ø12, Ø16, Ø25

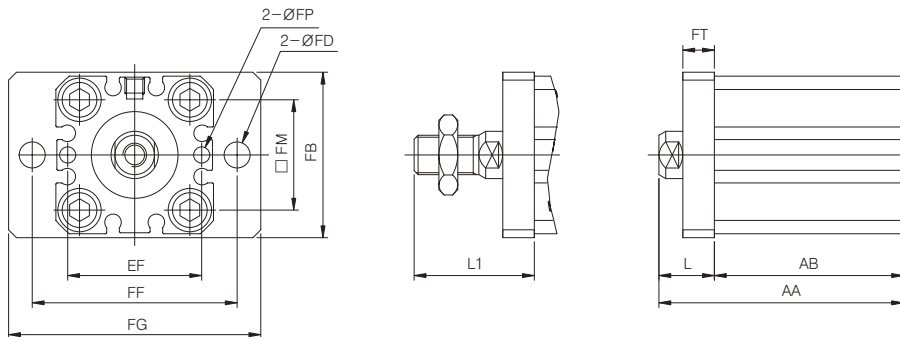

② Ø32, Ø40, Ø50

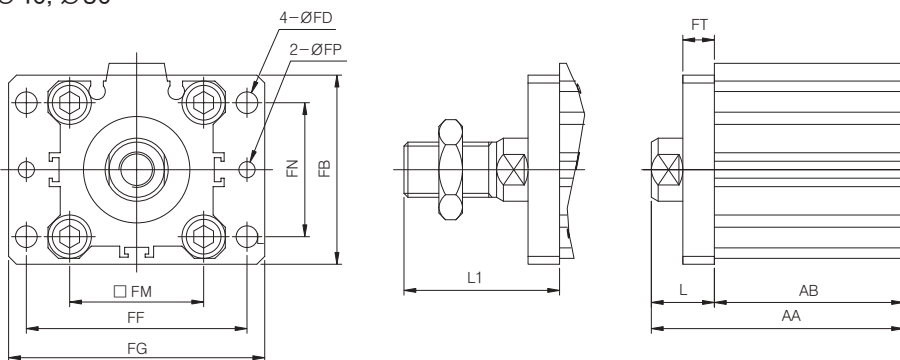

Material : Carbon Steel

(Unit : mm)

Bore Size (Ø)	Standard Stroke	No Auto Switch		Auto Switch Exists		L	L1	FB	FD	FP	FE	FF	FG	FM	FN	FT
		AA	AB	AA	AB											
12	5	35.5	22	46.5	33	13.5	24	25	4.5	3.1	23	45	55	15.5	-	5.5
	10	40.5	27	51.5	38											
16	5	37	23.5	49	35.5	13.5	25.5	30	4.5	3.1	24	45	55	20	-	5.5
	10	42	28.5	54	40.5											
25	5	42.5	27.5	52.5	37.5	15	32.5	42	6.6	4.1	34	52	64	28	-	8
	10	47.5	32.5	57.5	42.5											
32	5	45	28	55	38	17	38.5	48	5.5	4.1	-	56	65	34	34	8
	10	50	33	60	43											
40	5	51.5	34.5	61.5	44.5	17	38.5	54	5.5	4.1	-	62	72	40	40	8
	10	56.5	39.5	66.5	49.5											
50	10	58.5	40.5	68.5	50.5	18	43.5	67	6.6	5.1	-	76	89	50	50	9

※ In case of mounting attached cylinder, A-type tube is standard.
 ※ Indication and dimension are same as dimension of standard cylinder.
 ※ Cylinder and foot are delivered without assembly.

Series AQ2, ADQ2

Head Side Flange Type/A(D)Q2G

① Ø12, Ø16, Ø25

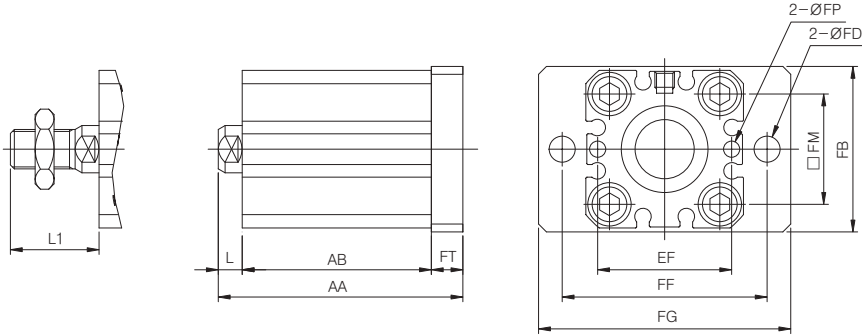

② Ø32, Ø40, Ø50

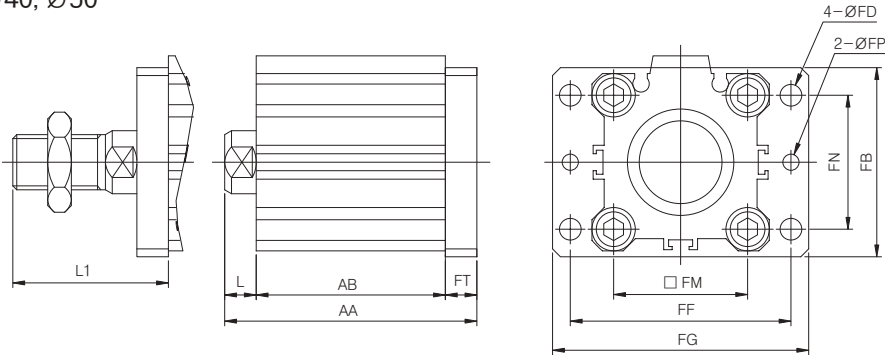

- ACP
- APM
- AS
- AX
- AM2
- AM
- AL
- ALX
- AQ
- ADQ
- AQ2**
- ADQ2**
- AJ
- AJM
- ABK
- ACK1
- NSK
- AG
- NGQ
- AGX
- GX
- NP
- ADR
- AMR
- NDM
- ARD
- NST
- AST
- ASTH
- NLCD
- NLCS

Material : Carbon Steel

(Unit : mm)

Bore Size (Ø)	Standard Stroke	No Auto Switch		Auto Switch Exists		L	L1	FB	FD	FP	FE	FF	FG	FM	FN	FT
		AA	AB	AA	AB											
12	5	31	22	42	33	3.5	14	25	4.5	3.1	45	23	55	15.5	-	5.5
	10	36	27	47	38											
16	5	32.5	23.5	44.5	35.5	3.5	15.5	30	4.5	3.1	45	24	55	20	-	5.5
	10	37.5	28.5	49.5	40.5											
25	5	40.5	27.5	50.5	37.5	5	22.5	42	6.6	4.1	52	34	64	28	-	8
	10	45.5	32.5	55.5	42.5											
32	5	43	28	53	38	7	28.5	48	5.5	4.1	-	56	65	34	34	8
	10	48	33	58	43											
40	5	49.5	34.5	59.5	44.5	7	28.5	54	5.5	4.1	-	62	72	40	40	8
	10	54.5	39.5	64.5	49.5											
50	10	57.5	40.5	67.5	50.5	8	33.5	67	6.6	5.1	-	76	89	50	50	9

※ In case of mounting attached cylinder, A-type tube is standard.
 ※ Indication and dimension are same as dimension of standard cylinder.
 ※ Cylinder and foot are delivered without assembly.

Series AQ2, ADQ2

Double Clevis Type/A(D)Q2D

Ø12~Ø25

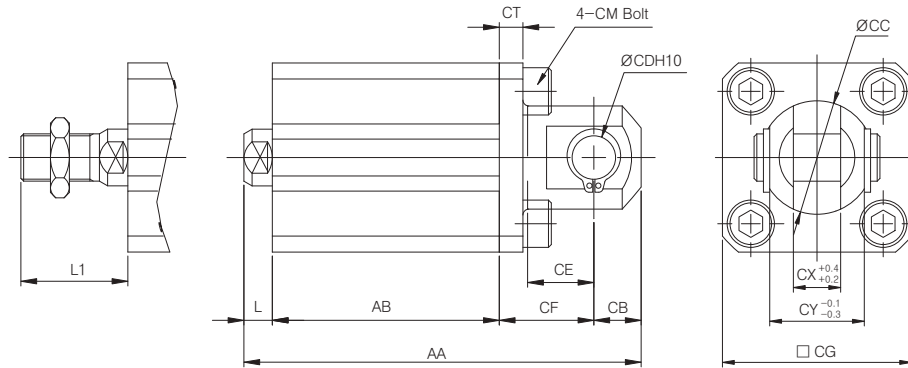

Ø32~Ø100

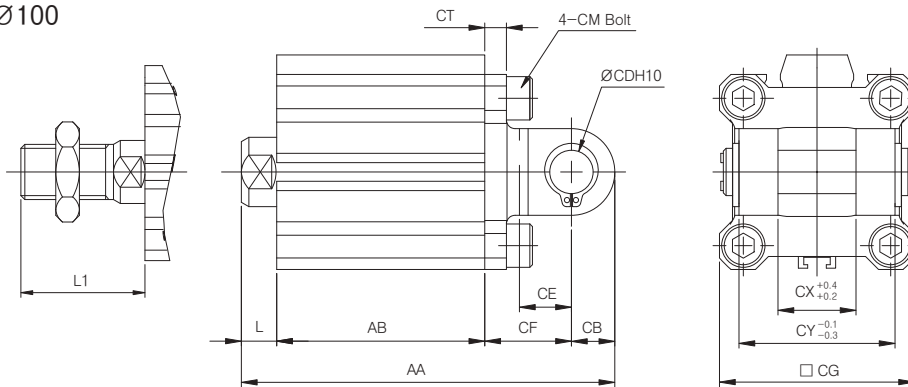

Material I: Ø12~Ø16-Carbon Steel, Ø32~Ø50-Cast Iron

(Unit : mm)

Bore Size (Ø)	Standard Stroke	No Auto Switch		Auto Switch Exists		L	L1	CB	CE	CF	CG	CM	CD	CT	CX	CY	CC (Ø)
		AA	AB	AA	AB												
12	5	45.5	22	56.5	33	3.5	14	6	7	14	25	M4×0.7	5 ^{+0.05} ₀	4	5	10	12
	10	50.5	27	61.5	38												
16	5	48	23.5	60	35.5	3.5	15.5	6	10	15	29	M4×0.7	5 ^{+0.05} ₀	4	6.5	12	14
	10	53	28.5	65	40.5												
25	5	62.5	27.5	72.5	37.5	5	22.5	10	14	20	40	M6×1.0	10 ^{+0.06} ₀	5	10	20	-
	10	67.5	32.5	77.5	42.5												
32	5	65	28	75	38	7	28.5	10	14	20	45	M6×1.0	10 ^{+0.06} ₀	5	18	36	-
	10	70	33	80	43												
40	5	73.5	34.5	83.5	44.5	7	28.5	10	14	22	52	M6×1.0	10 ^{+0.06} ₀	6	18	36	-
	10	78.5	39.5	88.5	49.5												
50	10	90.5	40.5	100.5	50.5	8	33.5	14	20	28	64	M8×1.25	14 ^{+0.07} ₀	7	22	44	-

- * In case of mounting attached cylinder, A-type tube is standard.
- * Indication and dimension are same as dimension of standard cylinder.
- * Cylinder and foot are delivered without assembly.

Series AQ2, ADQ2

Foot Type/A(D)Q2L

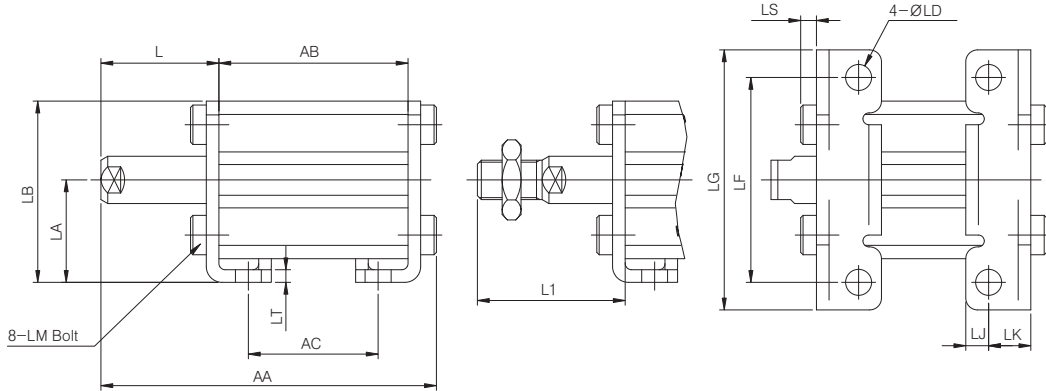

Material : Carbon Steel

(Unit : mm)

Bore Size (Ø)	Standard Stroke	No Auto Switch			Auto Switch Exists			L	L1	LA	LB	LD	LF	LG	LJ	LM	LK	LS	LT
		AA	AB	AC	AA	AB	AC												
12	5	45.3	22	10	56.3	33	21	18.5	29	17	29.5	4.5	34	44	4.5	M4×0.7	8	2.8	2
	10	55.3	27	15	66.3	38	26	23.5	34										
16	5	46.8	23.5	11.5	58.8	35.5	23.5	18.5	30.5	19	33.5	4.5	38	48	5	M4×0.7	8	2.8	2
	10	56.8	28.5	16.5	68.8	40.5	28.5	23.5	35.5										
25	5	54.7	27.5	12.5	64.7	37.5	22.5	20	37.5	26	46	6.6	52	66	5.8	M6×1.0	10.7	4	3.2
	10	64.7	32.5	17.5	74.7	42.5	27.5	25	42.5										

- * In case of mounting attached cylinder, A-type tube is standard.
- * Indication and dimension are same as dimension of standard cylinder.
- * Cylinder and foot are delivered without assembly.

- ACP
- APM
- AS
- AX
- AM2
- AM
- AL
- ALX
- AQ
- ADQ
- AQ2**
- ADQ2**
- AJ
- AJM
- ABK
- ACK1
- NSK
- AG
- NGQ
- AGX
- GX
- NP
- ADR
- AMR
- NDM
- ARD
- NST
- AST
- ASTH
- NLCD
- NLCS

Series AQ2, ADQ2

Rod Side Flange Type/A(D)Q2F

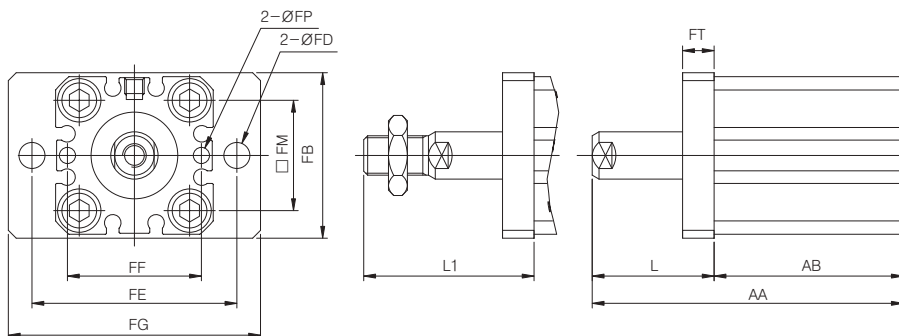

Material : Carbon Steel

(Unit : mm)

Bore Size (Ø)	Standard Stroke	No Auto Switch		Auto Switch Exists		L	L1	FB	FD	FP	FE	FF	FG	FM	FT
		AA	AB	AA	AB										
12	5	40.5	22	51.5	33	18.5	29	25	4.5	3.1	45	23	55	15.5	5.5
	10	50.5	27	61.5	38	23.5	34								
16	5	42	23.5	54	35.5	18.5	30.5	30	4.5	3.1	45	24	55	20	5.5
	10	52	28.5	64	40.5	23.5	35.5								
25	5	47.5	27.5	57.5	37.5	20	37.5	42	6.6	4.1	52	34	64	28	8
	10	57.5	32.5	67.5	42.5	25	42.5								

- ※ In case of mounting attached cylinder, A-type tube is standard.
- ※ Indication and dimension are same as dimension of standard cylinder.
- ※ Cylinder and foot are delivered without assembly.

Head Side Flange Type/A(D)Q2G

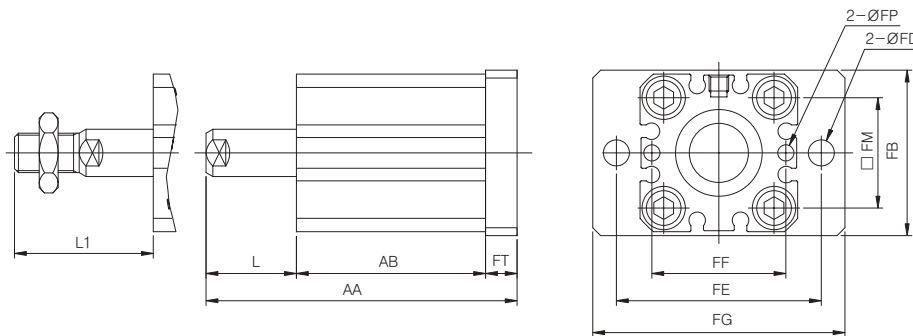

Material : Carbon Steel

(Unit : mm)

Bore Size (Ø)	Standard Stroke	No Auto Switch		Auto Switch Exists		L	L1	FB	FD	FP	FE	FF	FG	FM	FT
		AA	AB	AA	AB										
12	5	36	22	47	33	8.5	19	25	4.5	3.1	45	23	55	15.5	5.5
	10	46	27	57	38	13.5	24								
16	5	37.5	23.5	49.5	35.5	8.5	20.5	30	4.5	3.1	45	24	55	20	5.5
	10	47.5	28.5	59.5	40.5	13.5	25.5								
25	5	45.5	27.5	55.5	37.5	10	27.5	42	6.6	4.1	52	34	64	28	8
	10	55.5	32.5	65.5	42.5	15	32.5								

- ※ In case of mounting attached cylinder, A-type tube is standard.
- ※ Indication and dimension are same as dimension of standard cylinder.
- ※ Cylinder and foot are delivered without assembly.

Series AQ2, ADQ2

Double Clevis Type/A(D)Q2D

Ø12~Ø25

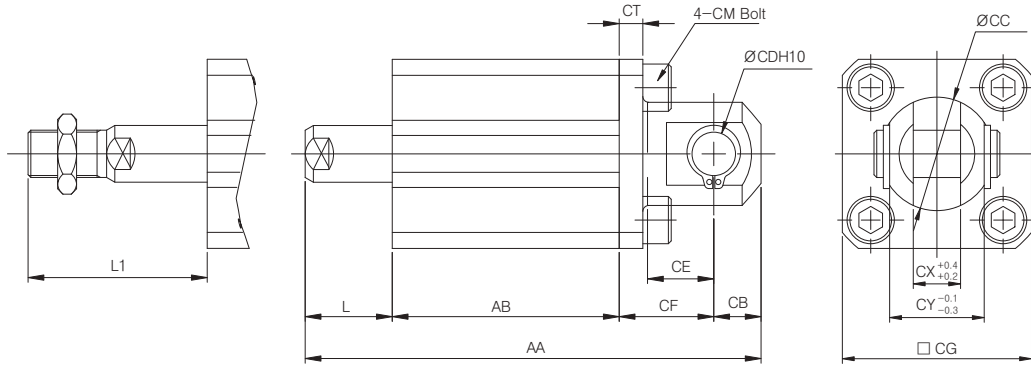

Ø32~Ø100

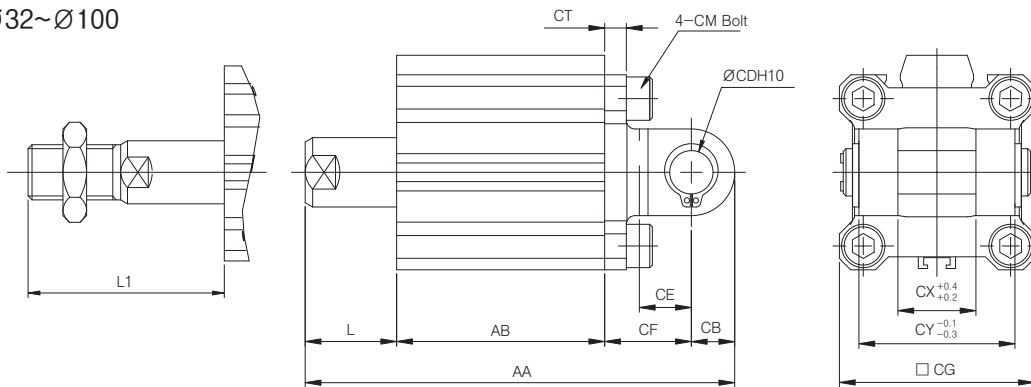

- ACP
- APM
- AS
- AX
- AM2
- AM
- AL
ALX
- AQ
ADQ
- AQ2
ADQ2**
- AJ
AJM
- ABK
- ACK1
- NSK
- AG
- NGQ
- AGX
GX
- NP
- ADR
- AMR
- NDM
- ARD
- NST
- AST
- ASTH
- NLCD
- NLCS

Material: Ø12~Ø16-Carbon Steel, Ø32~Ø50-Cast Iron

(Unit : mm)

Bore Size (Ø)	Standard Stroke	No Auto Switch		Auto Switch Exists		L	L1	CB	CE	CF	CG	CM	CD	CT	CX	CY	CC (Ø)	
		AA	AB	AA	AB													
12	5	50.5	22	61.5	33	8.5	19	6	7	14	25	M4×0.7	5	+0.05 0	4	5	10	12
	10	60.5	27	71.5	38	13.5	24											
16	5	53	23.5	65	35.5	8.5	20.5	6	10	15	29	M4×0.7	5	+0.05 0	4	6.5	12	14
	10	63	28.5	75	40.5	13.5	25.5											
25	5	67.5	27.5	77.5	37.5	10	27.5	10	14	20	40	M6×1.0	10	+0.06 0	5	10	20	24
	10	77.5	32.5	87.5	42.5	15	32.5											

- ※ In case of mounting attached cylinder, A-type tube is standard.
- ※ Indication and dimension are same as dimension of standard cylinder.
- ※ Cylinder and foot are delivered without assembly.

Series AQ2K, ADQ2K

Non-Rotation Rod Type/Double Acting : Single Rod

Bore Size(mm) : Ø32, Ø40, Ø50, Ø63

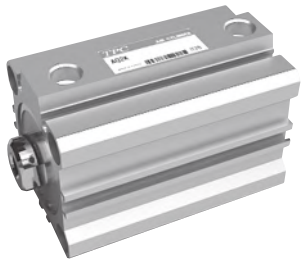

- NON ROD ROTATION COMPACT CYLINDER
- SPACE SAVING CYLINDER
- COMPACT EQUIPMENT DESIGN AVAILABLE

Symbol

Non Rod Rotation Type

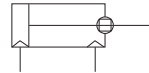

How to Order

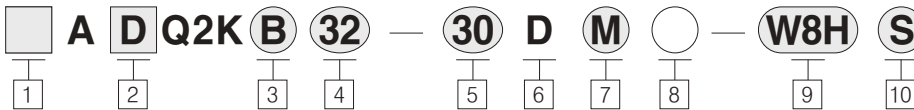

1 Magnet
Blank : Rc(PT)
U : NPT

2 Magnet
Blank : None
D : Built-in magnet

3 Attachment
B : Through hole (standard type)
A : Both end tap
D : Double clevis (standard both end type)
F : Rod side flange (standard both end type)
G : Head side flange (standard both end type)
L : Foot (standard both end type)
* Mountings are delivered without assembly

4 Bore Size
32 : 32mm(1¼Nom.)
40 : 40mm(1½Nom.)
50 : 50mm(2Nom.)
63 : 63mm(2½Nom.)

5 Stroke(mm)
Bore Size Standard Stroke
Ø32, 40 : 5,10,15,20,25,30,35,40,45,50,75,100
Ø50, 63 : 10,15,20,25,30,35,40,45,50,75,100

6 Action
D : Double Acting Type

7 Body Option
Blank : Standard type
(Rod end female thread)

M : Rod end male thread
F : Rear boss mount
I : Single knuckle joint (rod end male thread)
Y : Double Knuckle Joint (rod end male thread)
* Possible to combine body specification (FM, FI, FY)
* I and Y are delivered without assembly

8 Series
Blank : Standard type
XC16 : Copper-free
* Ø32~Ø40 : XC16 is standard type

9 Auto Switch
Blank : None
Reed switch
W4 : W4 (Ø32~Ø100)
W8HV : Subcompact auto switch horizontal (vertical) type, 2 wire type
Non contact point existing auto switch
W9HV : Subcompact auto switch horizontal (vertical) type, 2 wire type
W9HVN : Subcompact auto switch horizontal (vertical) type, 3 wire type
W2PL : Ø50~Ø100
* In case of 3m lead wire, L should be added at the end of item number
ex) W4L or W2PL
* In case of 5m lead wire, please contact us

10 Number of Auto Switches
Blank : 2 pcs
S : 1 pc
N : N pcs

Item Number of Mountings

Bore Size (mm)	Foot	Flange	Double Clevis
32	QL-032	QF-032	QD-032
40	QL-040	QF-040	QD-040
50	QL-050	QF-050	QD-050
63	QL-063	QF-063	QD-063

* In case of ordering foot mounting, please order 2EA foot mountings per 1EA cylinder

● Notice

* **Production of middle stroke**
Minimum 3mm to 1mm middle stroke production is available by means of mountings spacer at standard stroke cylinder.
ex) AQ2B12-27D inserts 3mm wide spacer in standard cylinder AQ2B12-30D
ex) AQ2B12-29D inserts 21mm wide spacer in standard cylinder AQ2B12-50D

Series AQ2K, ADQ2K

Notices for products

Please fully understand the notices prior to utilization, and refer to safety notice and common notice.

Warning

Assembly/Disassembly of Snap Ring

- Please use proper flyer (Attached tool of C-type snap ring) for assembly / disassembly.
- Please be cautious all the time that there is a possible damage to human body or vicinity equipments owing to projection of snap ring at the end of flyer (C-type snap ring) in spite of using proper flyer (Attached tool of C-type snap ring). Moreover, after checking full connection of snap ring during attachment, supply air.

Attachment

- Loading removing should be carried out with fixing load-side piston rod 2 face width part.
- If load-side piston rod is not firmly fixed, connection part (screw fixing part) of piston rod is possibly released.



- Please be careful not to allow rotation torque to piston rod during utilization of rod rotation protecting cylinder, otherwise, which may amplify non-rotating level owing to deformation of rotation protecting guide. Allowance of rotating torque follows the table below.

Rotation Allowable Torque	32	40	50	63
kgf • cm or Less	4.5	4.5	4.5	4.5

- Please always use with shaft direction since load of piston rod is in shaft direction.

Options

		Bore Size(mm)	32	40	50	63
Air Pressure Type	Attachment	Through Hole (Standard)	○	○	○	○
		Both ends Tap	-	○	○	○
	Magnetic Built-In		○	○	○	○
	Piping Method	Thread Type	^{Note1)} M5×0.8 Rc(PT) 1/8	Rc(PT) 1/8	Rc(PT) 1/4	Rc(PT) 1/4
			Rod end Male-Thread	○	○	○
	Rear Boss Mount		○	○	○	○

(Note1) When requiring without auto switch, M5×0.8 for 5mm stroke only

Specifications

Type	Air Pressure (non-lubrication) Type
Applied Fluid	Air
Guaranteed Pressure Resistance	1.5MPa{15.3kgf/cm ² }
Maximum Pressure Applied	1.0MPa{9.9kgf/cm ² }
Ambient and Applied Fluid Temperature	-10℃~+70℃(No Frozen)
Rod end Thread Tolerance	KS Class 2
Stroke Tolerance	^{+1.0} ₀
Piston Speed	50~500mm/s
Rubber Cushion	None
Rod end Screw	Female Thread
Mount	Through Hole

Minimum Operation Pressure (Unit : MPa)

Bore Size(mm)	32	40	50	63
Air Pressure (non-lubrication) Type	0.05	0.05	0.05	0.05

Rod Rotation Preventing Specification

Bore Size(mm)	32	40	50	63
Rod Rotation Protecting Level	±0.8°			

- ACP
- APM
- AS
- AX
- AM2
- AM
- AL ALX
- AQ ADQ
- AQ2 ADQ2**
- AJ AJM
- ABK
- ACK1
- NSK
- AG
- NGQ
- AGX GX
- NP
- ADR
- AMR
- NDM
- ARD
- NST
- AST
- ASTH
- NLCD
- NLCS

Series AQ2K, ADQ2K

Theoretical Output Sheet (Unit : N)



Bore Size (mm)	Operation direction	Applied Pressure (MPa)		
		0.3	0.5	0.7
32	IN	181	302	422
	OUT	241	402	563
40	IN	317	528	739
	OUT	377	628	880
50	IN	495	825	1,150
	OUT	589	982	1,370
63	IN	841	1,400	1,960
	OUT	935	1,560	2,180

Weight Sheet (Unit : g)

Bore Size (mm)	Applied Pressure (MPa)											
	5	10	15	20	25	30	35	40	45	50	75	100
32	203	223	243	263	283	303	323	343	363	383	403	-
40	215	238	261	284	307	330	353	376	399	422	445	468
50	-	381	418	455	492	529	566	603	640	677	714	751
63	-	550	592	634	676	718	760	802	844	886	928	970

Extra Weight Sheet (Unit : g)

Bore Size (mm)	20	25	32	40	50	63
Attachment Both End Tap Type	-	-	-	6	7	17
Rod End	Male Thread Part		6	12	26	53
Male Thread	Nut		4	8	17	32
Rear Boss Mount	2	3	5	7	13	25

Calculation Method

ex) ACQ2KA40-20DM

- Standard Weight : ACQ2KB40-20D284g
- Extra Weight : Attachment both end tap type6g
- Rod end male thread44g

334g



Series AQ2K, ADQ2K

Construction/Parts List

Standard Type (Bore $\varnothing 32 \sim \varnothing 63$)

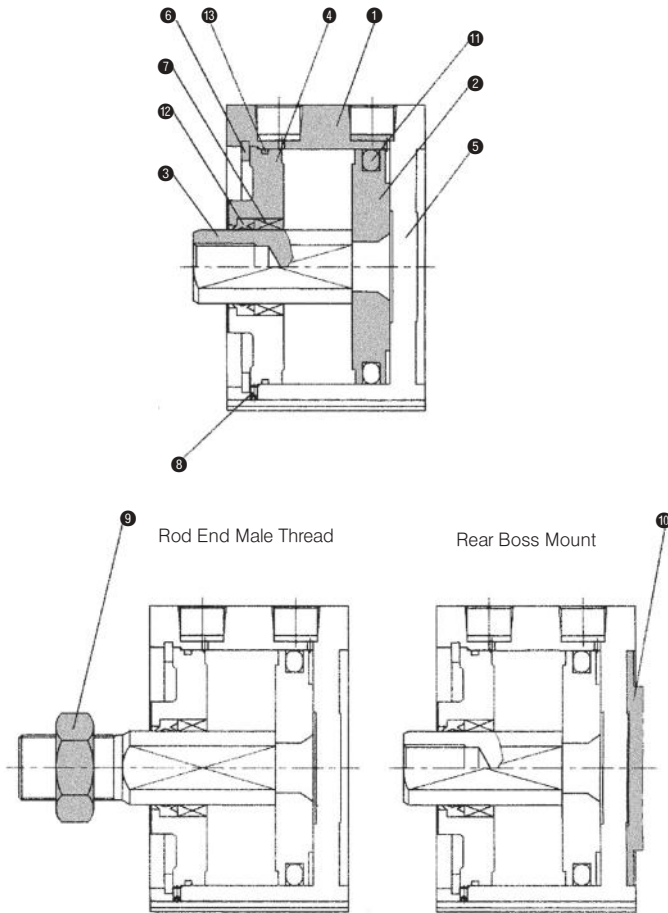

- ACP
- APM
- AS
- AX
- AM2
- AM
- AL
ALX
- AQ
ADQ
- AQ2
ADQ2
- AJ
AJM
- ABK
- ACK1
- NSK
- AG
- NGQ
- AGX
GX
- NP
- ADR
- AMR
- NDM
- ARD
- NST
- AST
- ASTH
- NLCD
- NLCS

Component List

No.	Name of Component	Material	Remark
1	Cylinder Tub	Aluminum Alloy	Hard alumite
2	Piston	Aluminum Alloy	Chromite
3	Piston Rod	Stainless	$\varnothing 32 \sim \varnothing 63$, Hard Chrome Plated
4	Rod Cover	Aluminum Alloy	White Hard Alumite
5	End Plate	Aluminum Alloy	Hard Alumite
6	Stop Ring	Carbon tool Steel	Phosphate Coating
7	Bush	Sintered Contained Alloy	
8	Hexagonal Hole Attached Stop Screw	Alloy Steel	Black Colored
9	Rod End Nut	Carbon Steel	Nickel Alloy

No.	Name of Component	Material	Remark
10	Nut Ring	Aluminum Alloy	Hard Alumite

Seal Kits/Exchanging Parts/Air Pressure (non-lubrication) Type

NO	Item Name	Material	$\varnothing 32$	$\varnothing 40$	$\varnothing 50$	$\varnothing 63$
11	Piston Packing	NBR	PPD-32	PPD-40	PPD-50	PPD-63
12	Rod Packing	NBR	SORA-16	SORA-16	SORA-20	SORA-20
13	Gasket	NBR	C-29	C-36	C-46	C-60

Series AQ2K, ADQ2K

AQ2K/ADQ2K Standard Type (Through Hole Type) / AQ2KB, AQ2KB

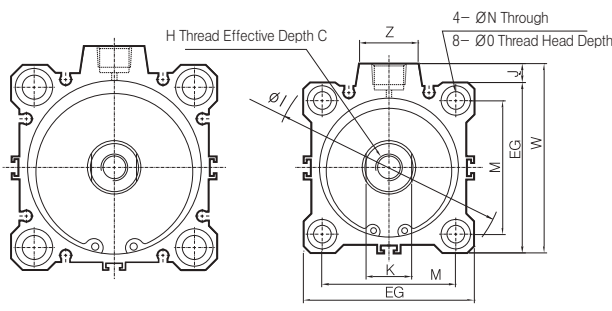

※ In case of Ø63

※ In case of Ø32, 40, 50

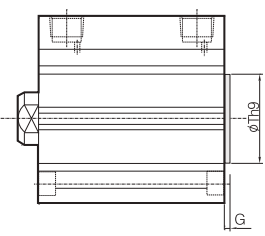
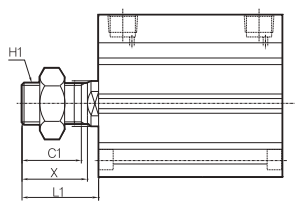
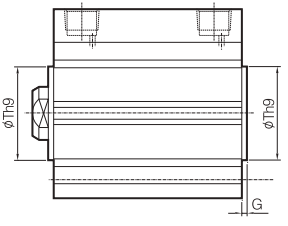
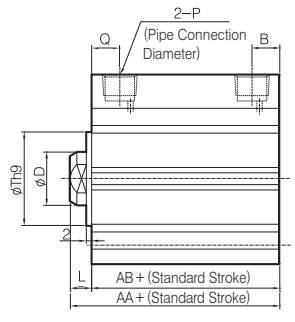

Rod End Male Thread Type (Unit : mm)

Bore Size(mm)	C1	H1	L1	X
Ø32	20.5	M14×1.5	28.5	23.5
Ø40	20.5	M14×1.5	28.5	23.5
Ø50	26	M18×1.5	33.5	28.5
Ø63	26	M18×1.5	33.5	28.5

Rear Boss Mount Type (Unit : mm)

Bore Size(mm)	G	Th9
Ø32	2	21 ⁰ _{-0.052}
Ø40	2	28 ⁰ _{-0.052}
Ø50	2	35 ⁰ _{-0.062}
Ø63	2	35 ⁰ _{-0.062}

Standard Type (Unit : mm)

Bore Size	Range of Standard Stroke	Standard Stroke												C	D	EG	H	I	J	K	M	N	ØO	W	Z	ØTh9
		No Auto Switch						Auto Switch Exists																		
		AA	AB	B	L	P	Q	AA	AB	B	L	P	Q													
Ø32	5	39	32	5.5	7	M5×0.8	20.5	49	42	5.5	7	M5×0.8	20.5	13	16	45	M8×1.25	60	4.5	14	34	5.5	9Depth7	49.5	14	21 ⁰ _{-0.052}
	10~50	49	42	7.5	7	Rc(PT) 1/8	19.5	49	42	7.5	7	Rc(PT)1/8	19.5	13	16	45	M8×1.25	60	4.5	14	34	5.5	9Depth7	49.5	14	21 ⁰ _{-0.052}
	75, 100	47	42	7.5	7	Rc(PT) 1/8	19.5	49	42	7.5	7	Rc(PT)1/8	19.5	13	16	45	M8×1.25	60	4.5	14	34	5.5	9Depth7	49.5	14	21 ⁰ _{-0.052}
Ø40	5~50	37	30	8	7	Rc(PT) 1/8	11	46.5	39.5	8	7	Rc(PT)1/8	11	13	16	52	M8×1.25	69	5	14	40	5.5	9Depth7	57	14	28 ⁰ _{-0.052}
	75, 100	46.5	39.5	8	7	Rc(PT) 1/8	14	46.5	39.5	8	7	Rc(PT)1/8	11	13	16	52	M8×1.25	69	5	14	40	5.5	9Depth7	57	14	28 ⁰ _{-0.052}
	5~50	37	30	8	7	Rc(PT) 1/8	11	46.5	39.5	8	7	Rc(PT)1/8	11	13	16	52	M8×1.25	69	5	14	40	5.5	9Depth7	57	14	28 ⁰ _{-0.052}
Ø50	10~50	38.5	30.5	10.5	8	Rc(PT) 1/4	10.5	48.5	40.5	10.5	8	Rc(PT)1/4	10.5	15	20	64	M10×1.5	87	7	17	50	6.6	11Depth8	71	22	35 ⁰ _{-0.052}
	75, 100	48.5	40.5	10.5	8	Rc(PT) 1/4	14	48.5	40.5	10.5	8	Rc(PT)1/4	10.5	15	20	64	M10×1.5	87	7	17	50	6.6	11Depth8	71	22	35 ⁰ _{-0.052}
	10~50	44	36	10.5	8	Rc(PT) 1/4	15	54	46	10.5	8	Rc(PT)1/4	15	15	20	77	M10×1.5	103	7	17	60	9	14Depth 10.5	84	22	35 ⁰ _{-0.052}
Ø63	10~50	44	36	10.5	8	Rc(PT) 1/4	15	54	46	10.5	8	Rc(PT)1/4	15	15	20	77	M10×1.5	103	7	17	60	9	14Depth 10.5	84	22	35 ⁰ _{-0.052}
	75, 100	54	46	10.5	8	Rc(PT) 1/4	16.5	54	46	10.5	8	Rc(PT)1/4	15	15	20	77	M10×1.5	103	7	17	60	9	14Depth 10.5	84	22	35 ⁰ _{-0.052}



Series AQ2K, ADQ2K

Foot Type/A(D)Q2KL

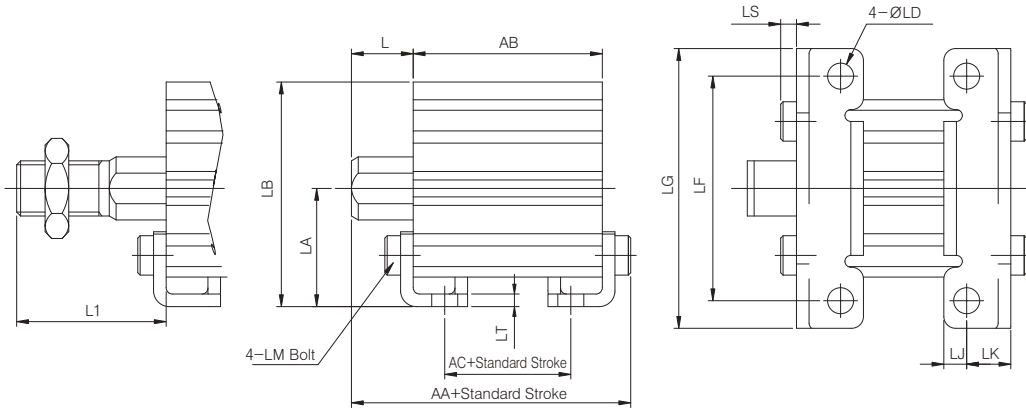

Material : Carbon Steel

(Unit : mm)

Bore Size (Ø)	Range of Standard Stroke	Standard Stroke						L	L1	LA	LB	LD	LF	LG	LJ	LM	LK	LS	LT
		No Auto Switch			Auto Switch Exists														
		AA	AB	AC	AA	AB	AC												
32	5~50	56.2	32	9.6	66.2	42	19.8	17	38.5	30	57	6.6	57	71	5.8	M6×1.0	11.2	4	3.2
	75,100	66.2	42	19.8	63.7	39.5	23.5	17	38.5	33	64	6.6	64	78	7	M6×1.0	11.2	4	3.2
40	5~50	54.2	30	13.5	63.7	39.5	23.5	17	38.5	33	64	6.6	64	78	7	M6×1.0	11.2	4	3.2
	75,100	63.7	39.5	23.5	66.7	40.5	17.5	18	43.5	39	78	9	79	95	8	M8×1.25	14.7	5	3.2
50	10~50	56.7	30.5	7.5	66.7	40.5	17.5	18	43.5	39	78	9	79	95	8	M8×1.25	14.7	5	3.2
	75,100	66.7	40.5	17.5	72.2	46	20	18	43.5	46	91.5	11	95	113	9	M10×1.5	16.2	5	3.2
63	5~50	62.2	36	10	72.2	46	20	18	43.5	46	91.5	11	95	113	9	M10×1.5	16.2	5	3.2
	75,100	72.2	46	20															

Double Clevis Type/A(D)Q2KD

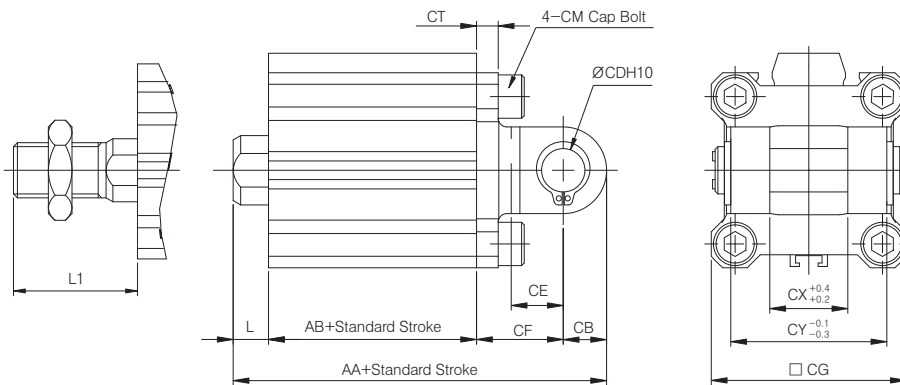

Material: Ø12~Ø25-Carbon Steel, Ø32~Ø100-Cast Iron

(Unit : mm)

Bore Size (Ø)	Range of Standard Stroke	Standard Stroke				L	L1	CB	CE	CF	CG	CM	CD	CT	CX	CY
		No Auto Switch		Auto Switch Exists												
		AA	AB	AA	AB											
32	5~50	69	32	79	42	7	28.5	10	14	20	45	M6×1.0	10 ^{+0.06} ₀	5	18	36
	75,100	79	42	78.5	39.5	7	28.5	10	14	22	52	M6×1.0	10 ^{+0.06} ₀	6	18	36
40	5~50	69	30	78.5	39.5	7	28.5	10	14	22	52	M6×1.0	10 ^{+0.06} ₀	6	18	36
	75,100	78.5	39.5	90.5	40.5	8	33.5	14	20	28	64	M8×1.25	14 ^{+0.07} ₀	7	22	44
50	10~50	80.5	30.5	90.5	40.5	8	33.5	14	20	28	64	M8×1.25	14 ^{+0.07} ₀	7	22	44
	75,100	90.5	40.5	98	46	8	33.5	14	20	30	77	M10×1.5	14 ^{+0.07} ₀	8	22	44
63	10~50	88	36	98	46	8	33.5	14	20	30	77	M10×1.5	14 ^{+0.07} ₀	8	22	44
	75,100	98	46													

※ In case of mounting attached cylinder, A-type tube is standard.

※ Indication and dimension are same as dimension of standard cylinder.

※ Cylinder and foot are delivered without assembly.

Series AQ2K, ADQ2K

Rod Side Flange Type/A(D)Q2KF

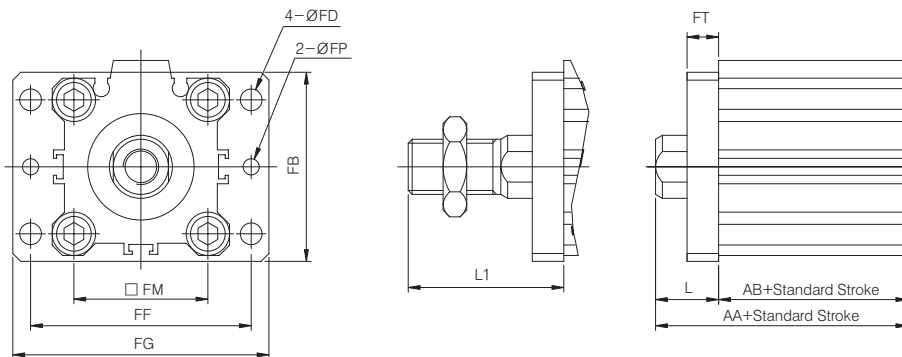

Material : Carbon Steel

(Unit : mm)

Bore Size (Ø)	Range of Standard Stroke	Standard Stroke				L	L1	FB	FD	FP	FF	FG	FM	FT
		No Auto Switch		Auto Switch Exists										
		AA	AB	AA	AB									
32	5~50	49	32	59	42	17	38.5	48	5.5	4.1	56	65	34	8
	75,100	59	42											
40	5~50	47	30	56.5	39.5	17	38.5	54	5.5	4.1	62	72	40	8
	75,100	56.5	39.5											
50	10~50	48.5	30.5	58.5	40.5	18	43.5	67	6.6	5.1	76	89	50	9
	75,100	58.5	40.5											
63	10~50	54	36	64	46	18	43.5	80	9	5.1	92	108	60	9
	75,100	64	46											

Head Side flange Type/A(D)Q2KG

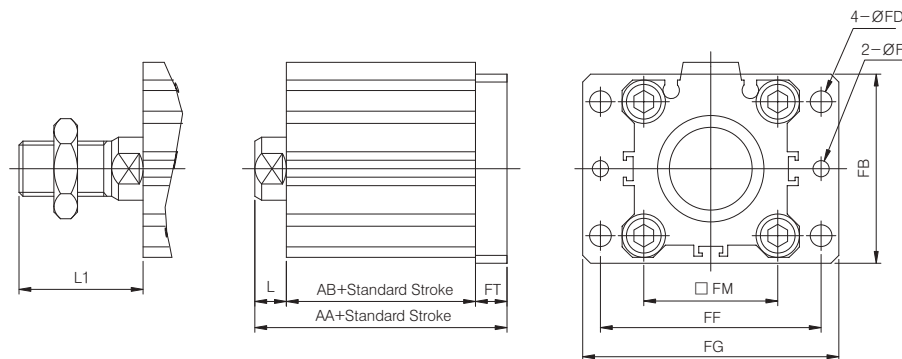

Material : Carbon Steel

(Unit : mm)

Bore Size (Ø)	Range of Standard Stroke	Standard Stroke				L	L1	FB	FD	FP	FF	FG	FM	FT
		No Auto Switch		Auto Switch Exists										
		AA	AB	AA	AB									
32	5~50	47	32	57	42	7	28.5	48	5.5	4.1	56	65	34	8
	75,100	57	42											
40	5~50	45	30	54.5	39.5	7	28.5	54	5.5	4.1	62	72	40	8
	75,100	54.5	39.5											
50	5~50	47.5	30.5	57.5	40.5	8	33.5	67	6.6	5.1	76	89	50	9
	75,100	57.5	40.5											
63	10~50	53	36	63	46	8	33.5	80	9	5.1	92	108	60	9
	75,100	63	46											

- * In case of mounting attached cylinder, A-type tube is standard.
- * Indication and dimension are same as dimension of standard cylinder.
- * Cylinder and foot are delivered without assembly.

Series AQ2K, ADQ2K

Separated Reference ▶ In Case of Both Ends Tap

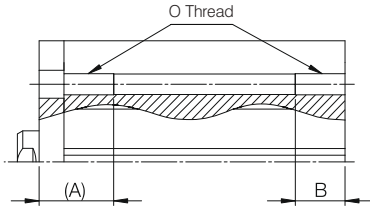

Standard Stroke

(Unit : mm)

Classification	Bore Size	O	A	B
AQ2A	Ø32	M6×1.0	10	10
	Ø40	M6×1.0	10	10
	Ø50	M8×1.25	14	14
	Ø63	M10×1.5	18	18

※ () : Rod Rotation prevention type

Auto Switch Specification

Items	Existing Contact Point (W8**)	Non Existing Contact Point (W9**)	Existing Contact Point (A73K)	Non Existing Contact Point (A73TN(P))
Size	External Diameter Ø4	External Diameter Ø4	-	
Loading Voltage	DC 24V, AC100V	DC 24V	DC24V, AC100	DC24V
Applied Current	5 ~ 40 mA (DC 24V) 5 ~ 20 mA (AC 110V)	5 ~ 30 mA	5 ~ 40 mA (DC 24V) 5 ~ 20 mA (AC 110V)	100 mA Less
Lead Track Direction	Vertical Type, Horizontal Type	Vertical Type, Horizontal Type	Vertical Type	
Lamp	Red LED ON When ON	Red LED ON When ON	Red LED ON When ON	
Wiring Method	2 Wire Type	2 Wire Type	2 Wire Type	3 Wire Type
Attachment Method	Screw Attached At Rail	Screw Attached At Ra	Rail Attachment type	
Operation Time	1.2ms or Less	1.2 ms or Less	1.2 ms or Less	
Internal Voltage Drop	2.4V or Less	4.5V or Less	2.4V or Less	1.5V or Less
Leakage Current	-	1.5mA or Less at DC 24V	-	

Auto Switch Mounting Position

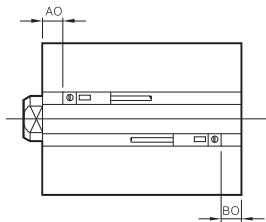

W8**, W9** Type

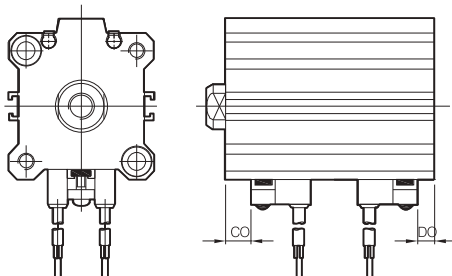

W4 Type

Standard Type

(Unit : mm)

Bore Size	Auto Switch Mounting Position						Remark
	W8**, W9** Type			W4 Type			
	AO	BO	Range of Operation	CO	DO	Range of Operation	
Ø12	7	7	8	-	-	-	
Ø16	12	7.5	10	-	-	-	General Single Motion Long Stroke Type
	2.5	3	5.5	-	-	-	
Ø20	11	9.5	9	-	-	-	
Ø25	2.5	2.5	9.5	-	-	-	
Ø32	12	9	5.5	9	6	12	
Ø40	16	11.5	5.5	13	8.5	11	
Ø50	14	14.5	5.5	11	11.5	10	
Ø63	16.5	17.5	6.5	13.5	14.5	12	
Ø80	20.5	21	5.5	17.5	18	12	
Ø100	24	27	6.5	21	24	13	

Note1) Only 1 auto switch is available for 5mm stroke.

ACP

APM

AS

AX

AM2

AM

AL
ALX

AQ
ADQ

AQ2
ADQ2

AJ
AJM

ABK

ACK1

NSK

AG

NGQ

AGX
GX

NP

ADR

AMR

NDM

ARD

NST

AST

ASTH

NLCD

NLCS

Series AQ2K, ADQ2K

Adjustable Stroke Cylinder/Extension Adjustable Type

AQ2B (Bore Size) (Stroke) D - XC8

The extended stroke of the cylinder can be adjusted by the stopper on the head side from full stroke(0~10mm).

Indication Symbol

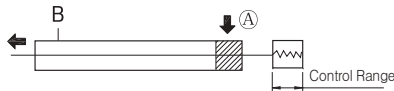

Specifications

Type	Air Pressure (non-Lubrication) Type
Tube Internal Diameter	32, 40, 50, 63, 80, 100
Operation Method	Double Motion
Applied Fluid	Air
Stroke Control Method	Stopper Control
Stroke Control Range	10mm
Attachment	Through Hole
Cushion	None
Minimum Applied Pressure	Ø12 : 0.07 MPa, Ø25 : 0.05 MPa

Constructions/Major Dimensions

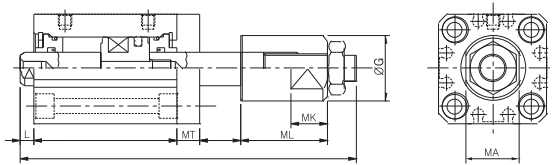

Standard Type

(Unit : mm)

Bore Size	Range of Produced Stroke	No Auto Switch		Auto Switch Exists		L	MT	ML	MK	G	MA
		AA	AB	AA	AB						
12	5 ~ 30	57.7	25.6	64.9	32	3.5	5	19	8	14	11
25	5 ~ 50	71.1	29	81.3	39	5	8	22.5	10	20	17
32	5 ~ 50	78.5	30.5	88.5	40.5	7	6	26	14	27	24
40	5 ~ 50	88	40	98	50	7	6	26	14	27	24
50	5 ~ 50	100.5	40.5	110.5	50.5	8	8	30	16	35	30
63	5 ~ 50	102	42	112	52	8	10	30	16	35	30
80	5 ~ 50	125	51	135	61	10	12	38	20	48	41
100	5 ~ 50	138.5	60.5	148.5	70.5	12	14	38	20	48	41

- ※ If auto switch does not exist, Ø25~5 stroke has penetrated both ends for attachment bolt of tube.
- ※ For both ends tap type, refer to p.333
- ※ Applied stroke has 5mm interval.
- ※ Ø20 apply as AQ Series (refer p.231)

Adjustable Stroke Cylinder/Retraction Adjustable Type

AQ2 (Attachment) (Bore Size) (Stroke) - D(M) - XC9

The retracted stroke of the cylinder can be adjusted from(0~10mm) by the adjusting bolt.

Indication Symbol

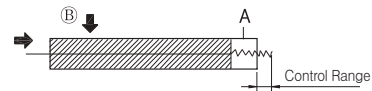

Specifications

Type	Air Pressure (non-Lubrication) Type
Tube Internal Diameter	32, 40, 50, 63, 80, 100
Operation Method	Double Motion
Applied Fluid	Air
Stroke Control Method	Control Bolt Control
Stroke Control Range	10 mm
Attachment	Through Hole (Standard), Both Ends Tap
Cushion	None
Minimum Applied Pressure	0.05 MPa

Dimensions

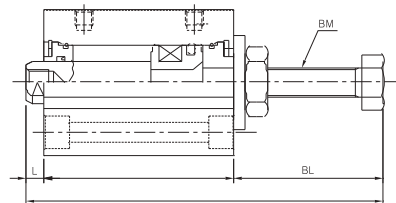

Standard Type

(단위 : mm)

Bore Size	Range of Produced Stroke	No Auto Switch		Auto Switch Exists		L	BL	BM
		AA	AB	AA	AB			
12	5 ~ 30	52.6	25.6	59	32	3.5	23.5	M×0.8
16	5 ~ 30	53	26	63	36	3.5	23.5	M6×1.0
25	5 ~ 50	63.5	29	73.5	39	5	29.5	M8×1.25
32	5 ~ 50	65.5	30.5	75.5	40.5	7	28	M8×1.25
40	5 ~ 50	84	40	94	50	7	37	M12×1.5
50	10 ~ 50	84.5	40.5	94.5	50.5	8	36	M12×1.5
63	10 ~ 50	88.5	42	98.5	52	8	38.5	M16×1.5
80	10 ~ 50	109.5	51	119.5	61	10	49.5	M20×1.5
100	10 ~ 50	125	60.5	135	70.5	12	52.5	M20×1.5

- ※ If auto switch does not exist, Ø25~5 stroke has penetrated both ends for attachment bolt of tube.
- ※ For both ends tap type, refer to p.333
- ※ Applied stroke has 5mm interval.
- ※ Ø20 apply as AQ Series (refer p.231)

Series AQ2K, ADQ2K

Dual Stroke Cylinder/Double rod Type

AQ2B (Bore Size) (Stroke S₁) + (Stroke S₂) D(C) (M)-XC10

Two cylinders are constructed as one cylinder in a back-to-back configuration allowing the cylinder stroke to be controlled in the three steps.

Symbols

Function

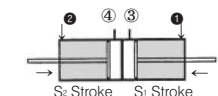

When air pressure is supplied to ports ① and ②, both S₁ and S₂ stroke retract.

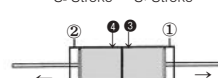

When air pressure is supplied to ports ③ and ④, both S₁ and S₂ stroke extend.

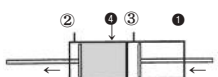

When air pressure is supplied to ports ① and ④, S₂ stroke extends and S₁ retracts strokes.

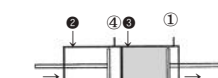

When air pressure is supplied to ports ② and ③, S₁ stroke extends and S₂ stroke retracts.

Specification

Type	Non lube
Bore Size	∅32, ∅40, ∅50, ∅63, ∅80, ∅100
Operation Method	Double Acting
Applied Fluid	Air
Attachment	Through Hole

Structure/External Dimension Drawing

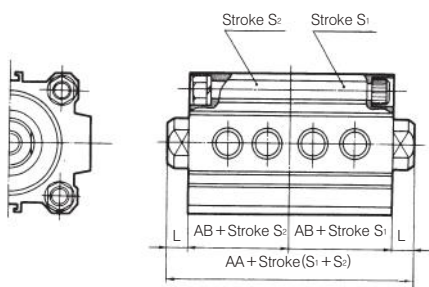

Bore Size (mm)	AA		AB		L	Produced Stroke S ₁ and S ₂ are Identical
	50st or Less	75, 100st or Less	50st or Less	75, 100st or Less		
32	60(80)	80(80)	23(33)	33(33)	7	5~100
40	73(93)	93(33)	29.5(39.5)	39.5(39.5)	7	
50	77(97)	97(97)	30.5(40.5)	40.5(40.5)	8	10~100
63	88(108)	108(108)	36(46)	46(46)	8	
80	107(127)	127(127)	43.5(53.5)	53.5(53.5)	10	
100	130(150)	150(150)	53(63)	63(63)	12	

* Dimensions in () are applied in auto switch attached case.
 * Refer to p.286(Notices) in case of middle stroke production.
 * In case of over 100st, refer to p.327 for AA and AB dimension.

Dual Stroke Cylinder/single rod Type

AQ2B (Bore Size) (Stroke S₁) + (Stroke S₂ - S₁) D(C)(M)-XC11

Two cylinders are constructed in serial as one cylinder. It is possible to control the cylinder stroke in two steps to obtain double the cylinder output force.

Symbols

Function

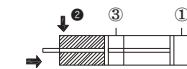

When air pressure is supplied to the ② port, both S₁ and S₂ stroke retract.

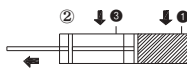

When air pressure is supplied to the ① port, the rod extends by the S₁ stroke length.

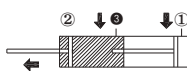

When air pressure is supplied to the ③ port, the rod operates S₂ - S₁.

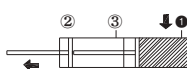

When air pressure is supplied to ①, rod moves S₁ stroke.

Specification

Type	Non lube
Bore Size	32, 40, 50, 63, 80, 100
Operation Method	Double Acting
Applied Fluid	Air
Attachment	Through Hole
Piston Speed	50 ~ 500 mm/s

Structure/External Dimension Drawing

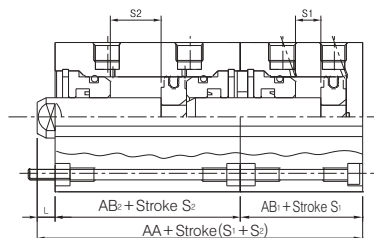

Standard Type

(Unit : mm)

Bore Size	Produced Stroke S ₁ and S ₂ are Identical	No Auto Switch			Auto Switch Exists			L
		AA	AB1	AB2	AA	AB1	AB2	
12	5 ~ 30	46.1	17	25.6	63.5	28	32	3.5
16	5 ~ 30	48	18.5	26	70	30.5	36	3.5
20	5 ~ 50	50	19.5	26	85	31.5	38	4.5
25	5 ~ 50	56.5	22.5	29	76.5	32.5	39	5
32	5 ~ 100	60.5	23	30.5	80.5	33	40.5	7
40	5 ~ 100	76.5	29.5	40	96.5	39.5	50	7
50	5 ~ 100	79	30.5	40.5	99	40.5	50.5	8
63	5 ~ 100	88	34	42	106	46	52	8
80	5 ~ 100	104.5	43.5	51	124.5	53.5	61	10
100	5 ~ 100	125.5	53	60.5	145.5	63	70.5	12

* Applied stroke has 5mm interval.

- ACP
- APM
- AS
- AX
- AM2
- AM
- AL
- ALX
- AQ
- ADQ
- AQ2**
- ADQ2**
- AJ
- AJM
- ABK
- ACK1
- NSK
- AG
- NGQ
- AGX
- GX
- NP
- ADR
- AMR
- NDM
- ARD
- NST
- AST
- ASTH
- NLCD
- NLCS

Specification **ORDER MADE**

Order Made for AQ2/TCQ2 Series Common Specification

Specification	Number	Symbol	Specification Contents
AQ2	①	-XR0~XR38	Rod end Shape Changed
	②	-XC8	Variable Stroke Cylinder (For Spring Return Motion)
	③	-XC9	Variable Stroke Cylinder (For Spring Extended Motion)
	④	-XC10	Dual Stroke Cylinder/Double Rod Type
	⑤	-XC11	Dual Stroke Cylinder/Single Rod Type
	⑥	-X202	Overall Length is Same as Basic
	⑦	-X203	L Size of Rod Cover is Same as Basic
	⑧	-X163	Coil Scraper Equipped (Tube Overall Length Increased)

Rod End Shape Changed (Refer to p.598) -XR0 ~ XR38

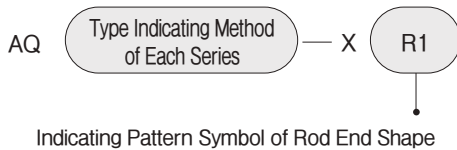

Shape Change of Operating Equipment and Applied Rod End

Series		Cylinder Name (Operating Method)	Rod End Shape Change Symbol
Compact Cylinder AQ	AQ	Standard Type	-XR0~XR38
	AQO-S	Standard Type for Single Acting Spring Return Type	

Patternized for rod end shape beside standard of AQ2 each series

Coil Scraper (Metal Scraper) Type

-X163

A(D)Q2B(A) — Bore Size — Cylinder Stroke — Operation Method — Body Specification — Switch Specification — X163

Bore Size (mm)	Index	Stroke(mm)					
		10~50	55~65	70	75	80~90	100
Ø32	Non Auto	33+Stroke	108	133	118	133	150.5
	Auto	43+Stroke					
Ø40	Non Auto	39.5+Stroke	114.5	139.5	124.5	139.5	160
	Auto	49.5+Stroke					
Ø50	Non Auto	40.5+Stroke	115.5	140.5	125.5	140.5	160.5
	Auto	50.5+Stroke					
Ø63	Non Auto	46+Stroke	121	146	131	146	162
	Auto	56+Stroke					
Ø80	Non Auto	53.5+Stroke	128.5	153.5	138.5	153.5	171
	Auto	63.5+Stroke					
Ø100	Non Auto	63+Stroke	138	163	148	163	180.5
	Auto	73+Stroke					

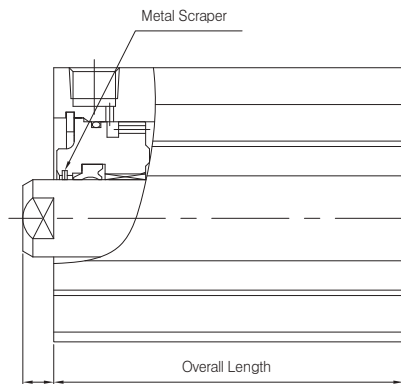

* L is same as standard dimension.