

Rodless Cylinder

APR Series

∅16, ∅20, ∅25, ∅32, ∅40, ∅50, ∅63

Variety of Options

Can select additional options according to customer's application.

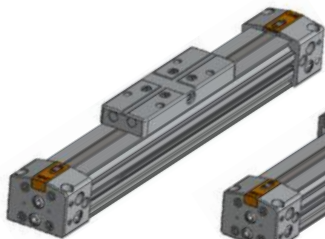

Basic Type

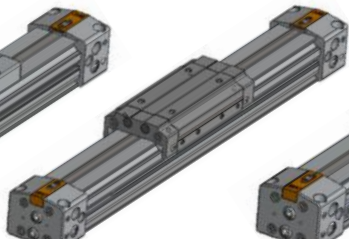

Outer Guide Type

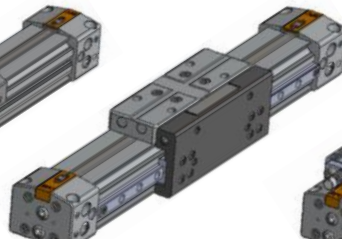

LM Guide Type

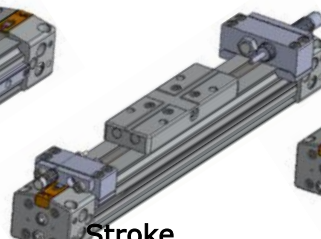

Stroke Adjustment Unit

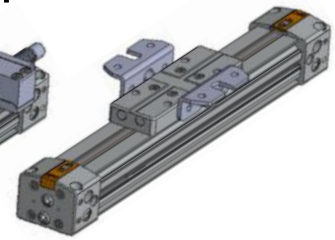

Floating Bracket

※ When using the LM Guide type, attach the workpiece to the table on the LM Guide side to prevent the workpiece from shaking.

Switch rails with double-sided mounting

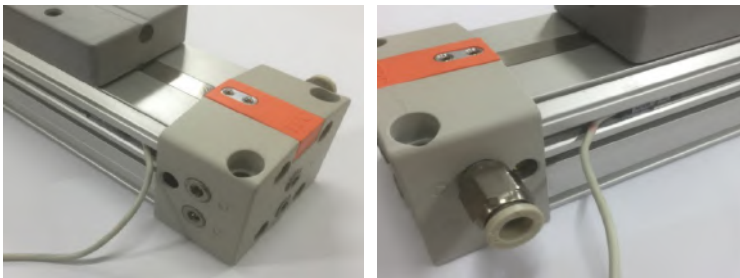

Compact auto switch can be mounted on both sides without separate mechanism

Centralized port system and 3-way piping available

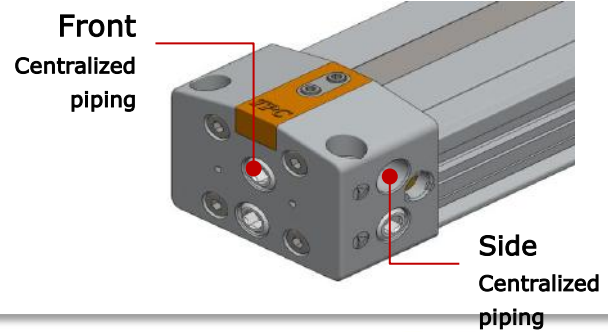

Front Centralized piping

Side Centralized piping

Floating Bracket

Used in combination with other separate external guides

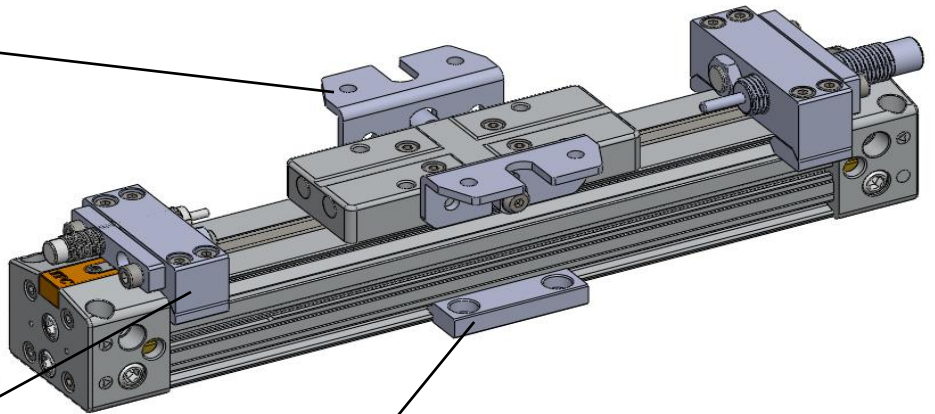
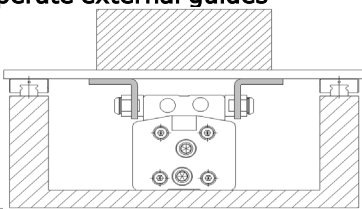

Stroke Adjustment Unit

One sided and two sided strokes can be adjusted

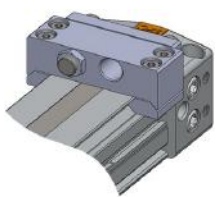

Adjustment bolt

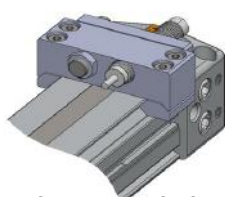

Adjustment bolt + Low load shock absorber

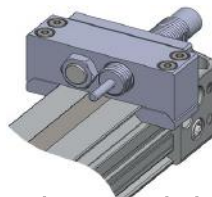

Adjustment bolt + High load shock absorber

Side Bracket

Long stroke cylinder tube deflection (warp) prevention

Tighten

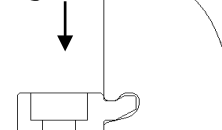

Tighten

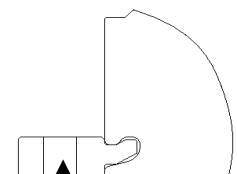

APR Series

Rodless cylinder / Bore size : Ø6, Ø20, Ø25, Ø32, Ø40, Ø50, Ø63

Actuator
Cylinder

APR Series

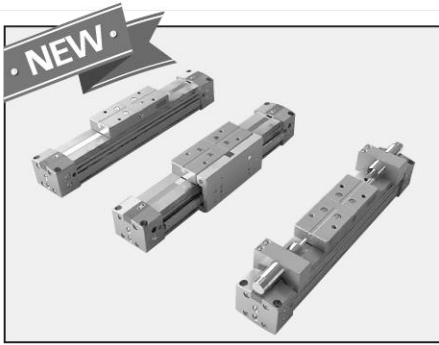

- Implemented maximum stroke of 5,000mm
- High rigidity and durability
- Reduced in weight
- More options added such as LM Guide and shock absorber

How to order

APR **16** **A** - **1000 L1L2** - **SA** **N** - **J** - **W8H** 

1 2 3 4 5 6 7 8 9

1 Rodless cylinder series Built-in magnet type

2 Bore size

16 : 16mm
20 : 20mm
25 : 25mm
32 : 32mm
40 : 40mm
50 : 50mm
63 : 63mm

3 Guide type

A : Basic type
B : External guide
C : LM guide mounted
(Not available for Ø50, Ø63)

4 Maximum stroke length (mm)

A, B type / C type
16 : 3,000 / 1,000
20 : 3,000 / 1,000
25 : 5,000 / 1,000
32 : 5,000 / 1,000
40 : 5,000 / -
50 : 5,000 / -
63 : 5,000 / -
* Please contact us for longer than maximum Stroke length.

5-1 Stroke adjustment unit(1)

Blank : None
B1 : Shock absorber (One side)
B2 : Shock absorber (Both-sides)*
* Only applicable to basic type
* B2 option only available for bore sizes 16-40mm

5-2 Stroke adjustment unit(2)

Please refer to the installation preference on p.
* Adjustment unit(1) and (2) cannot be used together

6-1 Option(1)

SA : One side
SB : Both sides
* LM Guide type is not applicable

6-2 Suffix symbol for options(1)

Blank : 1 set (2ea)
N : n sets

7 Options(2)

Blank : None
J : Floating bracket (Only applicable to Basic type)

8 Auto switch (Micro)

Blank : No auto switch
W8H : Micro reed switch (Horizontal, 2 wires)
(Applicable for both DC24V and AC110V)
W8V : Micro reed switch (Vertical, 2 wires)
(Applicable for both DC24V and AC110V)
W9H : Micro solid state switch
(Horizontal, 2 wires) (DC24V)
W9V : Micro solid state switch
(Vertical, 2 wires) (DC24V)
* Refer to page 200 for more information.

9 Number of auto switches

Blank : 2 pcs
N : N pcs

Specifications

Part number	APR016	APR020	APR025	APR032	APR040	APR050	APR063
Action	Double-acting						
Fluid	Non-lube Air						
Operating pressure (kPa)	150 ~ 800						
Operating pressure (kPa)	200 ~ 800	150 ~ 800					
Operating temp. (°C)	5 ~ 60						
Operating speed (mm/s)	150 ~ 2,000			100 ~ 2,000			
Cushion	Air cushion						
Mounting type	Basic						
Lubrication	Unnecessary						
Magnet	Built-in						
Auto switch	W8H (Micro reed 2-wired), W9H (Micro solid state 2-wired)						

Specification



Basic type (A Type)

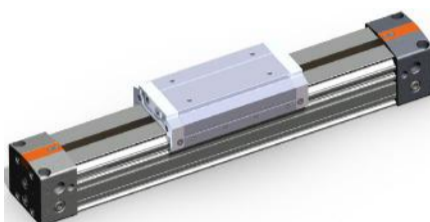

External guide type (B Type)

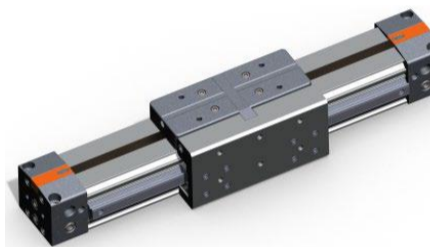

LM guide type (C Type)

Bore size(mm)		16	20	25	32	40	50	63
Fluid		Compressed air						
Action		Double acting						
Operating pressure range (kPa)		200 ~ 800		150 ~ 800				
Ambient and fluid temperature (°C)		5 ~ 60						
Cushion		Variable air cushion						
Support Type		Basic type						
Lubrication		Non-lube						
Speed (mm/s)	A Type	150 ~ 2,000			100 ~ 2,000			
	B Type	150 ~ 1,500			100 ~ 1,500			
	C Type	150 ~ 1,500			100 ~ 1,500		-	-
Port size		M5x0.8		Rc1/8		Rc1/4	Rc3/8	Rc1/2
Switch magnet		Basic : built-in						
AUTO switch		W8H(Micro reed, 2-wire), W9H(Micro solid state, 2-wire)						
Stroke length tolerance	A Type	1000 or less	+1.5 0	1000 or less , 1001~3000		+1.5 +2.0 0	3000 or greater +2.5 0	
	B Type	1001~3000	+2.0 0					
	C Type	Less 1000	+1.5 0				Less 1000 +1.5 0	1001~2000 +2.0 0

※ Ø50, Ø63 with LM Guide(C type) are not available.

Stroke

(Unit : mm)

Type	Standard	Stroke	Max. stroke
Basic type (A Type)	16, 20	100, 200, 300, 400, 500, 600, 700, 800, 900, 1000,	3000
External guide type (B Type)	25, 32, 40, 50, 63	1200, 1400, 1600, 1800, 2000	5000
LM Guide type (C Type)	16, 20, 25, 32	100, 200, 300, 400, 500, 600, 700, 800, 900, 1000	1000
	40		2000

※ Strokes can be manufactured in 1mm increments. Please contact us for strokes beyond the maximum stroke.

※ Under 50 strokes, the capacity of the air cushion deteriorates and multiple auto switches may not be mounted.

※ Since the loadless cylinder is an air cylinder with its own sealing structure, slight external leakage exists.

The slight leakage may increase when used for intermediate shutdown of the stroke, but there are no problems in use.

Theoretical Output

(Unit N)

Bore size (mm)	Water pressure area (mm ²)	Applied Pressure (MPa)							
		0.15	0.2	0.3	0.4	0.5	0.6	0.7	0.8
16	201	30	40	60	80	101	121	141	161
20	314	47	63	94	126	157	188	220	251
25	491	74	98	147	196	245	295	344	393
32	804	121	161	241	322	402	483	563	643
40	1,257	188	251	377	503	628	754	880	1,005
50	1,963	295	393	589	785	982	1,178	1,374	1,571
63	3,117	468	623	935	1,247	1,559	1,870	2,182	2,494

Weight Table

[Basic type (A Type)]

(Unit g)

Standard	APR16A	APR20A	APR25A	APR32A	APR40A	APR50A	APR63A
Standard weight	350	680	950	1,800	3,150	5,350	9,500
Stroke per 10mm	12	20	23	35	51	80	128

[External guide type (B Type)]

(Unit g)

Standard	APR16B	APR20B	APR25B	APR32B	APR40B	APR50B	APR63B
Standard weight	295	630	1000	1,900	3,400	6,000	10,630
Stroke per 10mm	12	20	23	35	51	80	128

[LM guide type (C Type)]

(Unit g)

Standard	APR16C	APR20C	APR25C	APR32C	APR40C
Standard weight	521	888	1,308	2,401	4,583
Stroke per 10mm	16	20	25	39	58

[Option Specifications]

(Unit g)

Model		APR16	APR20	APR25	APR32	APR40	APR50	APR63
Stroke adjustment unit (1set)	Adjustment bolt	27	49	71	137	240	414	733
	Low load	49	72	111	215	337	642	990
	High load	-	107	188	395	503	919	1396

※ Based on basic bracket standards

Weight Calculation Method

(EX) APR32A – 200

Standard weight 1,800g

Additional weight 35/10mm stroke

Stroke 200mm stroke

Weight $1,800 + 35 \times 20 = 2,500g$

Stroke adjustment unit mounting diagram

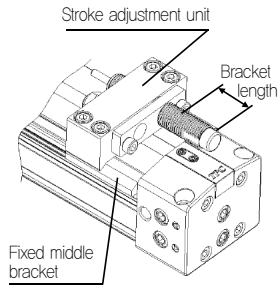

H1L2 mounting example

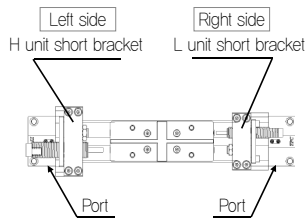

Stroke adjustment unit mount symbols

		Right side Stroke adjustment unit										
		No unit	Adjustment bolt			Adjustment bolt + shock absorber low load type			Adjustment bolt + shock absorber high load type			
			Adjustment bolt	Short(1) bracket	Long(2) bracket	Adjustment bolt	Short(1) bracket	Long(2) bracket	Adjustment bolt	Short(1) bracket	Long(2) bracket	
Left side stroke adjustment unit	No unit	Blank	SA0	SA1	SA2	SL0	SL1	SL2	SH0	SH1	SH2	
	Adjustment bolt	Adjustment bolt	A0S	A0A0	A0A1	A0A2	A0L0	A0L1	A0L2	A0H0	A0H1	A0H2
		Short(1) bracket	A1S	A1A0	A1A1	A1A2	A1L0	A1L1	A1L2	A1H0	A1H1	A1H2
		Long(2) bracket	A2S	A2A0	A2A1	A2A2	A2L0	A2L1	A2L2	A2H0	A2H1	A2H2
	Adjustment bolt + shock absorber Low load type	Adjustment bolt	L0S	L0A0	L0A1	L0A2	L0L0	L0L1	L0L2	L0H0	L0H1	L0H2
		Short(1) bracket	L1S	L1A0	L1A1	L1A2	L1L0	L1L1	L1L2	L1H0	L1H1	L1H2
		Long(2) bracket	L2S	L2A0	L2A1	L2A2	L2L0	L2L1	L2L2	L2H0	L2H1	L2H2
	Adjustment bolt + shock absorber High load type	Adjustment bolt	H0S	H0A0	H0A1	H0A2	H0L0	H0L1	H0L2	H0H0	H0H1	H0H2
		Short(1) bracket	H1S	H1A0	H1A1	H1A2	H1L0	H1L1	H1L2	H1H0	H1H1	H1H2
		Long(2) bracket	H2S	H2A0	H2A1	H2A2	H2L0	H2L1	H2L2	H2H0	H2H1	H2H2

※ Short bracket and long bracket are used to fix the adjustment unit in the middle.

Stroke adjustment unit mount symbols

Bore size		16			20			25			32			40			50			63		
Unit symbol		A	L	A	L	H	A	L	H	A	L	H	A	L	H	A	L	H	A	L	H	
Components (Shock absorber type)		Adjustment bolt	0806 + Adjustment bolt	Adjustment bolt	0806 + Adjustment bolt	1008 + Adjustment bolt	Adjustment bolt	1008 + Adjustment bolt	1415 + Adjustment bolt	Adjustment bolt	1415 + Adjustment bolt	2020 + Adjustment bolt	Adjustment bolt	1415 + Adjustment bolt	2020 + Adjustment bolt	Adjustment bolt	2020 + Adjustment bolt	2525 + Adjustment bolt	Adjustment bolt	2020 + Adjustment bolt	2525 + Adjustment bolt	
Stroke adjustment range per bracket length	Standard bracket	0 ~ -5,6			0 ~ -6			0 ~ -11,5			0 ~ -12			0 ~ -16			0 ~ -20			0 ~ -25		
	Short bracket	-5,6 ~ -11,2			-6 ~ -12			11,5 ~ -23			-12 ~ -24			-16 ~ -32			-20 ~ -40			-25 ~ -50		
	Long bracket	-11,2 ~ -16,8			-12 ~ -18			-23 ~ -34,5			-24 ~ -36			-32 ~ -48			-40 ~ -60			-50 ~ -75		

※ The stroke adjustment range is the side adjustment range when mounted on the cylinder.

※ Please note that theAir cushion capacity decreases when the stroke adjustment becomes larger due to the adjustment bolt.

※ If adjustment bolt type, the piston speed is 100-200mm/s when used outside theAir cushion range.

Shock Absorber Specification

Model	08-06	10-08	14-15	20-20	25-25	
Total energy (Nm/cycle)	5	11	34	105	226	
Stroke (mm)	6	8	15	20	25	
Max. collision speed (m/s)	2.0					
Max. operating frequency (cycle/min)	26	21	25	8	5	
Spring force (N)	Extended	2.2	2.5	3.8	8.2	11
	Retracted	5.8	6.9	13.3	23	29
Operating temperature range ()	-10 ~ 80					
Screw standard	M8 x P1.0	M10 x P1.0	M14 x P1.5	M20 x P1.5	M25 x P2.0	

※ The life of the shock absorber differs from that of the cylinder itself. Please refer to the shock absorber standard for the replacement standard.

<Precautions>

※ Air cushion is standard built in for the APR series.

The air cushion is installed for the purpose of preventing the piston with large kinetic energy from touching while impacting when stopping at the stroke end.

Refer to page 24 for load weight and speed range that can be absorbed by the air cushion.

※ The stroke adjustment unit with built-in shock absorber is used for loads and speeds above the limit of the air cushion, or when the stroke adjustment requires a cushion outside the range of the air cushion.

※ If the effective stroke of the shock absorber is shortened by the stroke adjustment, the absorption capacity is greatly reduced. Therefore, when adjusting the stroke with the adjustment bolt, adjust the adjustment bolt so that it protrudes about 0.5 mm from the shock absorber (shown on the right).

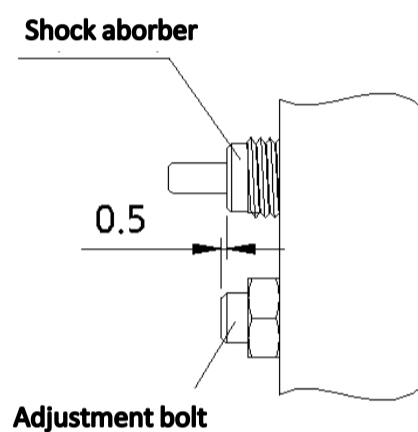

How to order stroke adjustment unit

APR – **U** **25** **L** – **ON**

1
 2
 3
 4

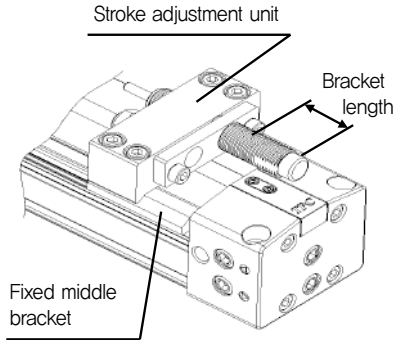

1 Stroke adjustment unit

2 Bore size

16 : 16mm
 20 : 20mm
 25 : 25mm
 32 : 32mm
 40 : 40mm
 50 : 50mm
 63 : 63mm

3 Unit

A : A unit (Adjustment bolt)
 L : L unit (Low load type)
 H : H unit (High load type)

4-1 Bracket type

0 : Standard bracket
 1 : Short bracket
 2 : Long bracket

4-2 Shipped bracket Type

Blank : Unit assembly
 N : Bracket only

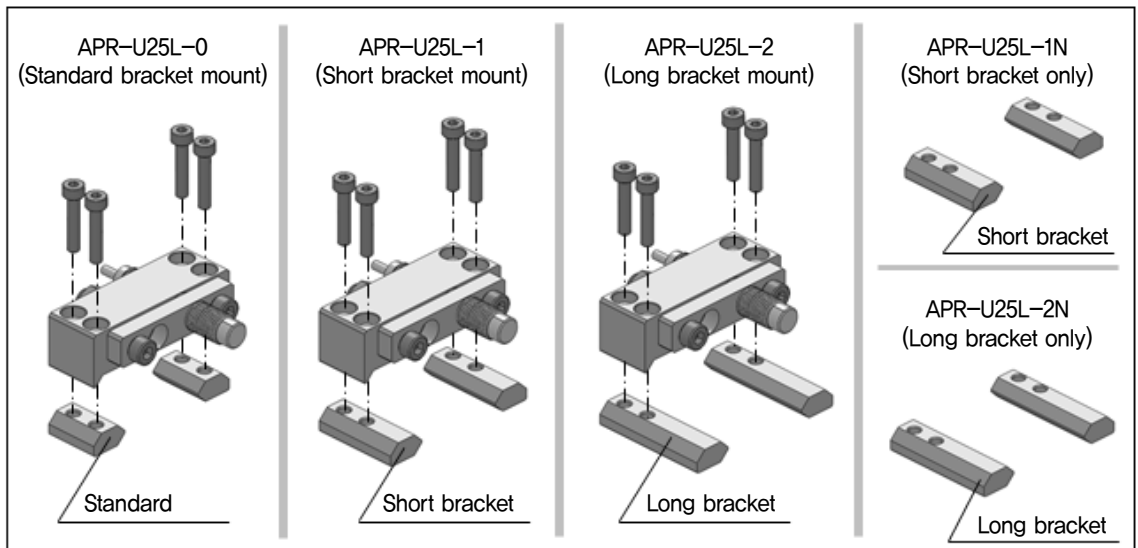

How to order side bracket

APR – **S** **25** **L**

1
 2
 3

1 Side bracket

2 Bore size

16 : 16mm
 20 : 20mm
 25 : 25mm
 32 : 32mm
 40 : 40mm
 50 : 50mm
 63 : 63mm

3 Type

A : Hole type
 B : Tap type

How to order floating joint bracket

APR – **J** **25**

1

1 Bore size

16 : 16mm
 20 : 20mm
 25 : 25mm
 32 : 32mm
 40 : 40mm
 50 : 50mm
 63 : 63mm

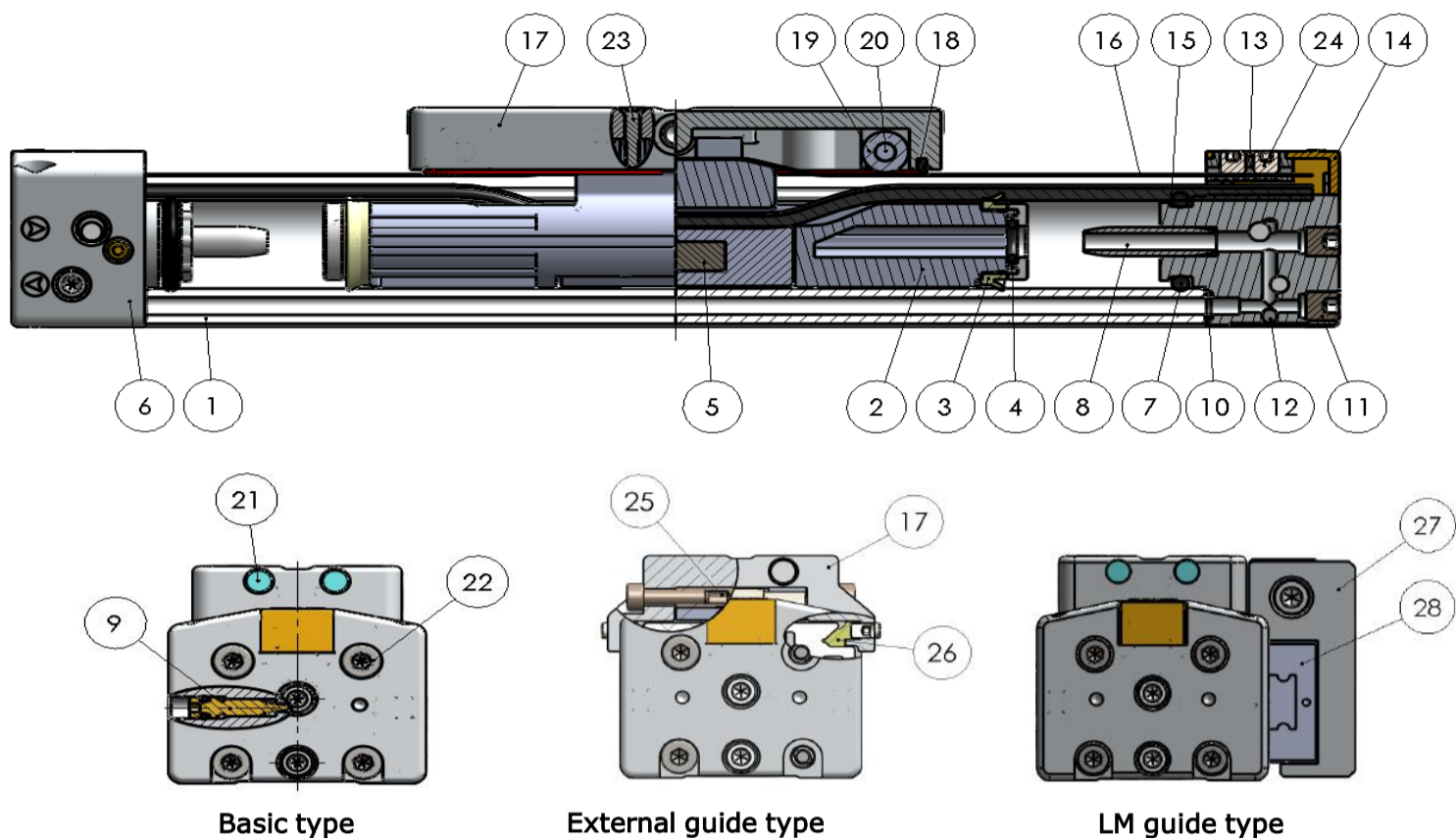

Basic type

External guide type

LM guide type

NO.	Description	Material	Quantity	Note
1	CYLINDER TUBE	Aluminum alloy	1	Hard anodized
2	PISTON	Special resin	1	
3	PISTON PACKING	Polyurethane	2	
4	CUSHION PACKING	Synthetic rubber	2	
5	MAGNET	-	2	
6	END COVER	Aluminum alloy	1	Painted
7	O-RING	Synthetic rubber	2	
8	SLEEVE	Aluminum alloy	2	
9	CUSHION VALVE	Steel	2	
10	O-RING	Synthetic rubber	2	
11	PORT PLUG	Chromium molybdenum steel	10	
12	STEEL BALL	Stainless steel	2	
13	CLAMP	Zinc alloy	2	
14	CLAMP HOLDER	Special resin	2	
15	SEAL STRIP	Polyurethane	1	
16	DUST COVER	Stainless steel	1	
17	SLIDE TABLE	Aluminum alloy	1	Chromated
18	WIPER	Special resin	1	
19	ROLLER	Special resin	2	
20	ROLLER SHAFT	Stainless steel	2	
21	STOPPER	Chromium molybdenum steel	4	
22	Hexagon socket head cap screw	-	8	
23	TAPPING SCREW	-	4	
24	SET SCREW	-	4	
25	TABLE FIXING PLATE	Aluminum alloy	2	
26	SLIDE	Special resin	4	
27	LM TABLE	Aluminum alloy	2	
28	LM GUIDE	-	2	

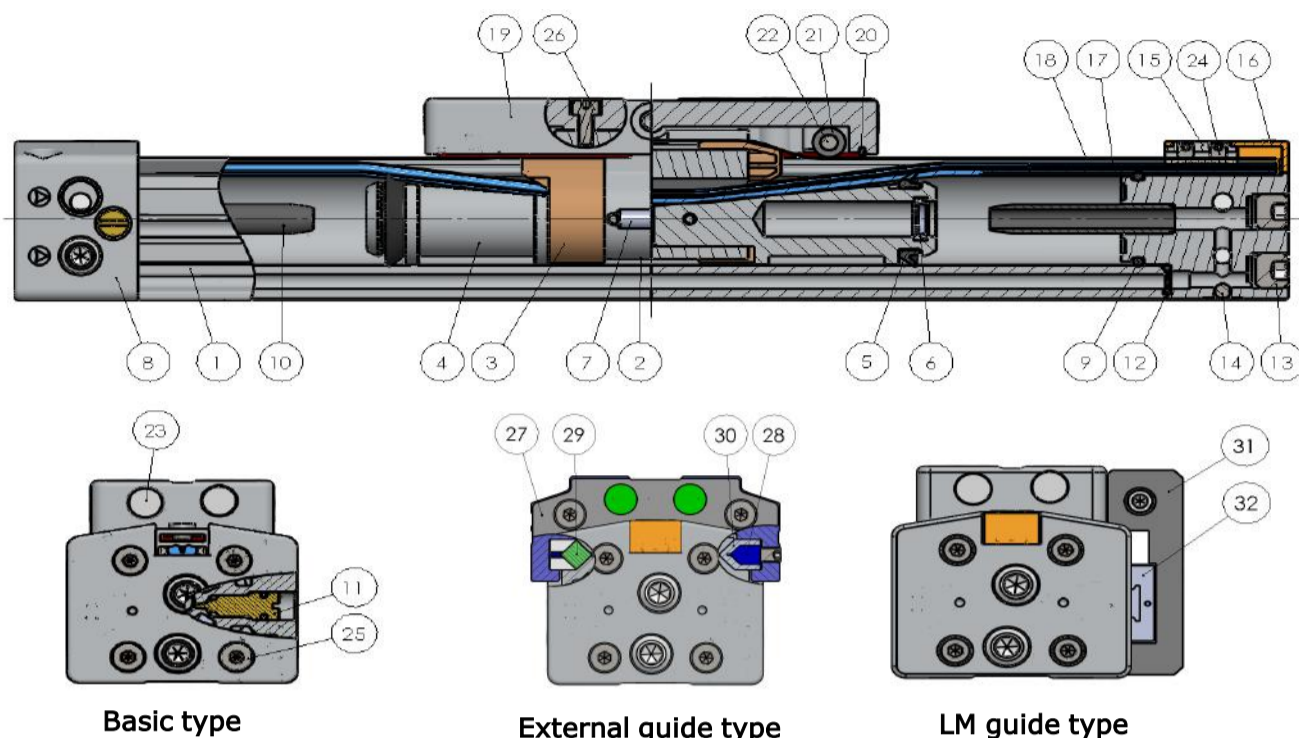

NO.	Description	Material	Quantity	Note
1	CYLINDER TUBE	Aluminum alloy	1	Hard anodized
2	YOKE	Aluminum alloy	1	
3	BAND DIVIDER	Special resin	2	
4	PISTON	Aluminum alloy	2	
5	PISTON PACKING	Polyurethane	2	
6	CUSHION PACKING	Synthetic rubber	2	
7	MAGNET	-	2	
8	END COVER	Aluminum alloy	1	Painted
9	O-RING	Synthetic rubber	2	
10	SLEEVE	Aluminum alloy	2	
11	CUSHION VALVE	Steel	2	
12	O-RING	Synthetic rubber	2	
13	PORT PLUG	Chromium molybdenum steel	10	
14	STEEL BALL	Stainless steel	2	
15	CLAMP	Zinc alloy	2	
16	CLAMP HOLDER	Special resin	2	
17	SEAL STRIP	Polyurethane	1	
18	DUST COVER	Stainless steel	1	
19	SLIDE TABLE	Aluminum alloy	1	Chromated
20	WIPER	Special resin	1	
21	ROLLER	Special resin	2	
22	ROLLER SHAFT	Stainless steel	2	
23	STOPPER	Chromium molybdenum steel	4	
24	SET SCREW	-	4	
25	Hexagon socket head cap screw	-	8	
26	Hexagon socket head cap screw	-	4	
27	SLIDE TABLE COVER	Aluminum alloy	2	
28	PRESSURE BAR	Stainless steel	4	
29	FELT	Wool	2	
30	SLIDE	Special resin	4	
31	LM TABLE	Aluminum alloy	1	
32	LM GUIDE		1	

Basic Type Dimensions

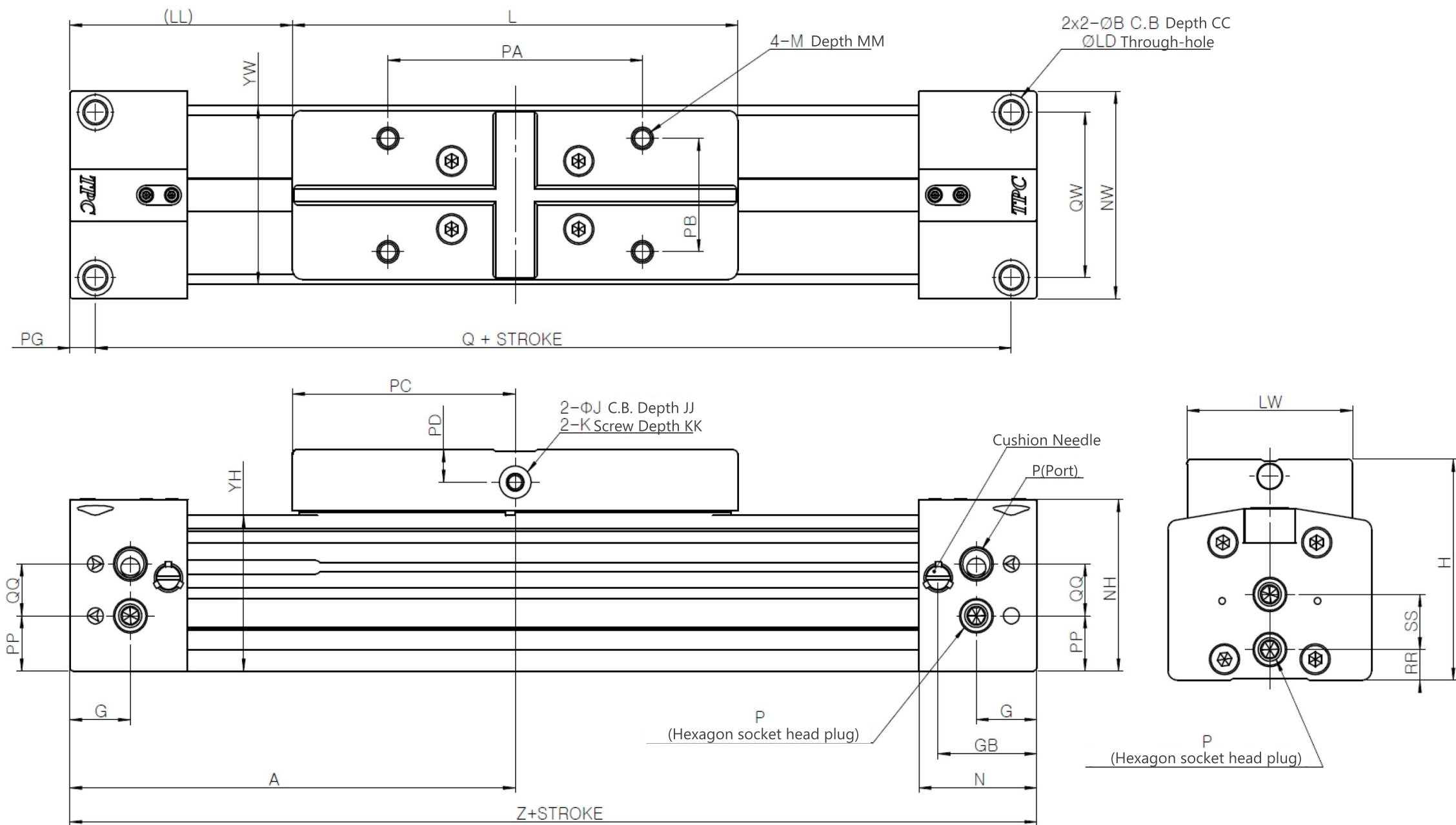

(Unit : mm)

Bore Size	A	B	C	G	GB	H	J	JJ	K	KK	L	LL	LD	LW	M	MM	N
16	80	6	3	12	16	37.3	7	2	M4	6.5	80	40	3.5	30	M4	6	20
20	100	7.5	4.5	12	21	46.6	8	2	M4	10	100	50	4.5	37	M5	8	25
25	110	9	5.5	16	24	54.5	10	2	M5	9	110	55	5.6	42	M5	9	30
32	140	11	6.6	19	31	68.2	10	2	M5	10	140	70	6.8	52	M6	12	37
40	170	14	8.5	23	37	84.3	14	2	M6	13	170	85	8.6	64	M6	12	45
50	200	14	8.5	22.5	34	95	15	3	M6	17	200	100	9	80	M8	14	47
63	230	17	10.5	29	34	117	16	3	M8	24	230	115	11	96	M8	16	50

Bore Size	NH	NW	P	PA	PB	PC	PD	PG	PP	Q	QQ	QW	RR	SS	YH	YW	Z
16	29.9	37	M5	40	20	40	4.5	3.5	7.2	153	9.5	30	3.5	11	26	35	160
20	36.8	45	M5	50	25	50	5	4.5	10.5	191	11	36	7	11.5	32.5	40	200
25	42.9	53	Rc 1/8	60	30	55	6	7	12	206	16	42	8	16	38.5	46	220
32	52.9	64	Rc 1/8	80	35	70	10	8	17	264	16	51	9.5	17	48	55	280
40	65.4	75	Rc 1/4	100	40	85	12	9	18.5	322	24	59	12	21.8	60.5	67	340
50	79.7	92	Rc 3/8	120	50	100	8.5	8	24	384	27	76	13	29	74	92	400
63	100.3	112	Rc 1/2	140	60	115	9.5	10	27	440	37	92	18	37.2	94	112	460

Outer Guide Type Dimensions

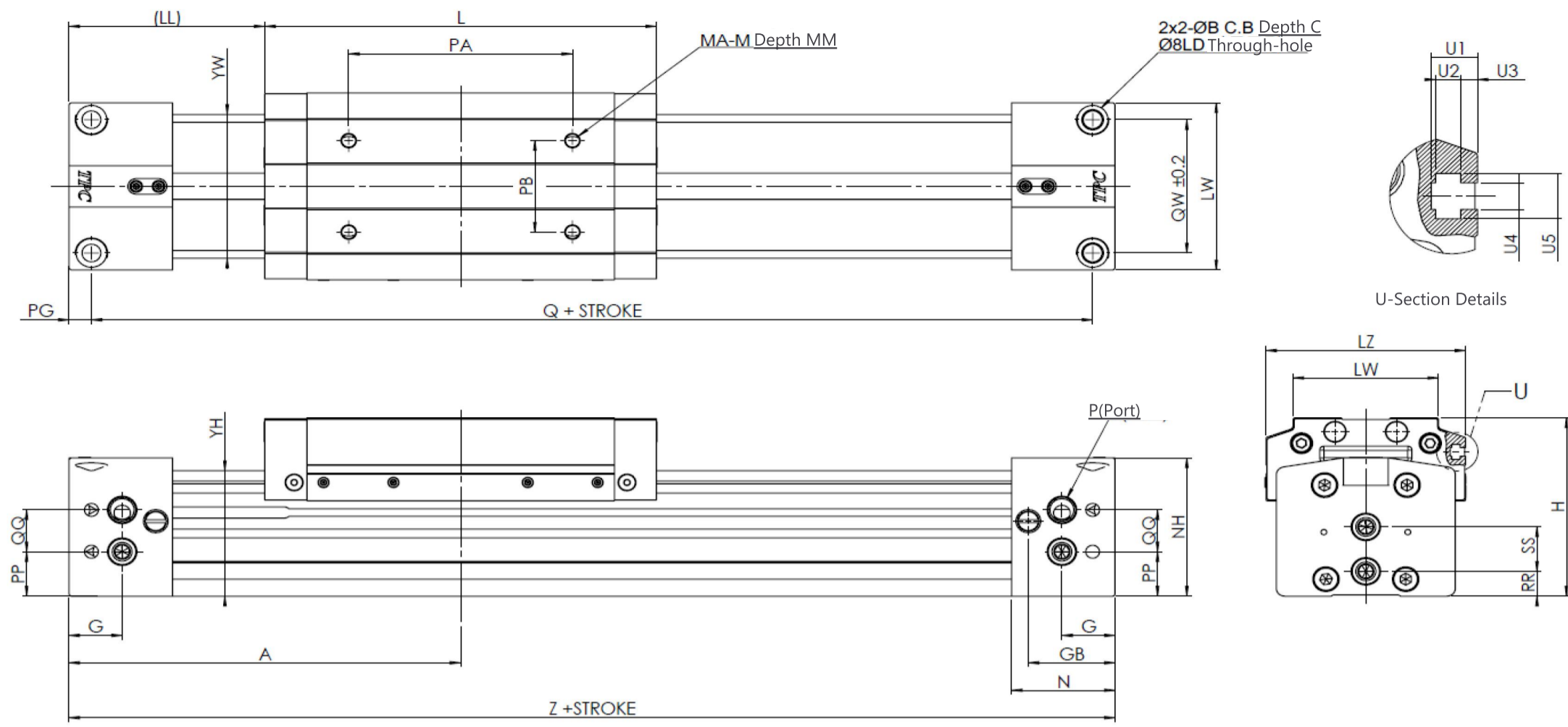

(Unit : mm)

Bore Size	A	B	C	G	GB	H	L	LL	LD	LW	LZ	M	MA	MM	N
16	80	6	3	12	16	37.3	80	40	3.5	30	41	M4	4	6	20
20	100	7.5	4.5	12	21	46.6	100	50	4.5	37	51.8	M5	4	7	25
25	110	9	5.5	16	24	54.5	110	55	5.6	42	61	M5	4	9	30
32	140	11	6.6	19	31	68.2	140	70	6.8	52	71.4	M6	4	10	37
40	170	14	8.5	23	37	84.3	170	85	8.6	64	90	M6	4	12	45
50	200	14	8.5	22.5	34	95	200	100	9	80	113	M8	6	10	47
63	230	17	10.5	29	34	117	230	115	11	96	136	M8	6	10	50

Bore Size	NH	NW	P	PA	PB	PG	PP	Q	QQ	QW	RR	SS	YH	YW	Z
16	29.9	37	M5	40	20	3.5	7.2	153	9.5	30	3.5	11	26	35	160
20	36.8	45	M5	50	25	4.5	10.5	191	11	36	7	11.5	32.5	40	200
25	42.9	53	Rc 1/8	60	30	7	12	206	16	42	8	16	38.5	46	220
32	52.9	64	Rc 1/8	80	35	8	17	264	16	51	9.5	17	48	55	280
40	65.4	75	Rc 1/4	100	40	9	18.5	322	24	59	12	21.8	60.5	67	340
50	79.7	92	Rc 3/8	120	50	8	24	384	27	76	13	29	74	92	400
63	100.3	112	Rc 1/2	140	60	10	27	440	37	92	18	37.2	94	112	460

U Section Dimensions

Bore Size	U1	U2	U3	U4	U5
16	-	-	-	-	-
20	5.5	3	2	3.4	5.8
25	5.5	3	2	3.4	5.8
32	5.5	3	2	3.4	5.8
40	6.5	3.8	2	4.5	7.3
50	6.5	3.8	2	4.5	7.3
63	8.5	5	2.5	5.5	8.4

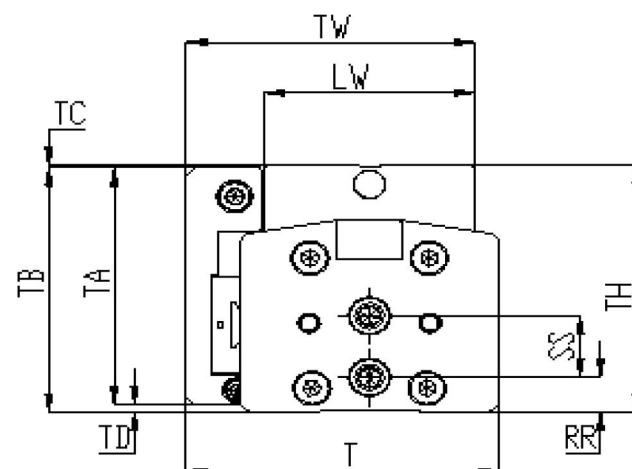
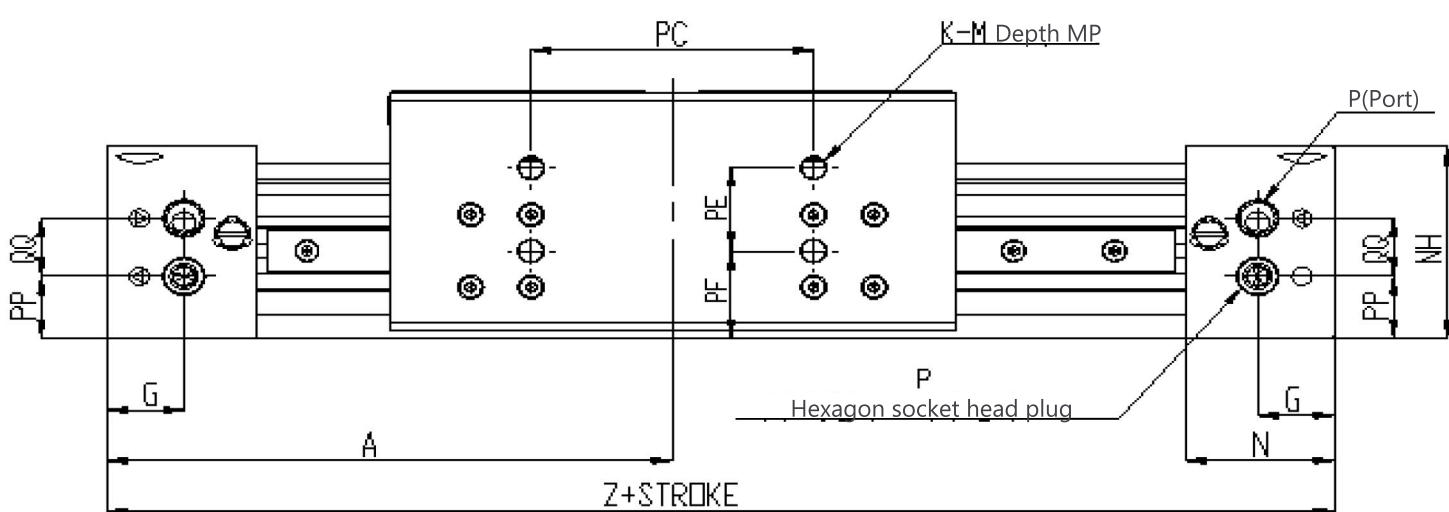
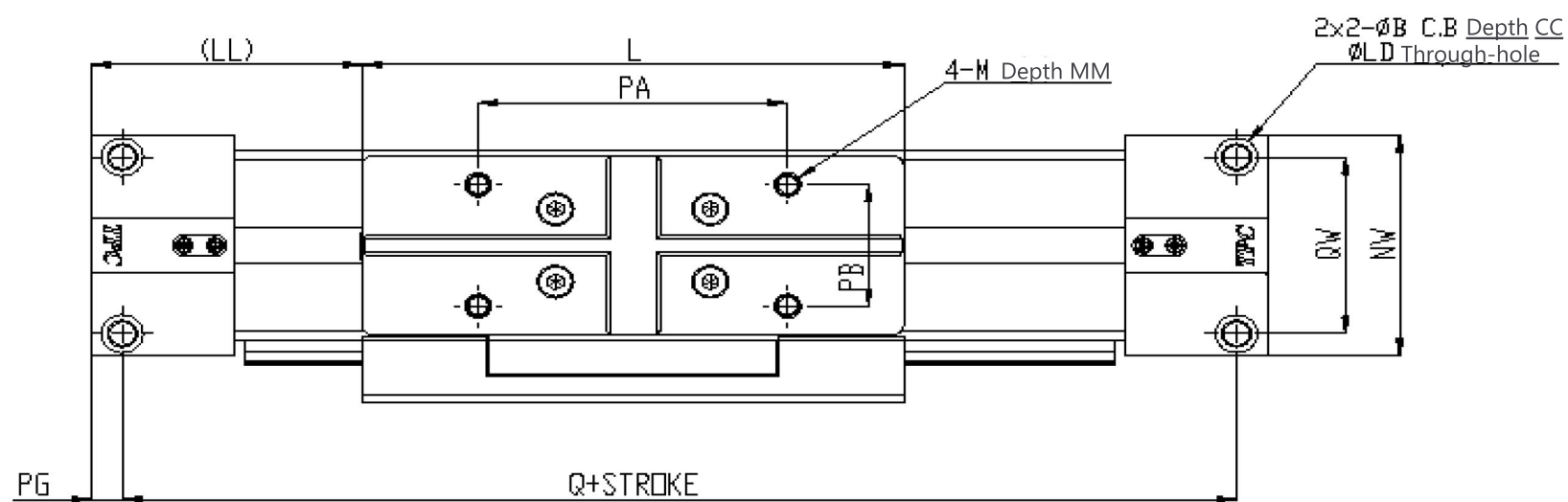

(Unit : mm)

Bore Size	A	B	C	G	K	L	LD	LL	LW	M	MM	MP	N	NH	NW	P	PA	PB	PC
16	80	6	3	12	4	80	3.5	40	30	M4	6	6	20	29.9	37	M5	40	20	40
20	100	7.5	4.5	12	4	100	4.5	50	37	M5	8	6	25	36.8	45	M5	50	25	50
25	110	9	5.5	16	4	111	5.6	55	42	M5	9	6	30	42.9	53	Rc 1/8	60	30	60
32	140	11	6.6	19	4	140	6.8	70	52	M6	12	6	37	52.9	64	Rc 1/8	80	35	70
40	170	14	8.5	23	6	170	8.6	85	64	M6	12	7.5	45	65.4	75	Rc 1/4	100	40	100

Bore Size	PE	PF	PG	PP	Q	QQ	QW	RR	SS	T	TA	TB	TC	TD	TH	TW	Z
16	18	12.5	3.5	7.2	153	9.5	30	3.5	11	51	35.9	36.5	0.8	0.6	37.3	47.5	160
20	16	14.8	4.5	10.5	191	11	36	7	11.5	57.5	44.7	45.6	1.1	0.9	46.6	53.5	200
25	26	19.6	7	12	206	16	42	8	16	64.5	52.8	53.6	1	0.8	54.5	59	220
32	23	24	8	17	264	16	51	9.5	17	77.4	65.5	67.5	0.7	2	68.2	71.4	280
40	40	22.3	9	18.5	322	24	59	12	21.8	104.5	82	83.3	1.1	1.3	84.3	99	340

With SHOCK-ABSORBER (Ø16~40)

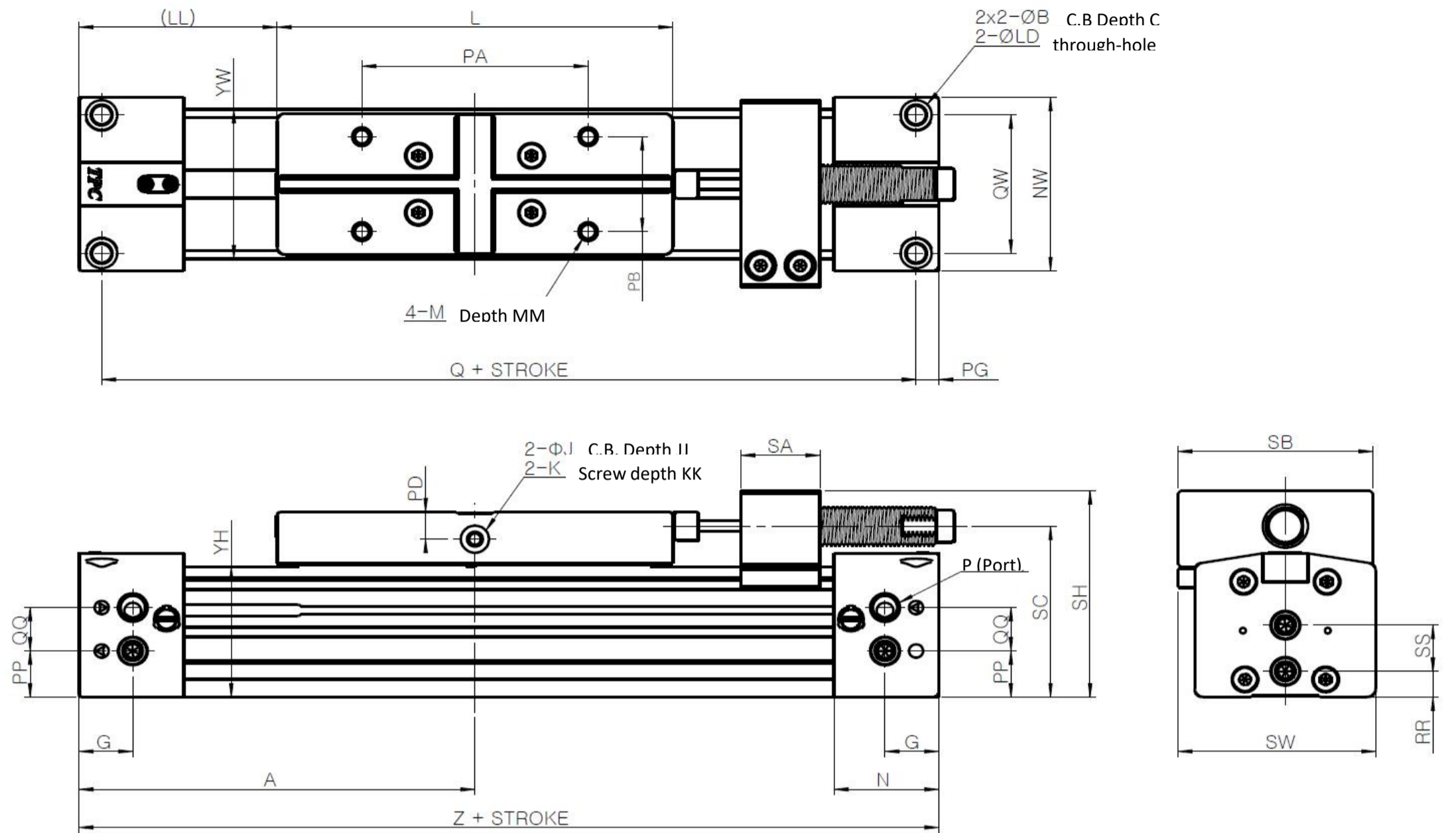

(Unit : mm)

Bore size	A	B	C	G	J	JJ	K	KK	L	LL	LD	M	MM	N	NW	P	PA
16	80	6	3	9	7	2	M4	8	80	40	3.5	M4	6	20	37	M5	40
20	100	7.5	4.5	12	8	2	M4	10	100	50	4.5	M5	8	25	45	M5	50
25	110	9	5.5	16	10	2	M5	9	110	55	5.6	M5	9	30	53	Rc 1/8	60
32	140	11	6.6	19	10	2	M5	10	140	70	6.8	M6	12	37	64	Rc 1/8	80
40	170	14	8.5	23	14	2	M6	13	170	85	8.6	M6	12	45	75	Rc 1/4	100

Bore size	PB	PD	PG	PP	Q	QQ	QW	RR	SA	SB	SC	SH	SS	SW	YH	YW	Z
16	20	4.5	3.5	7.2	153	9.5	30	3.5	20	42.5	34.5	40	11	43.5	26	35	160
20	25	5	4.5	10.5	191	11	36	7	20	48.5	42.5	50	11.5	50	32.5	40	200
25	30	6	7	12	206	16	42	8	25	56	46.3	60.5	16	57.5	38.5	46	220
32	35	10	8	17	264	16	51	9.5	28	69	63	76	17	70	48	55	280
40	40	12	9	18.5	322	24	59	12	28	78.5	76.8	90.5	21.8	80	60.5	67	340

Stroke Adjustment Unit Dimensions (Basic type, External guide type, LM guide type)

With adjustment bolt

APR Bore Size * - Stroke - A

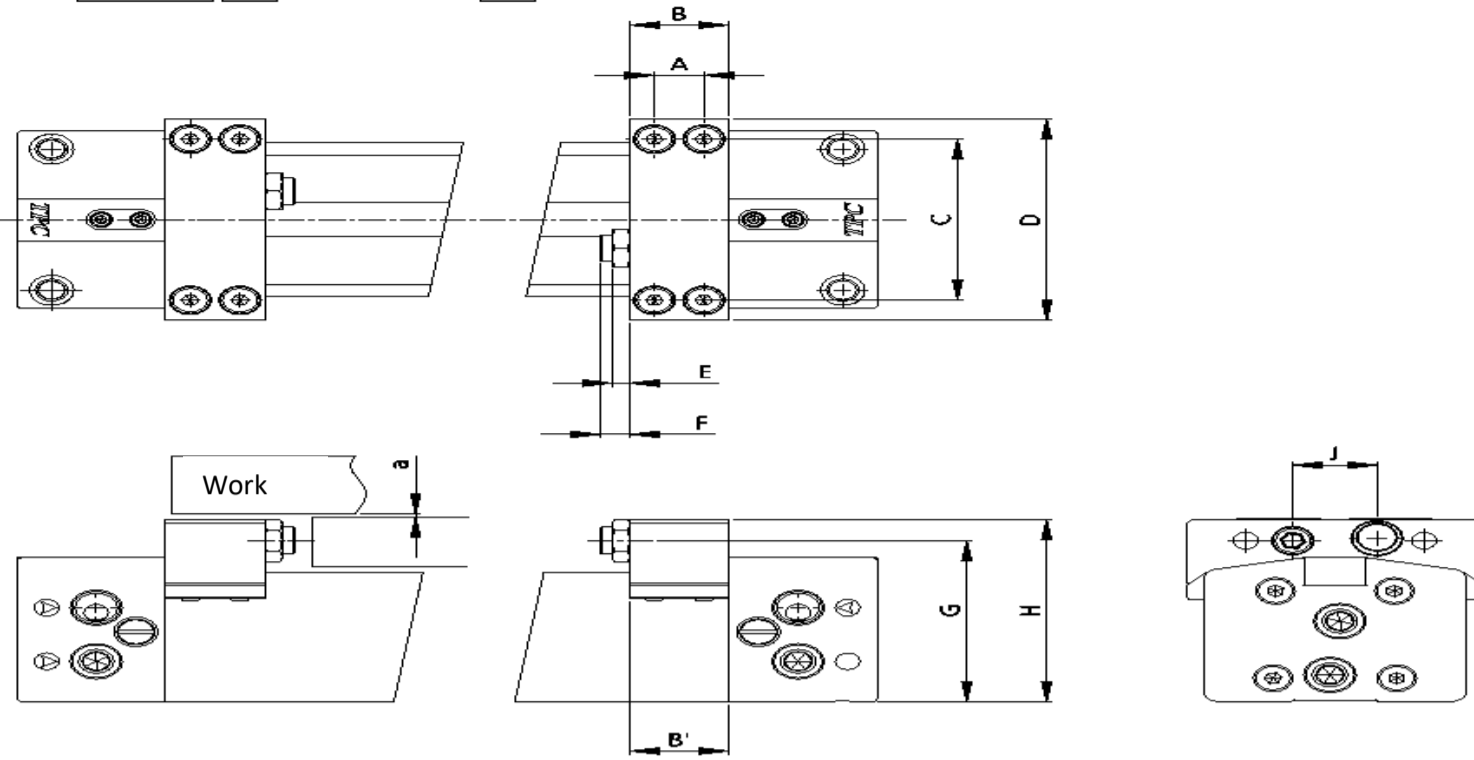

(Unit : mm)

Bore size	A	B	B'			C	D	E	F	G	H	J	a
			Standard	Short	Long								
16	7	14	14	19.6	25.2	34.4	43	2.4	5	35	40	11	4.2
20	9	19	19	25	31	43	53	3.2	6	42	46.3	14	1.5
25	10	20	20	31.5	43	48	60	3.5	6	48	54.2	17	1.5
32	13	25	25	37	49	60	74	4.5	7	61.7	69	22	2.3
40	17	31	31	47	63	78	94	4.5	9	76.3	83.8	22	1.5
50	20	40	40	60	80	95	115	5.5	9	88.5	100.3	28	6.8
63	28	52	52	77	102	116	140	5.5	9	109	120	35	4.5

※ When using a stroke adjustment unit, if the length of the workpiece exceeds the overall length of the slide table, allow a clearance of dimension "a" or larger on the workpiece side.

With low shock absorber + adjustment bolt

APR Bore Size * - Stroke - L

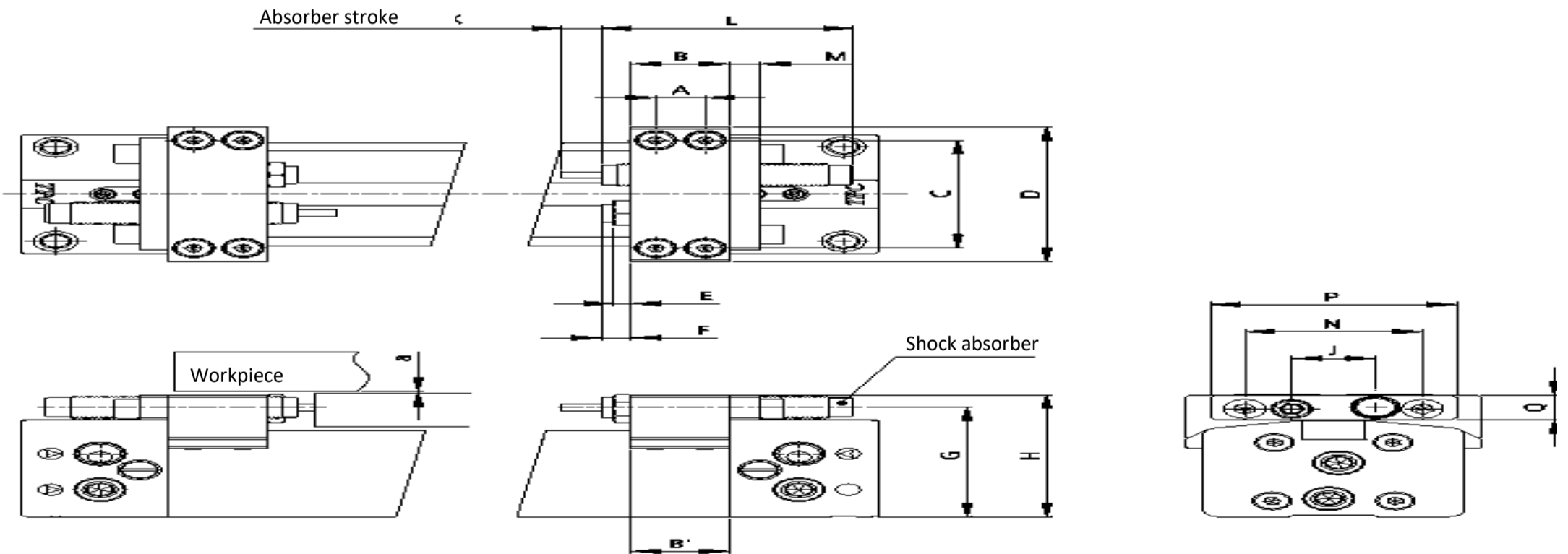

(Unit : mm)

Bore size	A	B	B'			C	D	E	F	G	H	J	K	L	M	N	P
			Standard	Short	Long												
16	7	14	14	19.6	25.2	34.4	43	2.4	5	35	40	11	6	41	5	26	35
20	9	19	19	25	31	43	53	3.2	6	41.5	46.3	14	6	41	5	30	38
25	10	20	20	31.5	43	48	60	3.5	6	48.7	54.2	17	8	51	6	36	50
32	13	25	25	37	49	60	74	4.5	7	61	69	22	15	75.5	6	45	56
40	17	31	31	47	63	78	94	4.5	9	75.3	83.8	22	15	75.5	6	50	65
50	20	40	40	60	80	95	115	5.5	9	89	100.3	28	20	85	6	43.5	85
63	28	52	52	77	102	116	140	5.5	9	108.8	120	35	20	85	8	52.5	95

Stroke Adjustment Unit Dimensions (Basic type, External guide type, LM guide type)

With high load shock absorber + Adjustment bolt

APR Bore Size * - Stroke - H

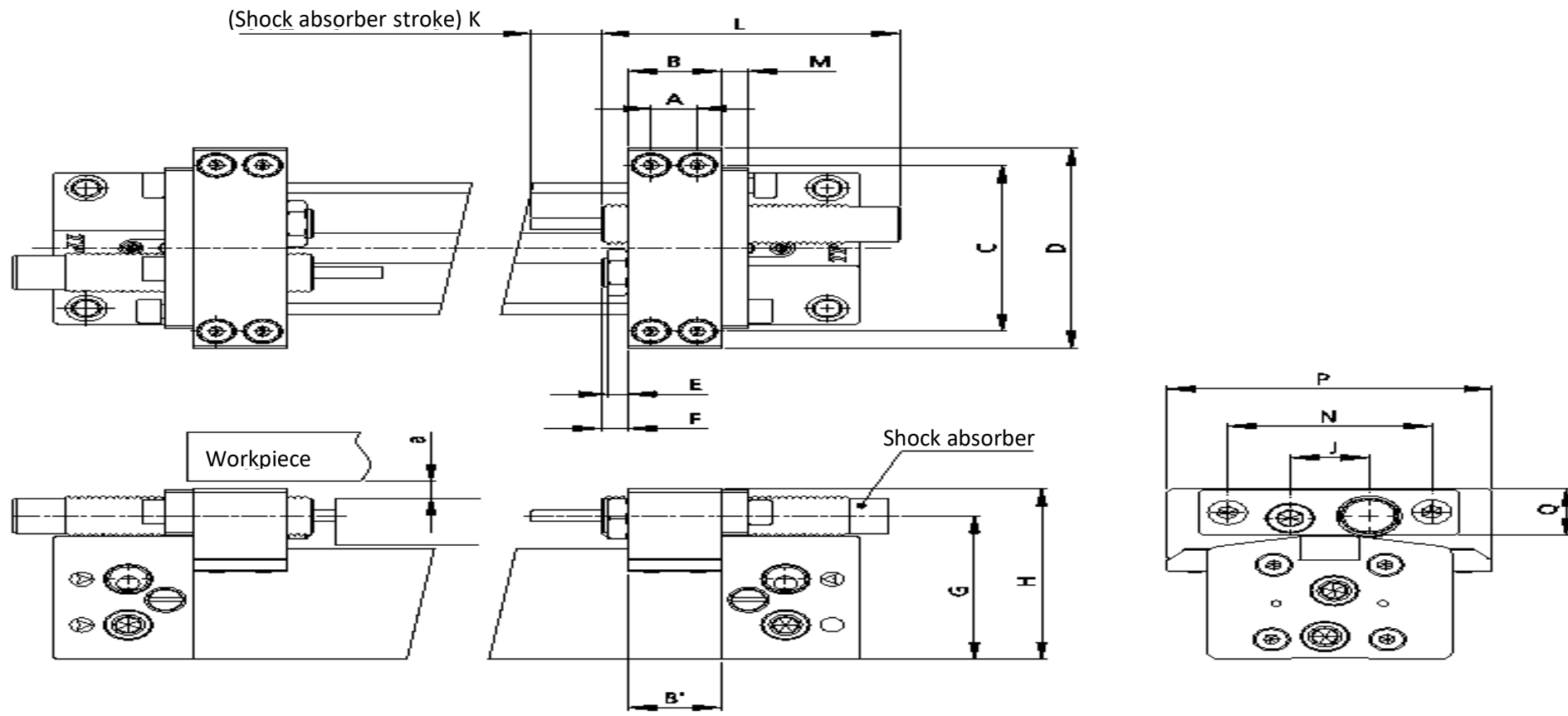

(Unit : mm)

Bore size	A	B	B'			C	D	E	F	G	H	J	K	L	M	N	P	Q	a
			Standard	Short	Long														
20	9	19	19	25	31	50	60	3.2	6	42	50	14	8	51	5	32	50	12.8	4.9
25	10	20	20	31.5	43	58	70	4.5	6	50	59.5	17	15	64.5	6	44	56	16.2	6.5
32	13	25	25	37	49	76	90	5.5	8	64.6	77	22	20	85	6	56	65	23.6	10.3
40	17	31	31	47	63	84	100	5.5	9	76.7	88	22	20	85	6	60	74	22.3	5.2
50	20	40	40	60	80	100	120	5.5	9	90.5	108.5	28	25	100	6	44	90	28.3	15
63	28	52	52	77	102	126	150	5.5	9	111.7	128	35	25	100	8	57.5	100	27.3	12.5

※ When using a stroke adjustment unit, if the length of the workpiece exceeds the overall length of the slide table, allow a clearance of dimension "a" or larger on the workpiece side.

APR Series

Dimensions of Stroke Adjustment Unit (Standard type, outer guide type, LM guide type)

Low load shock absorber + adjustment bolt

APR Bore Size * - Stroke - L

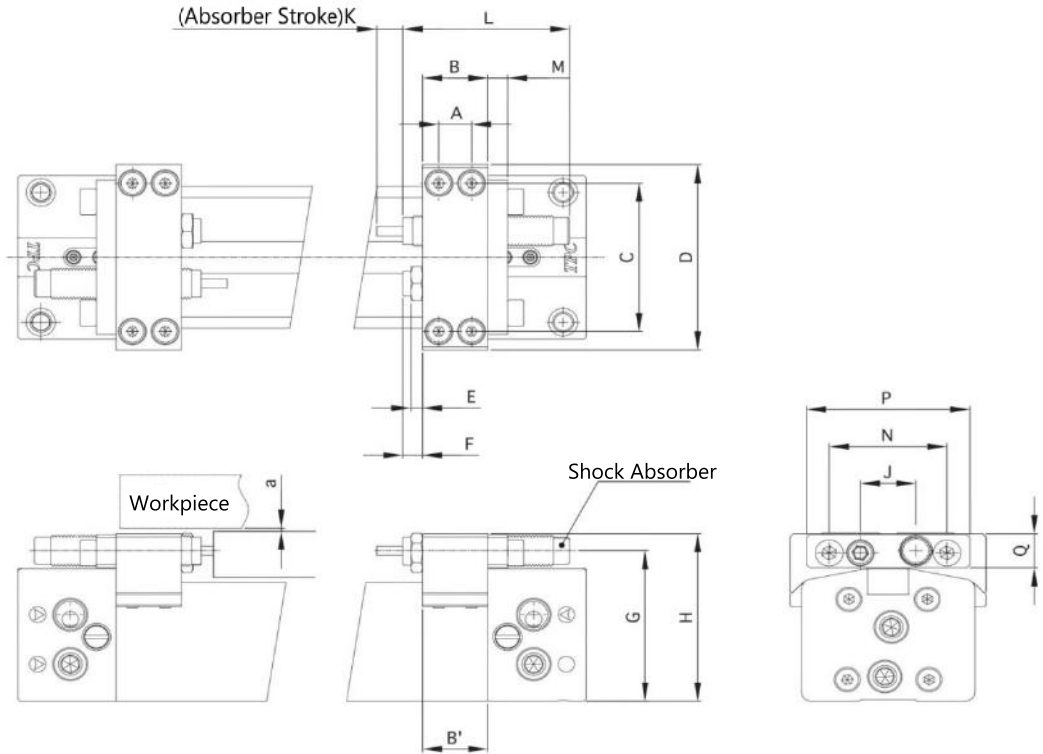

(Unit : mm)

Bore Size	A	B	B'			C	D	E	F	G	H	J	K	L	M	N	P	Q	a
			Standard	Short	Long														
16	7	14	14	19.6	25.2	34.4	43	2.4	5	35	40	11	6	41	5	26	35	9.8	4.2
20	9	19	19	25	31	43	53	3.2	6	41.5	46.3	14	6	41	5	30	38	9.3	1.5
25	10	20	20	31.5	43	48	80	3.5	6	48.7	54.2	17	8	51	6	36	50	11	1.5
32	13	25	25	37	49	60	74	4.5	7	61	69	22	15	75.5	6	45	56	15.8	2.3
40	17	31	31	47	63	78	94	4.5	9	75.3	83.8	22	15	75.5	6	50	65	18.1	1.5
50	20	40	40	60	80	95	115	5.5	9	89	100.3	28	20	85	6	43.5	85	20.1	6.8
63	28	52	52	77	102	116	140	5.5	9	108.8	120	35	20	85	8	52.5	95	19.3	4.5

※ When using a stroke adjustment unit, if the length of the workpiece exceeds the overall length of the slide table, allow a clearance of dimension "a" or larger on the workpiece side.

Side Bracket (Standard type, external guide type)

Side Bracket A

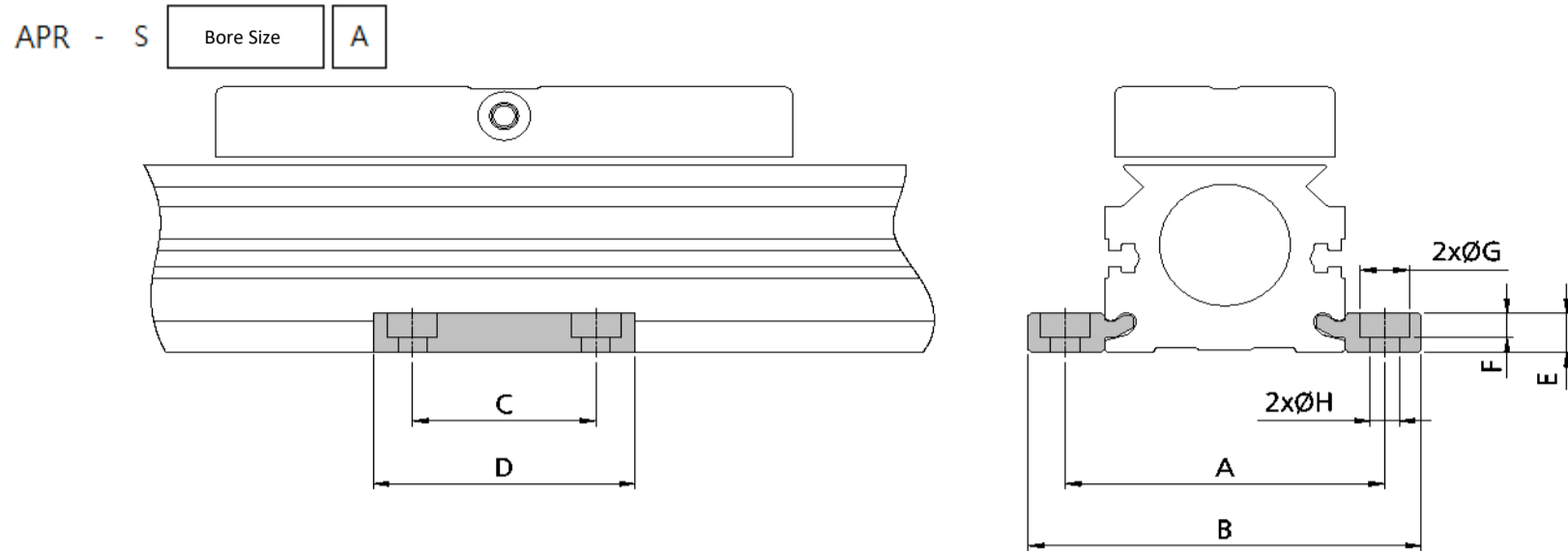

Side Bracket B

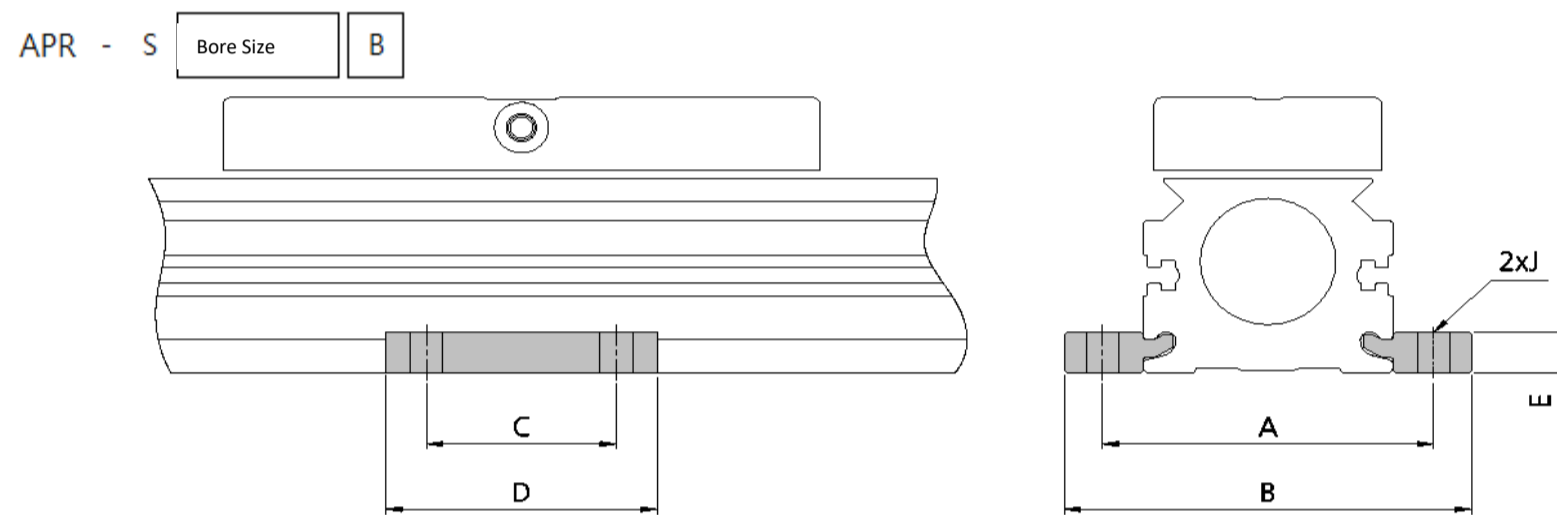

(Unit : mm)

Bore size	A	B	C	D	E	F	G	H	J
16	44	53.6	15	26	5	3	6.5	3.4	M4x0.7
20	53	65.6	25	38	7	4	8	4.5	M5x0.8
25	61	75	35	50	8	5	9.5	5.5	M6x1.0
32	70	84	35	50	8	5	9.5	5.5	M6x1.0
40	87	105	45	64	11.7	6	11	6.6	M8x1.25
50	113	131	45	64	11.7	6	11	6.6	M8x1.25
63	136	158	55	80	14.8	8.5	14	9	M10x1.5

※ A set of side brackets consists of a left bracket and a right bracket.

Guide for Side Bracket Application

※ When used with a long stroke, the cylinder tube may be bent depending on its own weight or load.

In such a case, ensure that the support distance (L) shown in the right figure is less than the graph value to support the middle position with the side bracket.

※ If the distance between the counterparts is incorrect during the installation of the cylinder tube, trouble may occur due to the mounting of the side brackets.

Also, when using long strokes involving vibration and impact, it is recommended to use the side brackets even if the spacing value is within the permissible range shown in the graph.

※ The side bracket is not for mounting and can only be used for support purposes.

※ A set of side brackets consists of a left bracket and a right bracket.

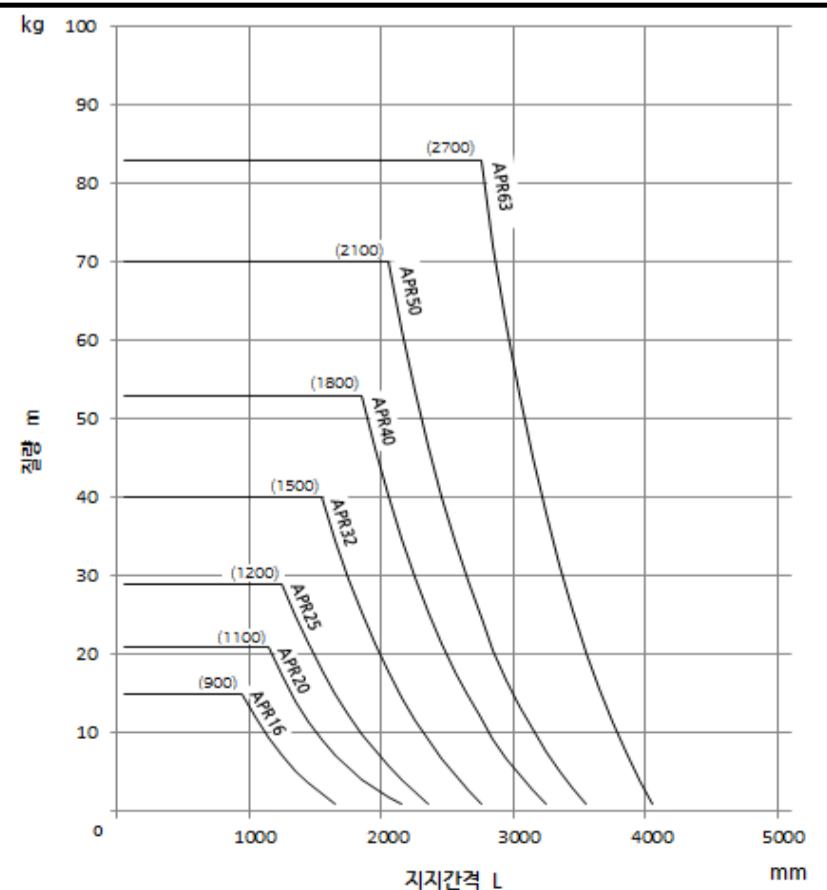
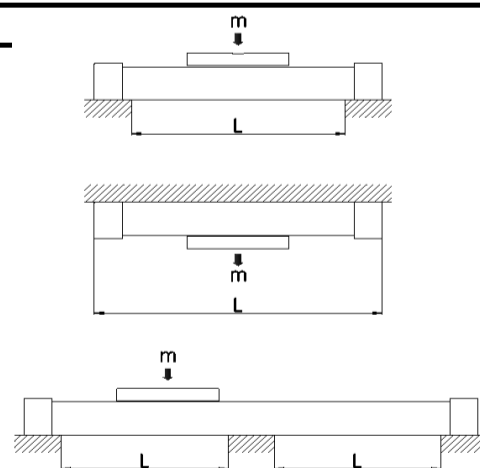

Floating Bracket (Basic type)

APR - J Bore Size

Ø16, 20, 50, 63

(Application Example)

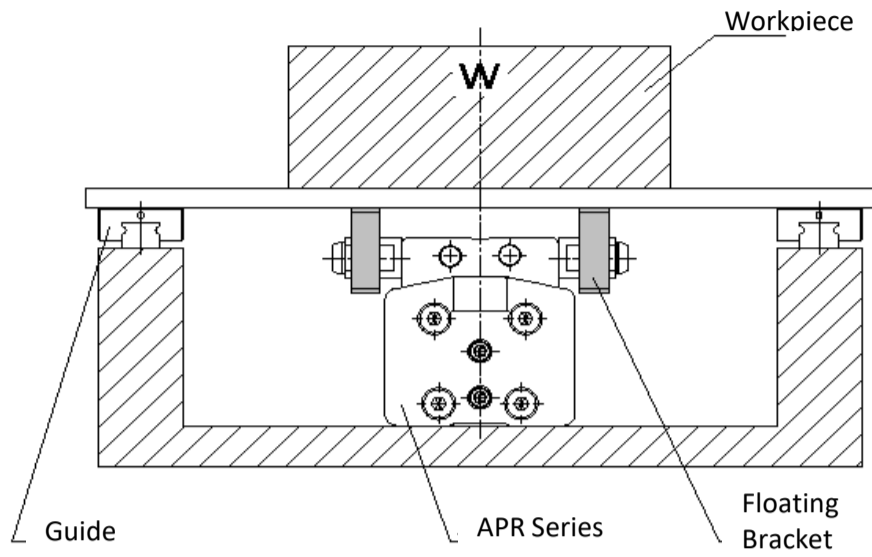

(Dimensions)

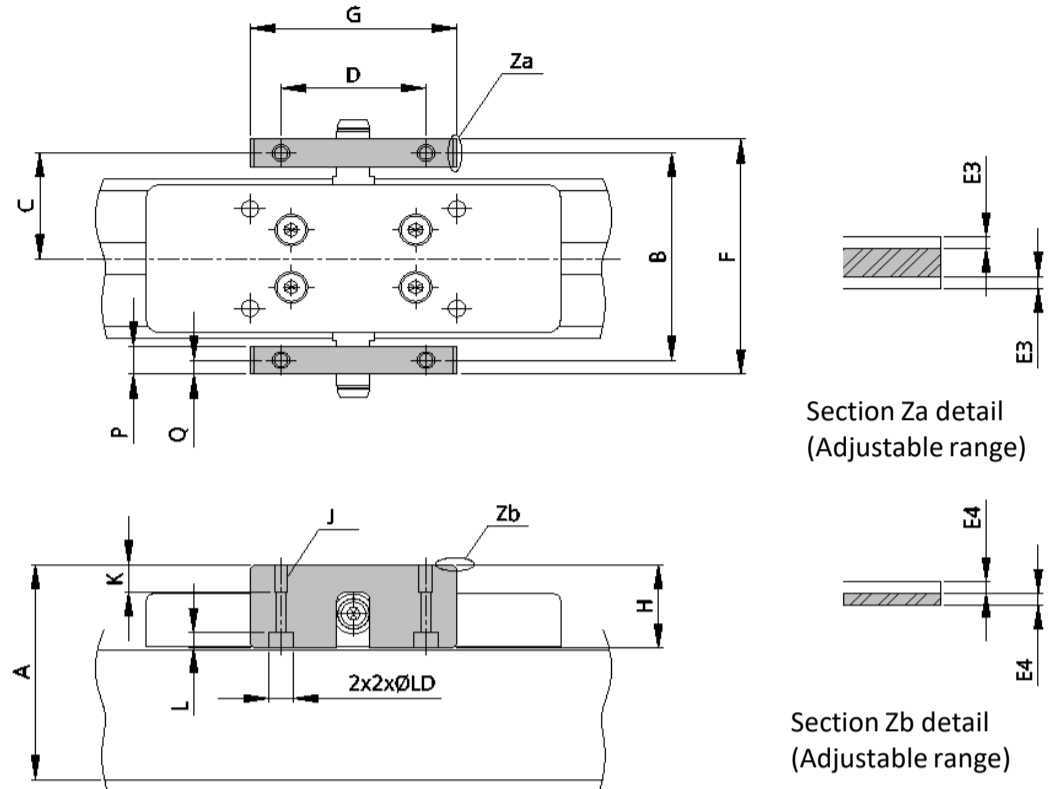

(Unit : mm)

Bore size	A	B	C	D	F	G	H	J	K	L	LD	P	Q	E3	E4
16	45	45	22.5	30	52	38	18	M4x0.7	10	4	6	7	3.5	1	1
20	55	52	26	35	59	50	21	M4x0.7	10	4	6	7	3.5	1	1
50	110	110	55	70	126	90	36	M8x1.25	16	6.5	11	16	8	2.5	2.5
63	131	130	65	80	149	100	40	M10x1.5	20	9	14	19	9.5	2.5	2.5

Ø25, 32, 40

(Application Example)

(Dimensions)

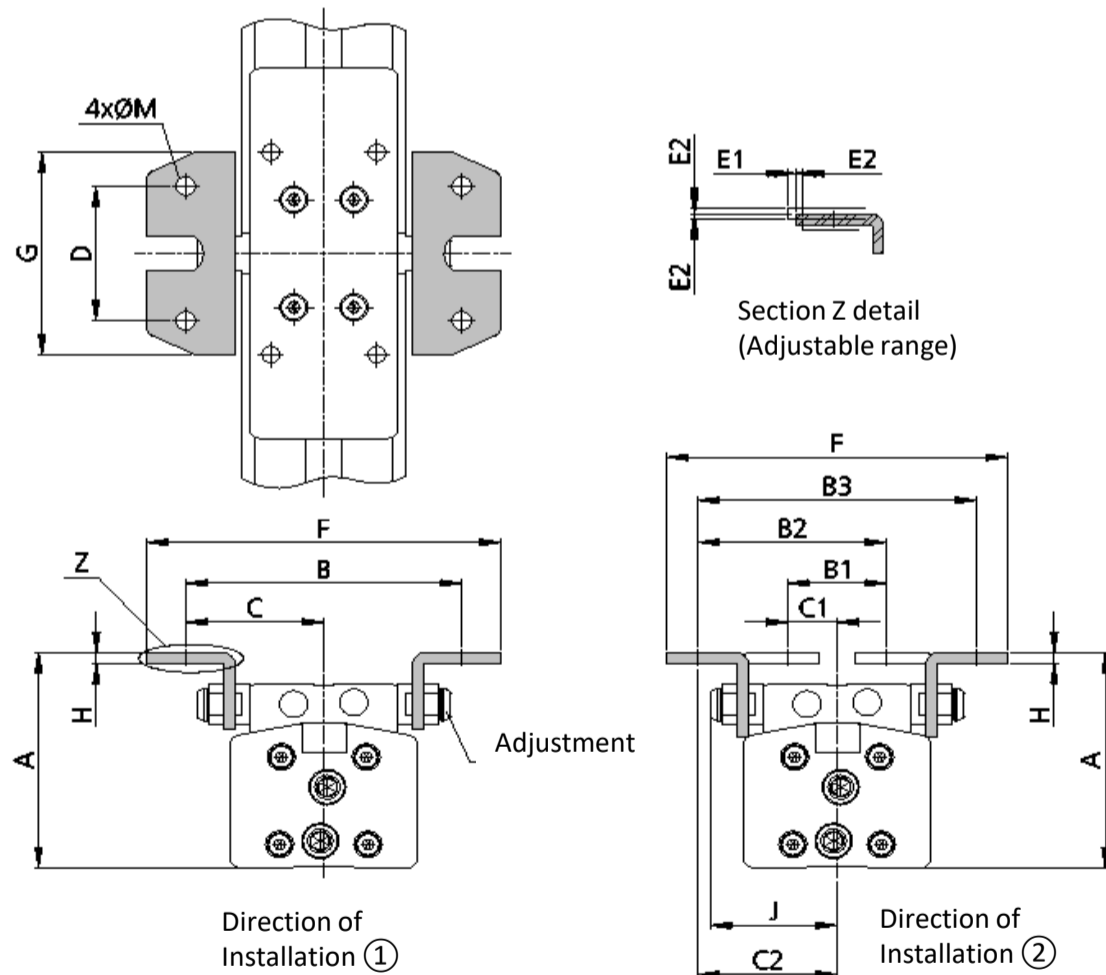
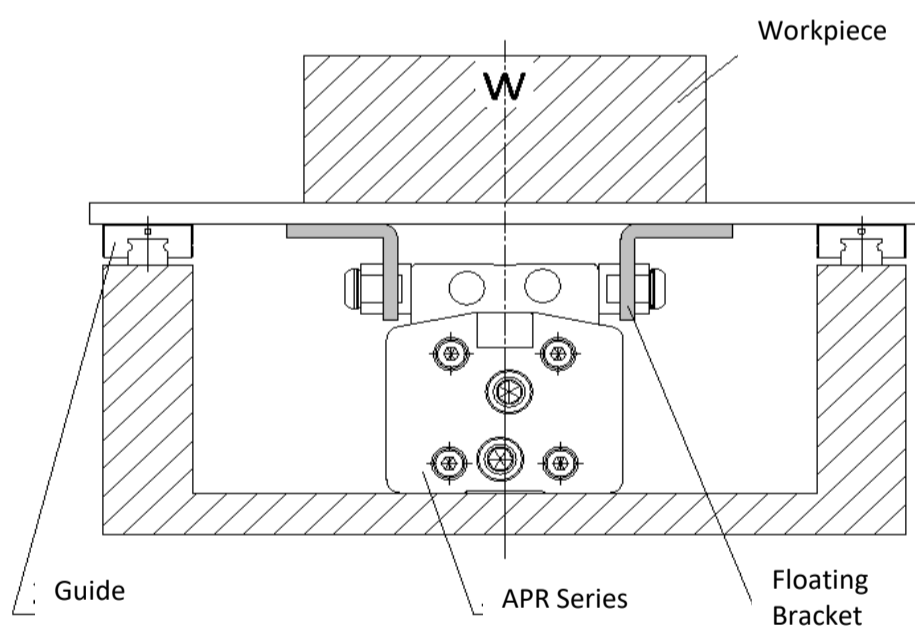

(Unit : mm)

Bore size	Common					Direction of installation ①				Direction of installation ②							Adjustment Range	
	D	G	H	J	M	A	B	C	F	A	B1	B2	B3	C1	C2	F	E1	E2
25	40	60	3.2	35	5.5	63	78	39	100	65	28	53	78	14	39	96	1	1
32	55	80	4.5	40	6.5	76	94	47	124	82	40	64	88	20	44	111	1	1
40	74	100	4.5	47.3	6.5	92	112	56	144	98	44	76	108	22	54	131	1	1

※ Floating brackets are only applicable for basic types.

※ A set of brackets with the floating mechanism consists of a left bracket and a right bracket.

Cylinder Model Selection

Maximum Allowable Moment • Maximum Load Mass

Model	Bore size (mm)	Max. allowable moment (N • m)			Max. load mass (N)		
		M_x	M_y	M_z	F_x	F_y	F_z
APR-A (Internal guide type)	16	0.3	3.8	1.1	150	40	120
	20	0.8	11	3.2	320	80	250
	25	1.2	16	4.6	480	100	310
	32	2.4	26	8.0	660	130	400
	40	4.8	62	18	1130	240	730
	50	8.3	90	26	1420	330	990
	63	12	146	43	1760	420	1210
APR-B (External guide type)	16	2	5.5		240		200
	20	5.4	16		490		420
	25	7.4	23		640		480
	32	14	34		840		620
	40	29	81		1300		1170
	50	49	120		1800		1500
	63	73	210		2500		1940
APR-C (LM guide type)	16	3.7	4.9			200	
	20	8.8	13			450	
	25	18	21			625	
	32	31	40			825	
	40	39	51			1650	

The above values show the allowable moment and allowable load values that can be applied at a speed of 0.2 m / s or less.
For the values of the piston speed, refer to the graph.

[Example]

Load weight $M_0 = 10\text{kg}$

Speed $V = 0.5\text{m/s}$

Load center position $S1 = 100\text{mm}$

$S2 = 100\text{mm}$

The above example shows an example of calculation for checking the cushioning ability when selecting the cylinder bore size in the cylinder selection method.

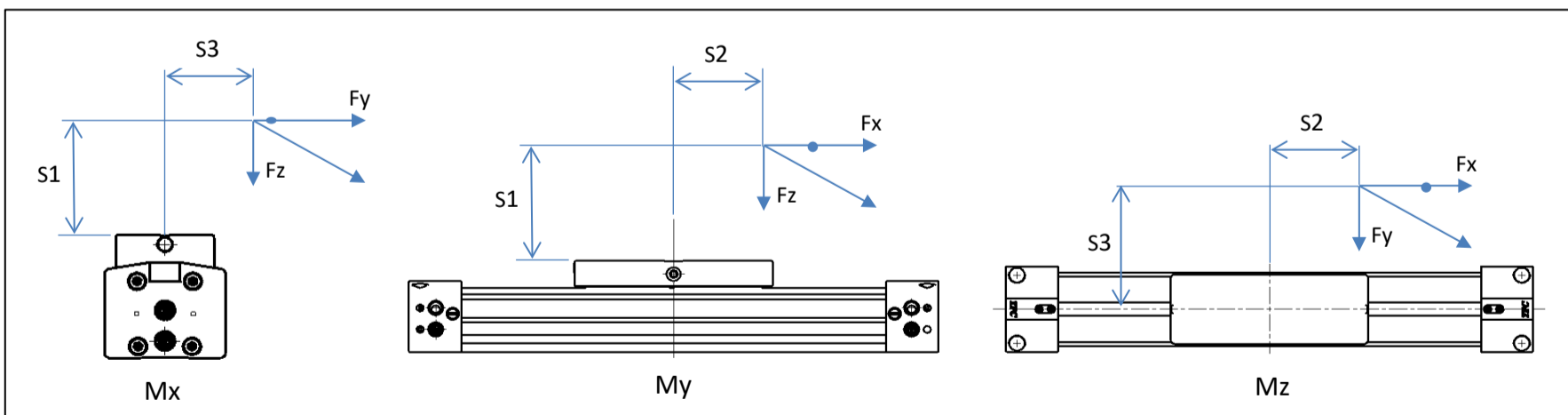

Cylinder Selection Method

Selection of tube bore size

- ① Calculation of load
Find FZ from load weight to M0.
 $Fz = M0 \times g = M0 \times 9.81$
- ② Static moment calculation
 $Mx = Fz \times S3 \text{ (N} \cdot \text{m)}$
 $My = Fz \times S2 \text{ (N} \cdot \text{m)}$
- ③ Total moment calculation
 $MG = Mx + My \text{ (N} \cdot \text{m)}$
- ④ Calculate required moment
The total moment MG is doubled.
 $MN = MG \times 2 \text{ (N} \cdot \text{m)}$
- ⑤ Selection of cylinder bore size
Select the bore size of the calculated total moment MN that is close to the allowable moment MY.

[Example of calculation]

- ① $Fz = 10 \times 9.81 = 98\text{(N)}$
- ② $Mx = 98 \times 0.05 = 4.9\text{(N} \cdot \text{m)}$
 $My = 98 \times 0.10 = 9.8\text{(N} \cdot \text{m)}$
- ③ $MG = 4.9 + 9.8 = 14.7\text{(N} \cdot \text{m)}$
- ④ $MN = 14.7 \times 2 = 29.4\text{(N} \cdot \text{m)}$
- ⑤ Cylinder bore size
APR-A (Internal guide type)
 $\text{Ø}40\text{(}M_y = 62\text{N} \cdot \text{m)}$
APR-B (External guide type)
 $\text{Ø}40\text{(}M_y = 81\text{N} \cdot \text{m)}$
APR-C (LM guide type)

Allowable Moment

Check the static moment and the dynamic moment according to the selected cylinder and load zone.

1. Static moment

- ① With respect to the static moment MX, the allowable load FZ max (X1) of S3 in the following Table 1 is obtained.
 $Fz \text{ max}(X) = K1 \times Fz \text{ max}(X1)$

[Example of calculation]

For APR-B(External guide type),

- ① For the static moment MY, the allowable load FZ max (Y1) of S2 in Table 2 below is obtained.
 $Fz \text{ max}(Y) = K2 \times Fz \text{ max}(Y1)$

[Example of calculation]

For APR-B(External guide type),

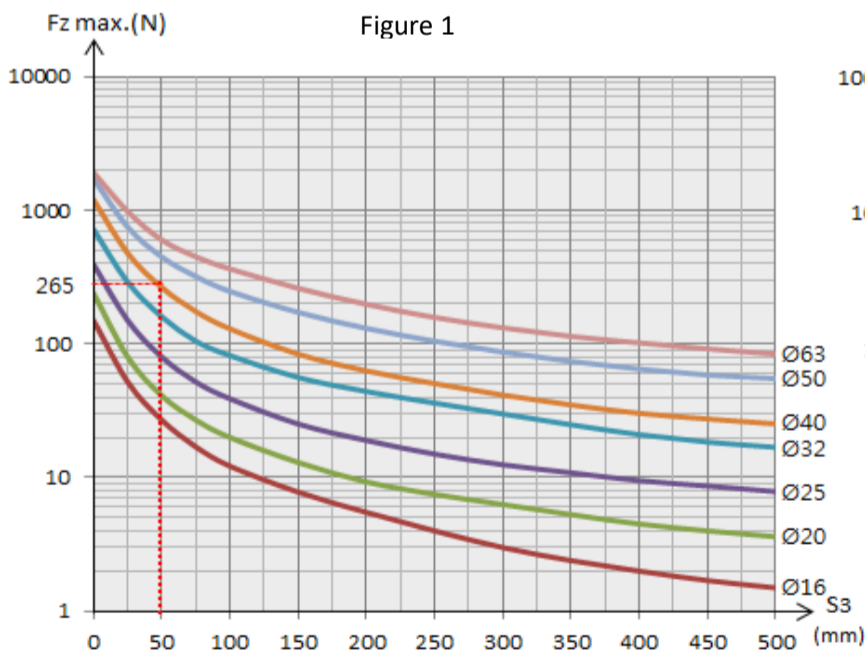

Figure 1

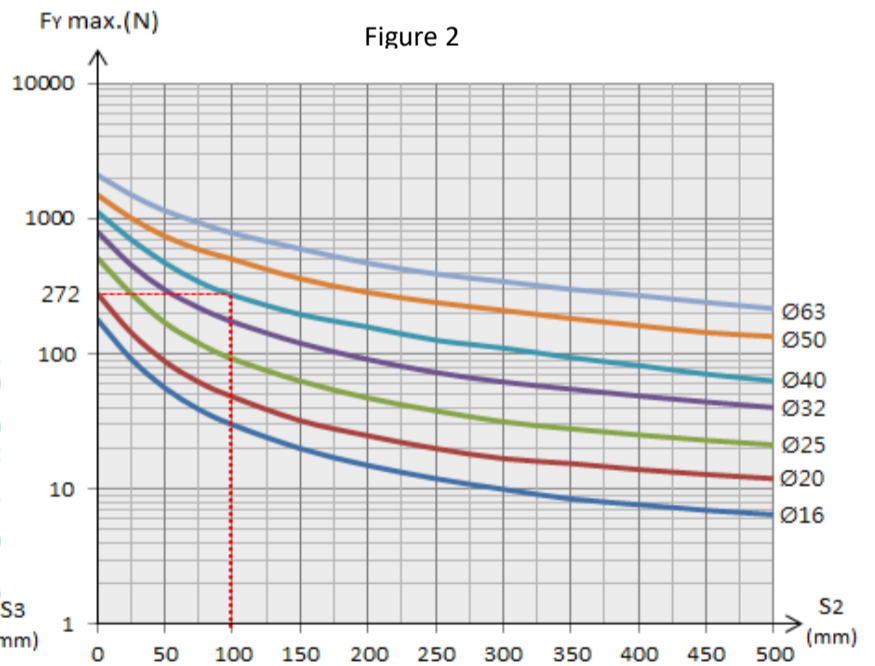

Figure 2

Cylinder	K1
APR-A	0.5
APR-B	1
APR-C	1.5

Cylinder	S2(mm)	K2	Cylinder	K2
APR-A	0~20	0.6	APR-B	1
	20~40	0.5		
	40~60	0.4		
	60~80	0.3	APR-C	1.5
80	0.2			

Cylinder Selection Method

Allowable Moment

1. Dynamic moment

- ① With respect to the dynamic moment MZ, the allowable load Fx max (Z1) of S3 in Table 3 is obtained.

$$F_{x \max}(X) = K3 \times F_{x \max}(X1)$$

[Example of calculation]

For APR-B(external guide type)

- ② For the dynamic moment MY, the allowable load Fx max (Y1) of S1 in Table 3 is obtained.

$$F_{x \max}(Y) = K3 \times F_{x \max}(Y1)$$

[Example of calculation]

For APR-B(external guide type)

- ③ Calculate the speed V, the load M0, the cylinder bore size (in cushion Sm), and the load Fdyn at rest to the end of stroke, in accordance with Table 4.

$$F_{dyn} = \frac{M_0 \times V^2}{2S} \text{ (N)}$$

[Example of calculation]

$$F_{dyn} = \frac{10 \times 0.5^2}{2 \times 57 \times 0.001} = 22 \text{ (N)}$$

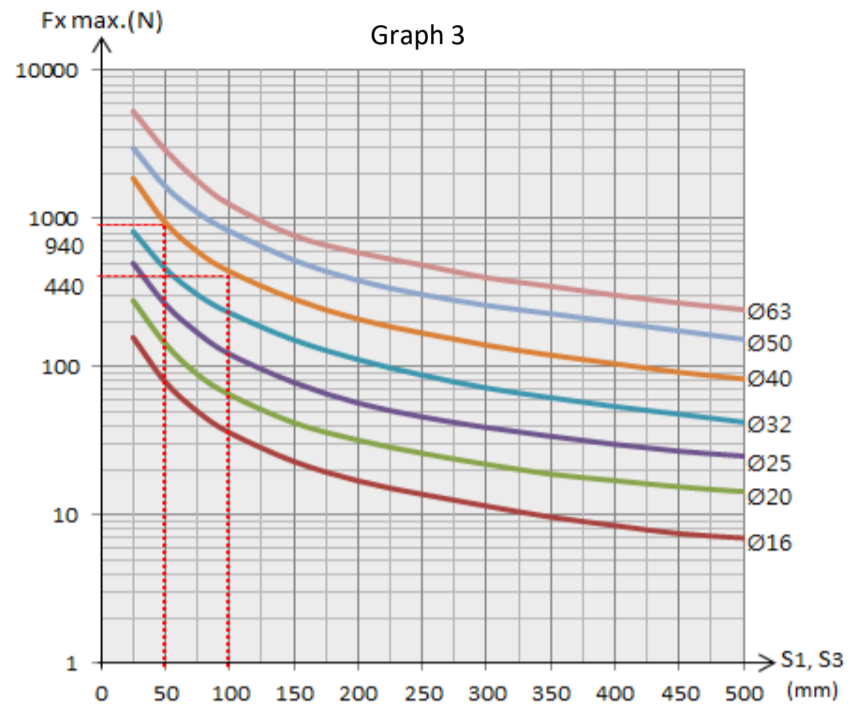

Cylinder	K3
APR-A	0.5
APR-B	1
APR-C	1.5

Cushion Length (mm)	
Bore size	Cushion length(S)
16	11.5
20	27
25	32
32	40
40	57
50	60
63	65

Sum of Guide Load Factors

3. Calculate% of the allowable values of static load (Fz) and dynamic load (Fvdn) respectively

$$\eta_1 = \frac{F_z}{F_{z \max}(X)} \times 100(\%)$$

$$\eta_2 = \frac{F_z}{F_{y \max}(Y)} \times 100(\%)$$

$$\eta_3 = \frac{F_{dyn}}{F_{x \max}(X)} \times 100(\%)$$

$$\eta_4 = \frac{F_{dyn}}{F_{y \max}(Y)} \times 100(\%)$$

[Calculation example]

$$\eta_1 = \frac{98}{265} \times 100 = 37(\%)$$

$$\eta_2 = \frac{98}{272} \times 100 = 36(\%)$$

$$\eta_3 = \frac{22}{940} \times 100 = 2(\%)$$

$$\eta_4 = \frac{22}{440} \times 100 = 5(\%)$$

$$\eta_1 + \eta_2 + \eta_3 + \eta_4 = 37 + 36 + 2 + 5 = 80$$

3. Combine the values from the above equation to see

Combine the values from the above equation to see if the value does not exceed 100.

If it exceeds 100%, increase the cylinder bore size, or check the allowable moment again with the LM guide type.

$$\eta_1 + \eta_2 + \eta_3 + \eta_4 \leq 100(\%)$$

Cylinder Selection Method

Cushion Capacity

In Table 5, determine the operating speed V , the allowable weight M_{max} of the cylinder bore D , and check whether the load weight M_0 does not exceed M_{max} .

If M_0 exceeds M_{max} , increase the cylinder bore size and install a shock absorber on the outside.

[Example of calculation

Speed $V = 0.5\text{m/s}$, cylinder bore size is $\text{Ø}40$ Since $M_{max} = 127\text{kg}$, does not exceed $M_0 = 10\text{kg}$.

