

# AMR Series

Magnet type rodless cylinder / Bore size: Ø10, Ø16, Ø20, Ø25, Ø32, Ø40, Ø50

Actuator  
Cylinder

AMR Series

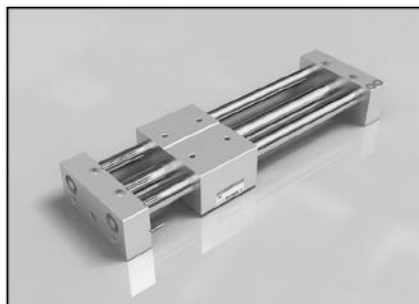

- Precision stainless steel body for smooth actuation
- Light weight
- Compact design
- Leak free
- Non - lubricated type standard
- Position sensing capable with guide type(G)

## How to order

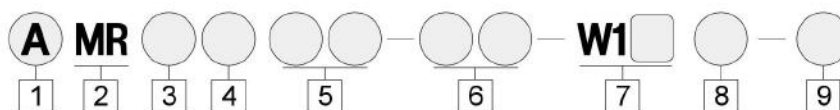

### 1 Actuator

### 2 Magnet type rodless cylinder

### 3 Type of bearing

- B : Basic type(Standard)  
 G : With guide type  
 (Auto switch capable cylinder)  
 L : Foot type

### 4 Magnet holding power(kgf)

Dia	H	L
Ø10	5,5	-
Ø16	12	-
Ø20	24	15,7
Ø25	37	22,5
Ø32	60	36,5
Ø40	94	58
Ø50	150	-

### 5 Bore size

Bore size		6 Stroke(mm)	
No.	Size	AMRB	AMRG
10	Ø10	50~500mm	50~500mm
16	Ø16	50~500mm	50~700mm
20	Ø20	100~1,500mm	100~1,000mm
25	Ø25	100~1,500mm	100~1,500mm
32	Ø32	100~2,000mm	100~1,500mm
40	Ø40	100~2,000mm	100~1,500mm
50	Ø50	100~2,000mm	-

### 7 Auto switches

- Blank : None  
 W13 : 2-Wire(AC100V, DC24V)  
 WIH : 3-Wire(DC24V)

### 8 Lead wire of auto switches



- Blank : 0,5M  
 L : 3M

### 9 Number of switches

- Blank : 2 pcs  
 S : 1 pc  
 N : N pcs

## Specifications

Fluid	Air		
Proof pressure	1,05MPa(10,5kgf/cm <sup>2</sup> )		
Max. operating pressure	0,7MPa(7kgf/cm <sup>2</sup> )		
Min. operating pressure	0,2MPa(2kgf/cm <sup>2</sup> )		
Ambient & fluid temperature	5 ~ 60°C		
Lubrication	Non-lube		
Operating piston speed	150 ~ 400/sec		
Cushion	Basic type	Ø10, Ø16	Rubber cushion
		Ø25, Ø32, Ø40, Ø50	Air cushion
	With Guide type	Ø10, Ø16, Ø20, Ø25, Ø32, Ø40	Rubber /Air cushion

Action	Series	Bore size (mm)	Port size		Standard stroke		Operating pressure kgf/cm <sup>2</sup> (psi)
			AMR	UAMR	AMR(mm)	UAMR(inch)	
Double acting/ Ball bushing bearing type 	(U)AMRB	Ø10	M5 x 0,8	10-32 UNF	50~500	0,5~12	1,5~7 (21~100)
		Ø16					
		Ø20	Rc(PT)1/8	NPT 1/8	100~1,500	0,5~60	
		Ø25					
		Ø32	Rc(PT)1/4	NPT 1/4	100~2,000	0,5~78	
		Ø40					
Ø50							
Double acting/ Sliding bearing type 	(U)AMRG	Ø10	M5 x 0,8	10-32 UNF	50~500	0,5~20	1,5~7 (21~100)
		Ø16					
		Ø20	Rc(PT) 1/8	NPT 1/8	100~1,000	0,5~40	
		Ø25					
		Ø32	Rc(PT) 1/4	NPT 1/4	100~1,500	0,5~60	
		Ø40					

# Series AMR

## Specifications

Fluid	Air	
Proof pressure	1.03MPa (149psi)	
Max. operating pressure	0.7MPa (9psi)	
Min. operating pressure	0.2MPa (28psi)	
Ambient and fluid temperature	5 ~ 60°C (41 ~ 140°F)	
Operating piston speed	50 ~ 400 mm/s	
Cushion	Rubber cushion at both sides	
Lubrication	Non-lube	
Cushion type	AMRB10, AMRB16	Rubber cushion
	AMRB20, AMRB25	Air cushion
	AMRB32, AMRB40, AMRB50	
	AMRG10, AMRG16, AMRG20	Rubber cushion
	AMRG25, AMRG32, AMRG40	

## Cylinder Theoretical Output

ø 10

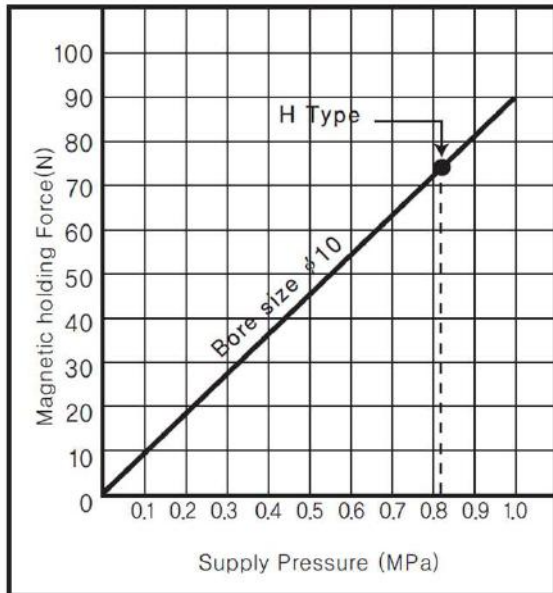

ø 16, ø 20, ø 25, ø 32, ø 40, ø 50

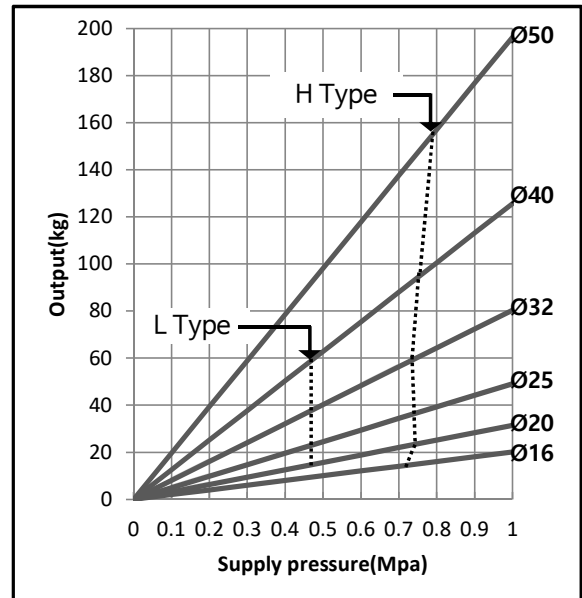

## Weight Table

No. of Magnets	Bore Size						
	ø 10	ø 16	ø 20	ø 25	ø 32	ø 40	
Basic Weight	AMROH	0.08(0.17)	0.30(0.62)	0.37	0.71(1.56)	1.34(2.95)	2.15(4.74)
	AMROL	-	-	0.26	0.62(2.62)	1.19(4.34)	1.97(6.83)
Additional weight per 50 stroke		0.014(0.03)	0.02(0.04)	0.04	0.05(0.11)	0.07(0.15)	0.08(0.17)

Calculation method/Example : AMRB32-0400

Basic weight ..... 1.34kg  
 Additional weight ... 0.07/50s } 1.34 + 0.07 × 20 ÷ 2 = 2.04kg  
 Cylinder stroke ..... 500st

## Main Parts

Description	Material	Note
Head cover	Aluminium alloy	Colored hard alumite
Cylinder tube	Stainless steel	
Body	Aluminium alloy	Colored hard alumite
Magnet	Rare earth magnet	

# Series AMR

## Basic Type:Construction/Parts List

AMRBH  $\phi$  10,  $\phi$  16

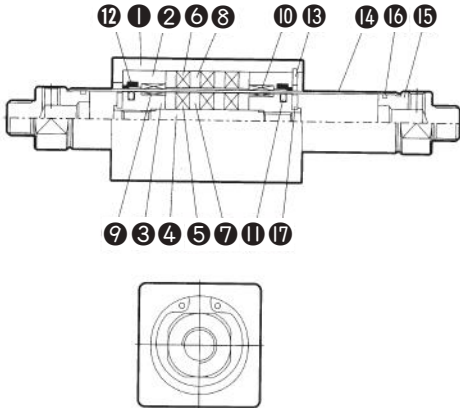

No.	Description	Material	Note
1	Slider	Aluminum alloy	White Alumite
2	Holder	Aluminum alloy	"
3	Piston	Aluminum alloy	Zinc Chromate
4	Shaft	Stainless steel	
5	Inner Magnet	-	Nickel Plated
6	Outer Magnet	-	"
7	Inner Yoke	Carbon steel	
8	Outer Yoke	Carbon steel	
9	Inner Wear Ring	Resin	
10	Outer Wear Ring	Resin	
11	Piston Packing	NBR	
12	Wiper Ring	NBR	
13	Snap Ring	Spring	
14	Cylinder Tube	Stainless steel	
15	End Cover	Aluminum alloy	
16	Tube Gasket	NBR	
17	Bumper	Urethane	

AMRBH  $\phi$  20,  $\phi$  25,  $\phi$  32,  $\phi$  40

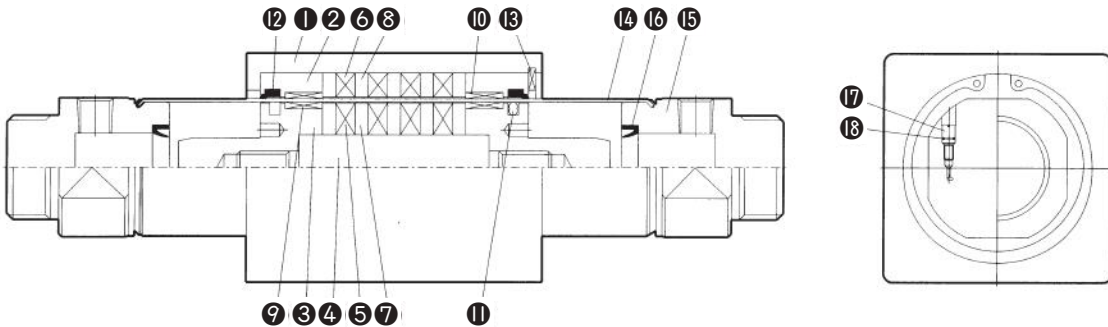

No.	Description	Material	Note
1	Slider	Aluminum alloy	White Alumite
2	Holder	Aluminum alloy	"
3	Piston	Aluminum alloy	Zinc chromate
4	Shaft	Stainless steel	
5	Inner Magnet	-	Nicke Plated
6	Outer Magnet	-	"
7	Inner Yoke	Carbon steel	Zinc chromate
8	Outer Yoke	Carbon steel	"
9	Inner Wear Ring	Resin	
10	Outer Wear Ring	Resin	
11	Piston Packing	NBR	
12	Wiper Ring	NBR	

No.	Description	Material	Note
13	Snap Ring	Spring steel	
14	Cylinder Tube	Stainless steel	
15	End Cover	Aluminum alloy	Hard Alumite
16	Cushion Packing	NBR	
17	Cushion Valve	Carbon steel	
18	Cushion Valve O-Ring	NBR	

- ACP
- APM
- AS
- AX
- AM2
- AM
- AL
- ALX
- AQ
- ADQ
- AQ2
- ADQ2
- AJ
- AJM
- ABK
- ACK1
- NSK
- AG
- NGQ
- AGX
- GX
- NP
- ADR
- AMR**
- NDM
- ARD
- NST
- AST
- ASTH
- NLCD
- NLCS

## Basic Type : Construction/Parts List

AMRBH  $\phi$ 50

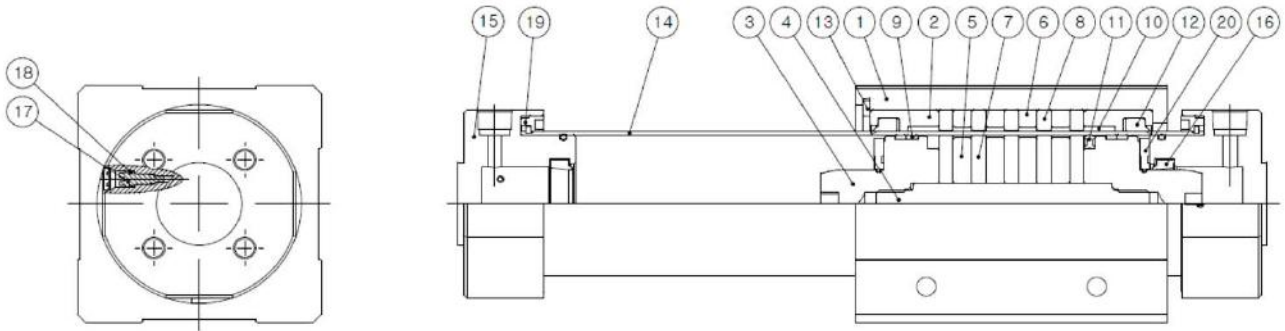

NO.	PARTS	MATEIRAL	QTY	REMARKS
1	SLIDER	Aluminium alloy	1	White Alumite
2	HOLDER	Aluminium alloy	2	White Alumite
3	PISTON	Aluminium alloy	2	Zinc Chromate
4	SHAFT	Stainless steel	1	
5	INNER MAGNET	Rare earth magnet	4	Nickel-plated
6	OUTER MAGNET	Rare earth magnet	4	Nickel-plated
7	INNER YOKE	Carbon steel	5	Nickel-plated
8	OUTER YOKE	Carbon steel	5	Nickel-plated
9	INNER WEARING	Resin	4	
10	OUTER WEARING	Resin	2	

NO.	PARTS	MATEIRAL	QTY	REMARKS
11	PISTON PACKING	NBR	1	
12	WIPER RING	NBR	2	
13	SNAP RING	Carbon steel	1	
14	CYLINDER TUBE	Stainless steel	1	
15	END COVER	Aluminium alloy	2	White Alumite
16	CUSHION PACKING	NBR	2	
17	CUSHION VALVE	Carbon steel	2	
18	CUSHION VALVE O-RING	NBR	2	
19	RING PLATE	Aluminium alloy	2	White Alumite
20	BUMPER	Urethane	2	

# Series AMR

## Basic Type : Construction/Parts List

AMRBL  $\phi 20, \phi 25,$   
 $\phi 32, \phi 40$

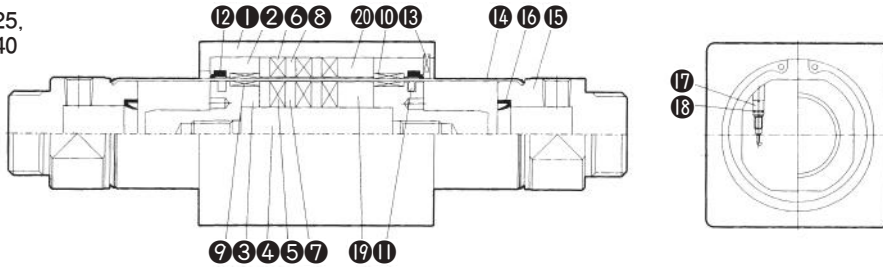

No.	Description	Material	Note
1	Slider	Aluminum alloy	Hard Alumite
2	Holder	Aluminum alloy	White Alwnite
3	Piston	Aluminum alloy	Zink Chromate
4	Shaft	Stainless steel	
5	Inner Magnet	-	Nickel Plated
6	Outer Magnet	-	"
7	Inner Yoke	Carbon steel	Zinc Chromate
8	Outer Yoke	Carbon steel	"
9	Inner Wear Ring	Resin	
10	Outer Wear Ring	Resin	
11	Piston Packing	NBR	
12	Wiper Ring	NBR	

No.	Description	Material	Note
13	Snap Ring	Spring steel	
14	CylinderTube	Stainless steel	
15	End Cover	Aluminum alloy	Hard Alumite
16	Cushion Packing	NBR	
17	Cushion Valve	Carbon steel	
18	Cushion Valve O-Ring	NBR	
19	Inner Spacer	Aluminum alloy	
20	Outer Spacer	Aluminum alloy	

## Guide Type:Construction/Part List

AMRGH  $\phi 10, \phi 16$

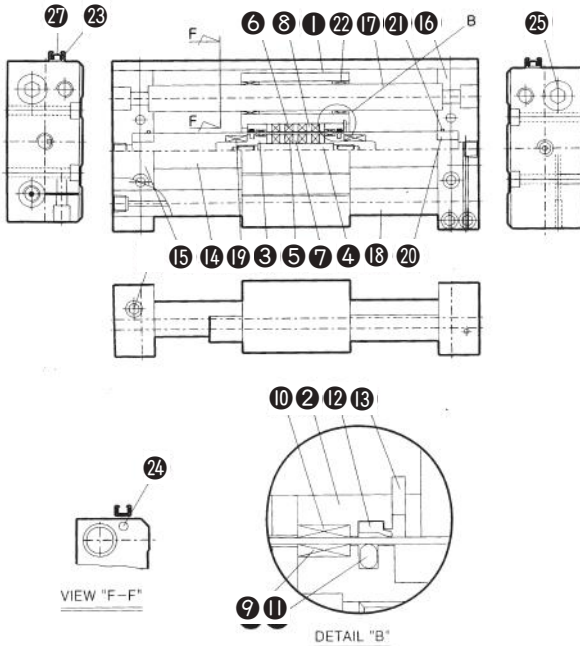

No.	Description	Material	Note
1	Slider	Aluminum alloy	Hard Alumite
2	Holder	Aluminum alloy	White Alumite
3	Piston	Aluminum alloy	Zinc Chromate
4	Shaft	Stainless steel	
5	Inner Magnet	-	Nickel Plated
6	Outer Magnet	-	"
7	Inner Yoke	Carbon Steel	Zomc Chromate
8	Outer Yoke	Carbon Steel	"
9	Inner Wear Ring	Resin	
10	Outer Wear Ring	Resin	
11	Piston Packing	NBR	
12	Wiper Ring	NBR	
13	Snap Ring	Spring Steel	
14	CylinderTube	Stainless steel	
15	End Cover A	Aluminum alloy	Hard Alumite
16	End Cover B	Aluminum alloy	"
17	Guide Rod A	Carbon Steel	Hard Chrome Plated
18	Guide Rod B	Carbon Steel	"
19	Bumper	Urethane	
20	Cushion Stopper	Aluminum alloy	Zinc Chromate
21	Cyl Tube Gasket	NBR	
22	Guide Bush	PBC3	
23	S/W Holder	Aluminum alloy	White Alumite
24	S/W Magnet	-	Nickel Plated
25	Guide Rod Bolt A	Carbon Steel	"
26	Guide Rod Bolt B	Carbon Steel	"
27	S/W Holder Bolt	Carbon Steel	"

# Series AMR

## Construction/Guide Type

AMRGH  $\phi 20, \phi 25, \phi 32, \phi 40$

AMRGL  $\phi 20, \phi 25, \phi 32, \phi 40$

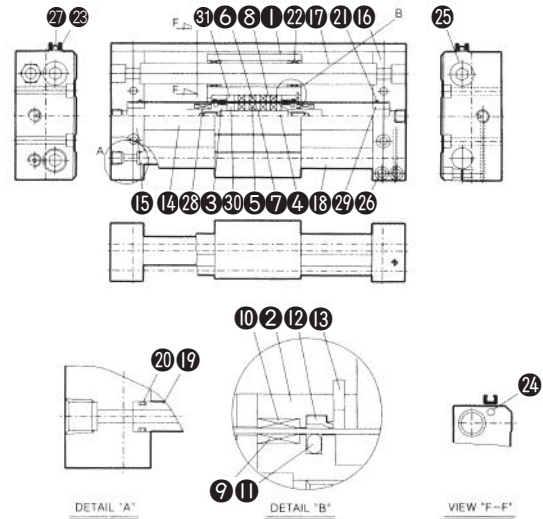
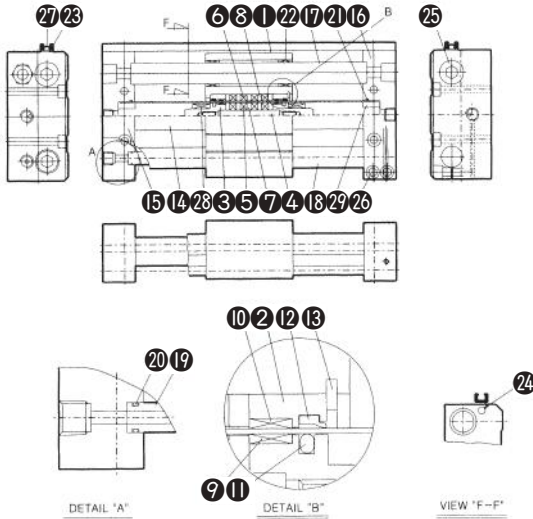

No.	Description	Material	Note
1	Slider	Aluminum alloy	Hard Alumite
2	Holder	Aluminum alloy	"
3	Piston	Aluminum alloy	Zinc Chromate
4	Shaft	Stainless steel	
5	Inner Magnet	-	Nickel Plated
6	Outer Magnet	-	"
7	Inner Yoke	Carbon Steel	Zinc Chromate
8	Outer Yoke	Carbon Steel	"
9	Inner Wear Ring	Resin	
10	Outer Wear Ring	Resin	
11	Piston Packing	NBR	
12	Wiper Ring	NBR	
13	Snap Ring	Spring steel	
14	Cylinder Tube	Stainless steel	
15	End Cover A	Aluminum alloy	White Alumite
16	End Cover B	Aluminum alloy	"
17	Guide Rod A	Carbon Steel	Hard Chrome Plated
18	Guide Rod B	Carbon Steel	"
19	Air Pipe	Carbon Steel	
20	Air Pipe O-Ring	NBR	
21	Cyl. Tube O-Ring	NBR	
22	Guide Bush	PBC3	
23	S/W Holder	Aluminum alloy	White Alumite
24	S/W Magnet	-	Nickel Plated
25	Guide Rod Bolt A	Carbon Steel	"
26	Guide Rod Bolt B	Carbon Steel	"
27	S/W Holder Bolt	Carbon Steel	"
28	Bumper	Urethane	
29	Cushion Stopper	Aluminum alloy	Zinc Chromate

No.	Description	Material	Note
1	Slider	Aluminum alloy	Hard Alumite
2	Holder	Aluminum alloy	"
3	Piston	Aluminum alloy	Zinc Chromate
4	Shaft	Stainless steel	
5	Inner Magnet	-	Nickel Plated
6	Outer Magnet	-	"
7	Inner Yoke	Carbon Steel	Zinc chromate
8	Outer Yoke	Carbon Steel	"
9	Inner Wear Ring	Resin	
10	Outer Wear Ring	Resin	
11	Piston Packing	NBR	
12	Wiper Ring	NBR	
13	Snap Ring	Spring Steel	
14	Cylinder Tube	Stainless steel	
15	End Cover A	Aluminum alloy	White Alumite
16	End Cover B	Aluminum alloy	"
17	Guide Rod A	Carbon Steel	Hard Chrome Plated
18	Guide Rod B	Carbon Steel	"
19	Air Pipe	Carbon Steel	
20	Air Pipe O-Ring	NBR	
21	Cyl. Tube Gasket	NBR	
22	Guide Bush	PBC3	
23	S/W Holder	Aluminum alloy	White Alumite
24	S/W Magnet	-	Nickel Plated
25	Guide Rod Bolt A	Carbon Steel	"
26	Guide Rod Bolt B	Carbon Steel	"
27	S/W Holder Bolt	Carbon Steel	"
28	Bumper	Urethane	
29	Cushion Stopper	Aluminum alloy	zinc Chromate
30	Inner Spacer	Aluminum alloy	White Alumite
31	Outer Spacer	Aluminum alloy	"

- ACP
- APM
- AS
- AX
- AM2
- AM
- AL
- ALX
- AQ
- ADQ
- AQ2
- ADQ2
- AJ
- AJM
- ABK
- ACK1
- NSK
- AG
- NGQ
- AGX
- GX
- NP
- ADR
- AMR**
- NDM
- ARD
- NST
- AST
- ASTH
- NLCD
- NLCS



# Series AMR

## Dimensions / Basic Type

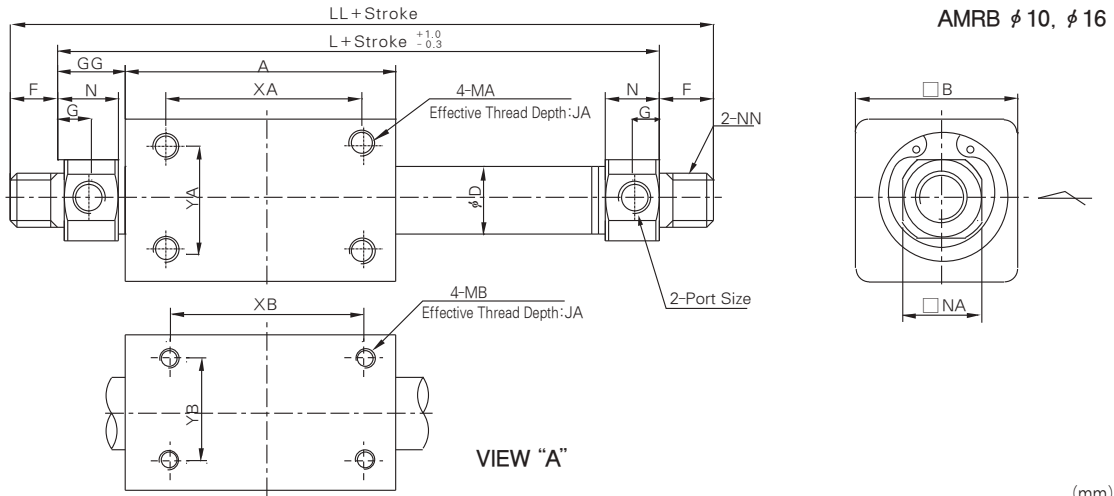

Model	Stroke Range	Port Size	A	B	φD	F	G	GG	JA	JB	L	LL	MA	MB	N	NA	NN	XA	YA	XB	YB
AMRB*10	~300	M5×0.8	42	25	11	8	4.5	10.5	4.5	4.5	63	79	M4×0.7	M3×0.5	9	12	M8×1.0	30	16	30	16
AMRB*16	~300	M5×0.8	55	35	17.4	8	4.5	14	5.5	5.5	83	99	M5×0.8	M4×0.7	9	18	M10×1.0	35	20	35	19

Model	Stroke range	Port size	A	B	φD	F	G	GG	JA	JB	L	LL	MA	MB	N	NA	NN	XA	YA	XB	YB
UAMRBH10	12inch	No.10-32UNF	1.65	0.98	0.43	0.31	0.18	0.41	0.18	0.18	2.48	3.11	8-32UNC	5-40UNC	0.35	0.47	5/16-24UNF	1.18	0.63	1.18	0.63
UAMRBH16	12inch	No.10-32UNF	2.17	1.38	0.69	0.31	0.18	0.55	0.22	0.22	3.27	3.90	10-32UNF	8-32UNC	0.35	0.71	3/8-24UNF	1.38	0.79	1.38	0.75

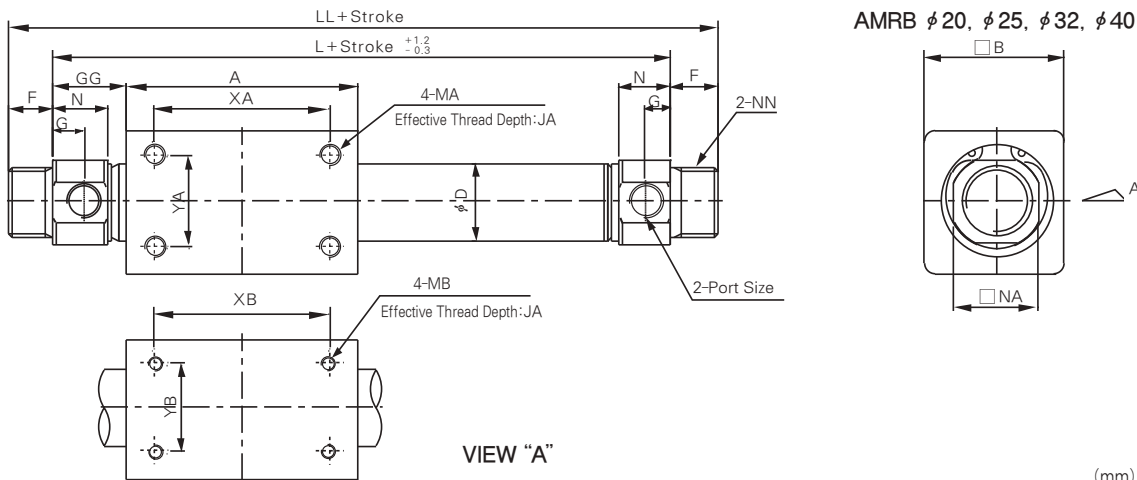

Model	Stroke Range	Port Size	A	B	φD	F	G	GG	JA	JB	L	LL	MA	MB	N	NA	NN	XA	YA	XB	YB
AMRB*20	~1,500	Rc 1/8	66	40	21.6	13	8	20	9	9	106	132	M6×1.0	M4×0.7	14.8	24	M20×1.5	50	26	50	25
AMRB*25	~1,500	Rc 1/8	75	50	26.6	13	8	18	9	9	111	137	M6×1.0	M5×0.8	14.8	30	M26×1.5	50	35	50	30
AMRB*32	~1,500	Rc 1/8	88	60	33.8	13	8	18	12	12	124	150	M8×1.25	M6×1.0	14.8	34.5	M26×1.5	60	40	50	40
AMRB*40	~1,500	Rc 1/4	91	70	42	16	11	29.5	11	11	150	182	M8×1.25	M6×1.0	21.3	42.5	M32×2.0	60	45	60	40

Model	Stroke range	Port size	A	B	φD	F	G	GG	JA	JB	L	LL	MA	MB	N	NA	NN	XA	YA	XB	YB
UAMRB□20	0.5~60inch	NPT 1/8	2.60	1.57	0.85	0.51	0.31	0.64	0.35	0.35	4.17	5.20	1/4-28UNF	8-32UNC	0.58	0.94	3/4-16UNF	1.97	1.02	1.97	0.98
UAMRB□25	0.5~60inch	NPT 1/8	2.95	1.97	1.05	0.51	0.31	0.60	0.35	0.35	4.37	5.40	1/4-28UNF	10-32UNF	0.58	1.18	1-12UNF	1.97	1.38	1.97	1.18
UAMRB□32	0.5~60inch	NPT 1/8	3.46	2.36	1.33	0.51	0.31	0.61	0.47	0.47	4.88	5.90	5/16-24UNF	1/4-28UNF	0.58	1.36	1-12UNF	2.36	1.57	1.97	1.57
UAMRB□40	0.5~60inch	NPT 1/4	3.58	2.76	1.65	0.63	0.43	1.06	0.43	0.43	5.90	7.17	5/16-24UNF	1/4-28UNF	0.84	1.67	1 1/4-12UNF	2.36	1.77	2.36	1.57

# AMR series

## Basic type

AMRB Ø50

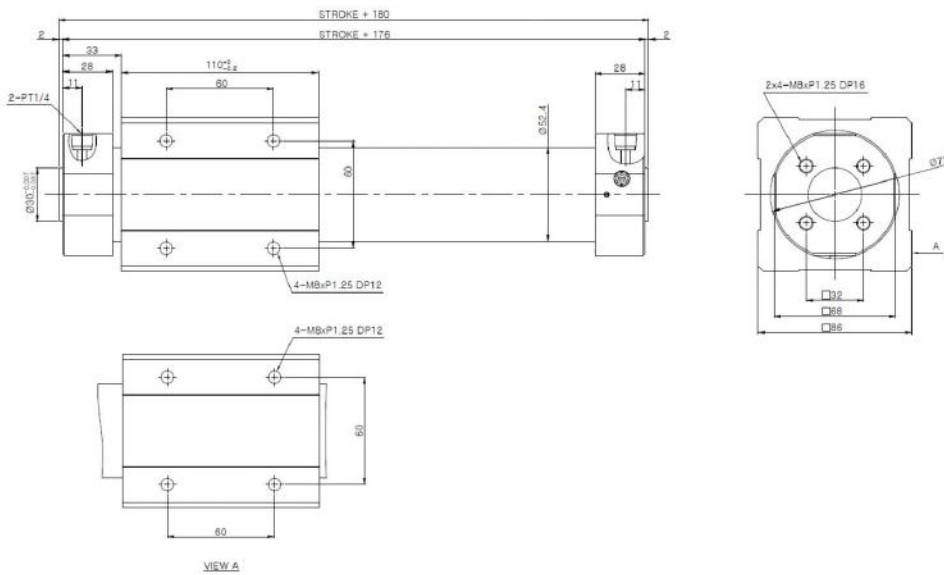

## Foot type

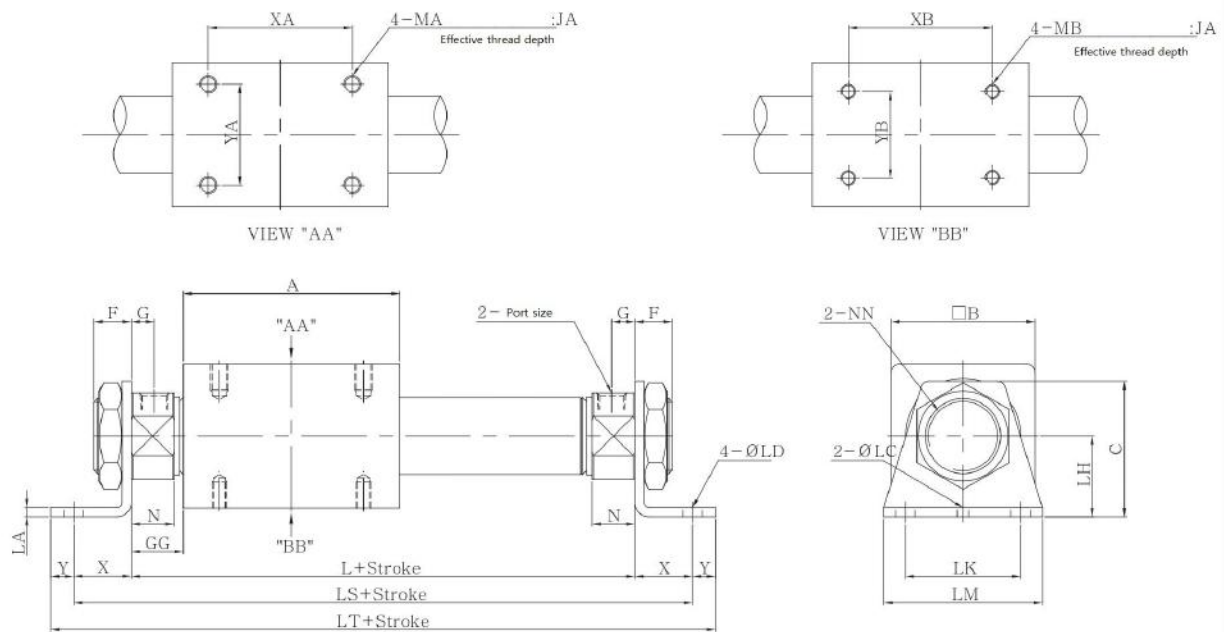

Type	Stroke	Port size	A	B	C	F	G	GG	JA	L	LS	LT	MA	MB	N	NN	XA	YA	XB	YB	X	Y	LH	LK	LM	LA	LC	LD
★AMRL*10	-300	M5×0.8	42	25	16.5	8	4.5	10.5	4.5	63	77	87	M4×0.7	M3×0.5	9	M8×1.0	30	16	30	16	7	5	9	24	32	1.6	-	4.5
★AMRL*16	-300	M5×0.8	55	35	25	8	4.5	14	5.5	83	101	113	M5×0.8	M4×0.7	9	M10×1.0	35	20	35	19	9	6	14	33	42	2.3	-	5.5
AMRL*20	-1500	RcPT1/8	66	40	40	13	8	20	9	106	146	162	M6×1.0	M4×0.7	14.8	M20×1.5	50	26	50	25	20	8	25	40	55	3.2	4	6.8
AMRL*25	-1500	RcPT1/8	75	50	47	13	8	18	9	111	151	167	M6×1.0	M5×0.8	14.8	M26×1.5	50	35	50	30	20	8	28	40	55	3.2	4	6.8
★AMRL*32	-1500	RcPT1/8	88	60	47	13	8	18	12	124	164	180	M8×1.25	M6×1.0	14.8	M26×1.5	60	40	50	40	20	8	28	40	55	3.2	4	6.8
★AMRL*40	-1500	RcPT1/4	91	70	54	16	11	29.5	11	150	198	216	M8×1.25	M6×1.0	21.3	M32×2.0	60	45	60	40	23	10	30	55	75	3.2	4	7



# Series AMR

## Guide/ Slider Bearing Type

AMRG  $\phi 10, \phi 16$

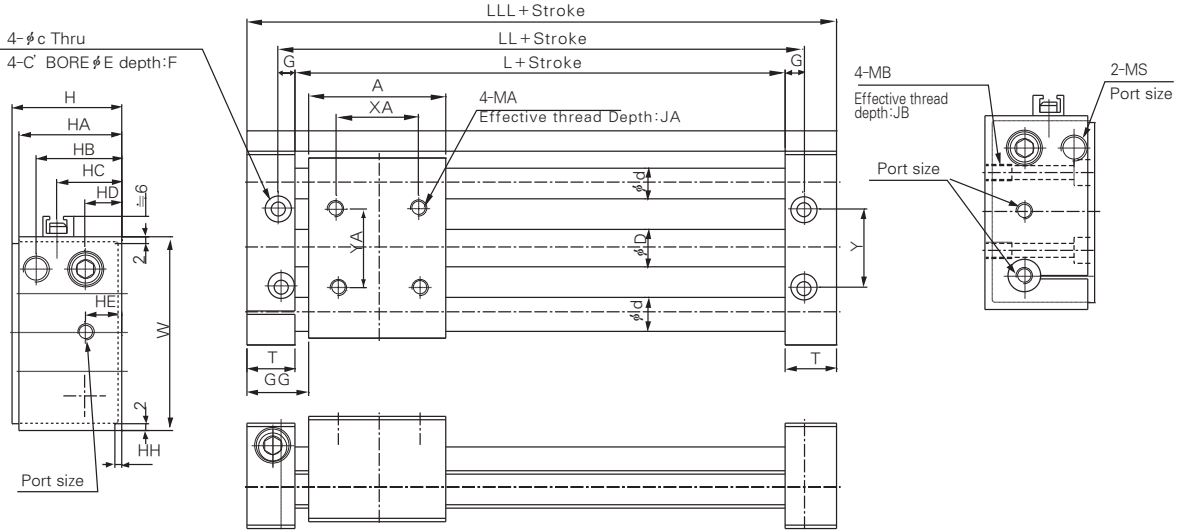

- ACP
- APM
- AS
- AX
- AM2
- AM
- AL
- ALX
- AQ
- ADQ
- AQ2
- ADQ2
- AJ
- AJM
- ABK
- ACK1
- NSK
- AG
- NGQ
- AGX
- GX
- NP
- ADR
- AMR**
- NDM
- ARD
- NST
- AST
- ASTH
- NLCD
- NLCS

(mm)

Model	Stroke Range	Port Size	A	$\phi C$	$\phi D$	$\phi d$	$\phi E$	F	GG	G	H	HA	HB	HC	HD	HE	HH	JA	JB	L	LL	LLL	MA	MB	MS	T	W	XA	Y	YA
AMRG $\phi 10$	~500	M5 $\times$ 0.8	42	4.3	11	10	8	5	19	5	34	32	27	20	12	12	2	10	8	50	60	80	M5 $\times$ 0.8	M5 $\times$ 0.8	M8 $\times$ 1.0	15	60	25	24	25
AMRG $\phi 16$	~700	M5 $\times$ 0.8	55	5.2	17.4	10	10	7	23	7	40	38	30	24	15	15	2	12	10	61	75	101	M5 $\times$ 0.8	M8 $\times$ 1.0	M8 $\times$ 1.0	20	75	30	30	30

(inch)

Model	Stroke range	Port size	A	$\phi C$	$\phi D$	$\phi d$	$\phi E$	F	GG	G	H	HA	HB	HC	HD	HE	HH	JA	JB	L	LL	LLL	MA	MB	MS	T	W	XA	Y	YA
UAMRGH10	0.5~20inch	10-32UNF	1.65	0.17	0.43	0.39	0.31	0.20	0.74	0.20	1.34	1.26	1.06	0.79	0.47	0.39	0.31	1.97	2.36	3.15	10-32UNF	10-32UNF	5/16-24UNF	0.59	2.36	0.98	0.94	0.98		
UAMRGH16	0.5~20inch	10-32UNF	2.17	0.20	0.69	0.39	0.39	0.28	0.90	0.28	1.57	1.50	1.18	0.94	0.51	0.47	0.39	2.40	2.95	3.98	1/4-28UNF	1/4-28UNF	5/16-24UNF	0.79	2.95	1.18	1.18	1.18		

# Series AMR

## Guide/ Slider Bearing Type

AMRG  $\phi 20$ ,  $\phi 25$ ,  $\phi 32$ ,  $\phi 40$

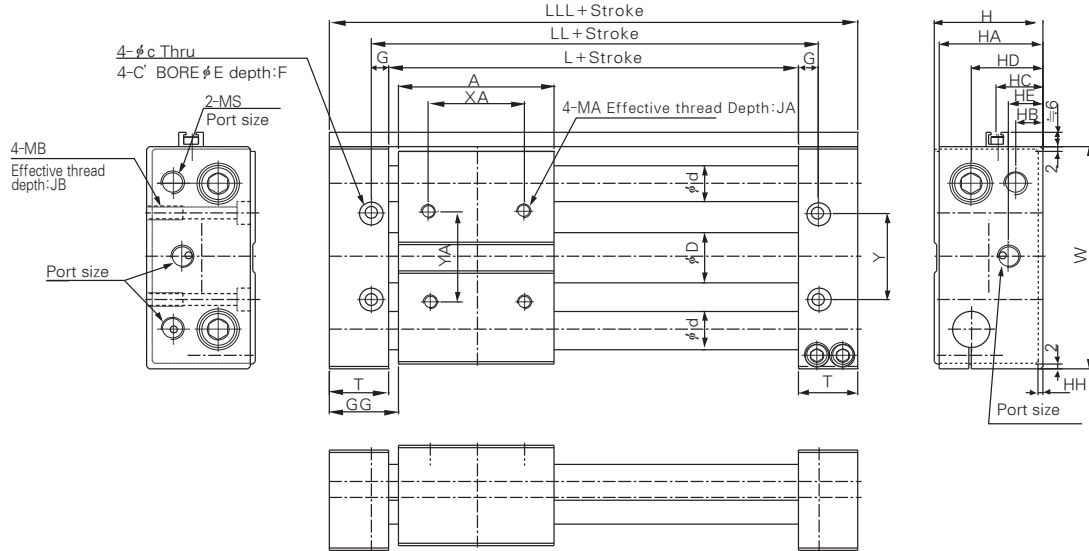

(mm)

Model	Stroke Range	Port Size	A	$\phi C$	$\phi D$	$\phi d$	$\phi E$	F	GG	G	H	HA	HB	HC	HD	HE	HH	JA	JB	L	LL	LLL	MA	MB	MS	T	W	XA	Y	YA
AMRG $\phi 20$	~1,000	Rc 1/8	66	5.2	21.6	16	10	6	29	8	46	44	11	19	30	14.5	2	8	15	74	90	124	M6 $\times$ 1.0	M6 $\times$ 1.0	M10 $\times$ 1.0	25	98	40	38	40
AMRG $\phi 25$	~1,500	Rc 1/8	74	6.8	26.6	16	11	7	25	8	54	52	15	23	34	18.5	2	8	16	74	90	124	M6 $\times$ 1.0	M8 $\times$ 1.25	M14 $\times$ 1.5	25	102	40	42	40
AMRG $\phi 32$	~1,500	Rc 1/8	88	8.6	33.8	20	14	8.6	29	10	64	62	19.5	29.5	42.5	19	4	12	16	90	110	146	M8 $\times$ 1.25	M10 $\times$ 1.5	M20 $\times$ 1.5	28	122	50	50	50
AMRG $\phi 40$	~1,500	Rc 1/4	91	8.6	42	25	14	8.6	34.5	10	74	72	20	34.5	47.5	20	4	12	14	100	120	160	M8 $\times$ 1.25	M10 $\times$ 1.5	M20 $\times$ 1.5	30	145	64	64	64

(inch)

Model	Stroke range	Port size	A	$\phi C$	$\phi D$	$\phi d$	$\phi E$	F	GG	G	H	HA	HB	HC	HD	HE	HH	JA	JB	L	LL	LLL	MA	MB	MS	T	W	XA	Y	YA
UAMRG $\square 20$	0.5~40inch	NPT 1/8	2.60	0.20	0.85	0.63	0.39	1.14	0.24	0.31	1.81	1.73	0.43	0.75	0.57	0.31	0.59	2.91	3.54	4.88	1/4-28UNF	1/4-28UNF	3/8-24UNF	0.98	3.86	1.57	1.50	1.57		
UAMRG $\square 25$	0.5~60inch	NPT 1/8	2.91	0.27	1.05	0.63	0.43	0.98	0.28	0.31	2.12	2.05	1.59	0.91	0.73	0.31	0.63	2.91	3.54	4.88	1/4-28UNF	5/16-24UNF	9/16-18UNF	0.98	4.02	1.57	1.65	1.57		
UAMRG $\square 32$	0.5~60inch	NPT 1/8	3.46	0.34	1.33	0.79	0.55	1.14	0.34	0.39	2.52	2.44	0.77	1.16	0.75	0.47	0.63	3.54	4.33	5.75	5/16-24UNF	3/8-24UNF	3/4-16UNF	1.10	4.80	1.97	1.97	1.97		
UAMRG $\square 40$	0.5~60inch	NPT 1/4	3.58	0.34	1.65	0.98	0.55	1.36	0.34	0.39	2.91	2.83	0.79	1.36	0.79	0.47	0.55	3.94	4.72	6.30	5/16-24UNF	3/8-24UNF	3/4-16UNF	1.18	4.72	2.52	2.52	2.52		

# Series AMR

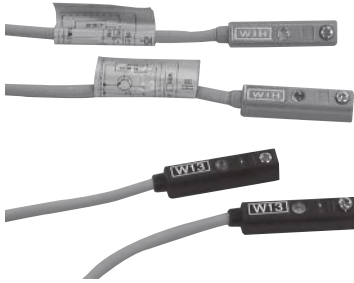

## How to Order

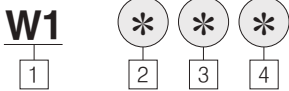

- 1 TPC Auto Switch Model
- 2 3 : Reed AUTO S/W  
H : Solid State AUTO S/W
- 3 N : 3 wire(NPN)  
P : 3 wire(PNP)
- 4 Blank : LEAD WIRE(0.5m)  
M : LEAD WIRE(1m)  
L : LEAD WIRE(3m)

## Internal Circuit

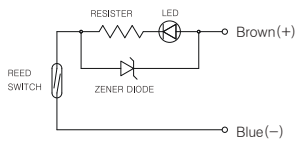

2 wire reed circuit

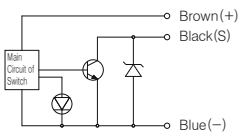

3 wire NPN solid state circuit

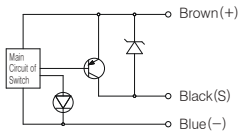

3 wire PNP solid state circuit

### Caution

Please read and understand the instructions before use. Refer to the auto switch precautions before using auto switches.

## Specifications

Part No.	W13	W1HN(P)
Contact wiring	Reed Switch 2 wire	Solid Stage Switch 3 wire
Application	Relay, Sequence Control	
Voltage	DC24V	AC100V DC24V
Current	5~40mA	5~20mA ≤40mA
Contact Protection Circuit	None	Built-in
Internal Voltage Drop	Under 2.4V	≤1.5V
Indicator Lamp	ON : When Red LED	
Output	-	NPN(PNP)
Current Consumption	-	≤5mA
Current Leakage	None	≤100μA
Operation Time	≤1ms	≤2ms
Lead Wire	Oil Resistant Vinyl Code	
Shock Resistance	30G 100G	
Insulation Resistance	100MΩ or more (500DVC Mega) between lead wire and case	
Voltage Resistance	For 1 min. (in AC1500V/between a lead wire case)	
Temperature	-10 ~ 60°C	
Protection Structure	IEC Standard IP67, Water Proof, and (JISC0920), Oil Structure	

## Protection Structure

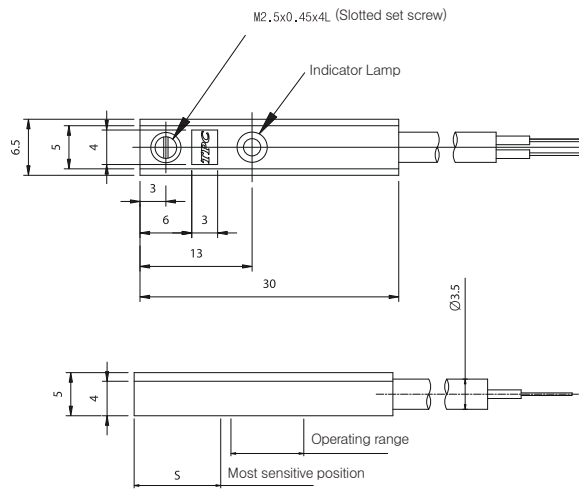

## Operating Range

Section	W13	W1HN(P)
Most sensitive position(S)	10mm	1 ~ 2mm
Operation range(L)	6 ~ 12mm	4 ~ 10mm

ACP

APM

AS

AX

AM2

AM

AL  
ALX

AQ  
ADQ

AQ2  
ADQ2

AJ  
AJM

ABK

ACK1

NSK

AG

NGQ

AGX  
GX

NP

ADR

**AMR**

NDM

ARD

NST

AST

ASTH

NLCD

NLCS