

Series AL/ALX

Air Cylinder

Bore size(mm) : Ø125, Ø140, Ø160, Ø180, Ø200, Ø250, Ø300

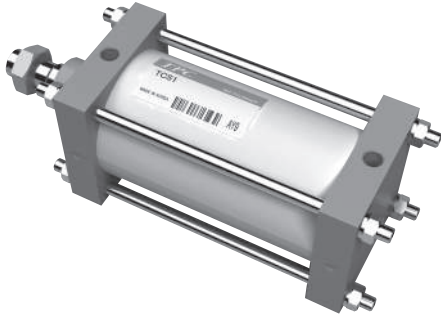

- WIDE BORE AND STROKE RANGE
- LONG LIFE AND HIGH SPEED OPERATION POSSIBLE
- BUILT-IN AIR CUSHION

Symbol

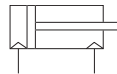

How to Order

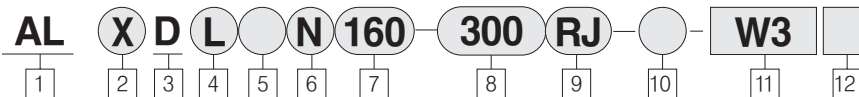

1 Air Cylinder

2 Model Series

Blank : Ø125, Ø140, Ø160, Ø180, Ø200, Ø250, Ø300
 : Nose Separator
 X : (Ø125, Ø140, Ø160 Only)
 : Nose Solid

3 Magnet

Blank : None
 D : Built-in Magnet (ALX125, 140, 160 only)

4 Mounting

B : Basic
 L : Foot
 F : Rod Side Flange
 G : Head Side Flange
 C : Single Rear Clevis
 D : Double Rear Clevis
 T : Center Trunnion

5 Tube Material

Ø125~Ø160
 Blank : Aluminum Tube
 F : Iron Tube
 Ø180~Ø300
 Blank : Iron Tube (Standard)
 * Iron Tube: Not available Auto Switch

6 Type

Blank : Lubricated
 N : Non-Lube
 H : Air-Hydro (Except Series ALX)

7 Bore Size

125 : 125mm
 140 : 140mm
 160 : 160mm
 180 : 180mm
 200 : 200mm
 250 : 250mm
 300 : 300mm
 * AL : 125~300 (Standard Type)
 * ALX : 125, 140, 160 (Upgrade Type)

* ALX Air-hydro type is available up to bore size Ø160
 * Air-hydro type is AL series type
 * Applicable bore size Ø125 to 160 is standard type for ALX

8 Stroke (mm)

125 : ~1,000
 140 : ~1,000
 160 : ~1,200
 180~300 : ~2,000
 * Consult TPC for other stroke

9 Suffix Symbol for Cylinder

Blank : Without Gaiter
 /Both End Air Cushion
 J : Nylon Tarpoulin
 K : Neoprene Cloth
 R : Rod end Air Cushion
 H : Head end Air Cushion
 N : Non-Cushion

10 Series

Blank : Standard Type
 XC16 : Copper-Free

11 Auto switch

Blank : None
 W3 : Reed Switch Type (AC110V, 220V, DC24V)

Standard auto switch lead wire length is 0.5m

12 Number of Auto Switches

Blank : 2 pcs
 S : 1 pc
 N : N pcs

Series AL/ALX

Specification		
Type	Lube, Non-Lube	Air-Hydro
Fluid	Air L.P.Oil	
Proof Pressure	1.6MPa(227psi)	
Max.Operating Pressure	1.0MPa(140psi)	
Min.Operating Pressure	0.05MPa(7psi)	0.06MPa(8psi)
Ambient and Fluid Temperature	5~60°C (41~140°F)	
Piston Speed	50~500mm/s	0.5~200mm/s
Cushion	With Cushion	Non Cushion
Stroke Tolerance (mm)	~250 st ₀ ^{+1.0} , 251~1000 st ₀ ^{+1.4} , 1001~1500 st ₀ ^{+1.8}	
Mounting	Basic, Foot, Front flange, Rear flange, Single clevis, Double clevis, Center trunnion	

Parts No. of Mounting Bracket							
Bore size	φ 125	φ 140	φ 160	φ 180	φ 200	φ 250	φ 300
Foot	TCS1L125	TCS1L140	TCS1L160	TCS1L180	TCS1L200	TCS1L250	TCS1L300
Flange	TCS1F125	TCS1F140	TCS1F160	TCS1F180	TCS1F200	TCS1F250	TCS1F300
Single Clevis	TCS1C125	TCS1C140	TCS1C160	TCS1C180	TCS1C200	TCS1C250	TCS1C300
Double Clevis	TCS1D125	TCS1D140	TCS1D160	TCS1D180	TCS1D200	TCS1D250	TCS1D300

Model				
Model	Type	Action	Seal	Bore size(mm)
AL	Lubricated	Double	O-ring	125, 140, 160, 180
ALN	Non-lube type	Double	Special	200, 250, 300
ALH	Air-hydro type	Double	Special	125, 140, 160

※ Series ALX : φ 125, φ 140, φ 160

Weight/Aluminum Tube : Lubricated(Non-Lube, Air-Hydro)				(kgf/lbf)
Bore Size (mm)		125	140	160
Standard Weight	Basic Type	14.85 (13.73)	17.98 (16.57)	24.78 (23.04)
	Foot Type	16.49 (15.37)	20.50 (19.09)	27.57 (25.83)
	Rod-Side Flange Type	17.53 (16.41)	22.99 (21.58)	31.16 (29.42)
	Head-Side Flange Type	17.54 (16.42)	22.98 (21.57)	31.16 (29.42)
	Single Rear Clevis Type	17.92 (16.80)	22.27 (20.86)	30.26 (28.52)
	Double Rear Clevis Type(With pin)	18.39 (17.26)	23.03 (21.62)	31.11 (29.37)
	Trunnion Type	18.98 (17.86)	23.71 (22.30)	32.17 (30.43)
Extra Weight per 100 Strokes		1.77	1.96	2.39
Accessory Fittings	Single Knuckle	0.91	1.16	1.56
	Double Knuckle(With pin)	1.37	1.81	2.48

※ () : In parenthesis are for Non-Lubetype, Air-Hydro Type
 Calculation Example : ALXL 160-500
 • Basic Weight ...60.78lbf (Foot type, φ 160)
 • Additional Weight ...5.27/100 Stroke
 • Cylinder Stroke...500stroke
 60.78+5.27×500/100=87.13lbf

- ACP
- APM
- AS
- AX
- AM2
- AM
- AL
ALX
- AQ
ADQ
- AQ2
ADQ2
- AJ
AJM
- ABK
- ACK1
- NSK
- AG
- NGQ
- AGX
GX
- NP
- ADR
- AMR
- NDM
- ARD
- NST
- AST
- ASTH
- NLCD
- NLCS

Series AL/ALX

Weight/Iron Tube (kgf)								
Bore size(mm)		125	140	160	180	200	250	300
Standard Weight	Basic Type	15.20	18.38	25.24	34.16	42.66	79.78	115.94
	Foot Type	16.83	20.90	28.04	38.36	47.54	89.28	133.22
	Rod-side Flange Type	17.88	23.38	31.64	43.99	54.58	101.62	146.14
	Head-side Flange Type	17.88	23.38	31.64	43.99	54.58	101.62	146.14
	Single Rear Clevis Type	18.28	22.68	30.73	42.55	52.56	98.17	149.22
	Double rear Clevis Type(With pin)	18.73	23.42	31.58	44.23	54.59	101.37	154.96
	Trunnion Type	19.33	24.11	32.64	44.78	56.65	107.63	156.37
Extra Weight per 100 Stroke		2.66	3.02	3.58	4.95	5.75	9.08	12.15
Accessory Fittings	Single Knuckle	0.91	1.16	1.56	3.07	2.90	5.38	10.82
	Double Knuckle(With pin)	1.37	1.81	2.48	4.74	4.59	9.22	17.17

Rod boot Material		
Symbol	Material	Max. ambient temperature
J	Nylon tarpaulin	60°C (140°F)
K	Neoprene cloth	※110°C (230°F)

※ Max. ambient temperature for the rod boot itself

Accessories								
Description		Mounting						
		Basic	Foot	Front Flange	Rear Flange	Single Clevis	Double Clevis	Center Trunnion
Standard	Clevis pin	—	—	—	—	—	○	—
	Rod Front Nut	○	○	○	○	○	○	○
Option	Single Knuckle joint	○	○	○	○	○	○	○
	Double knuckle joint(with pin)	○	○	○	○	○	○	○
	Gaiter	○	○	○	○	○	○	○

- ### Cautions
- (1) When connecting piping, securely flush the piping to eliminate dust and chips from the cylinder
 - (2) During operation, load should be applied constantly to the piston rod in the axial direction.
 - (3) Don't scratch and hit the sliding section of the piston rod. The damage causes packing damage and can induce leakage.
 - (4) Use turbine oil No. 1 (ISO VG32) for lubrication. Avoid machine oil and spindle oil.

Second Class Pressure Vessel	
If the stroke is over below numbers, it becomes second class pressure vessel.	
Bore Size (mm)	Stroke (mm)
160	1,986
180	1,569
200	998
250	813
300	564

Series AL/ALX

Construction/Parts List (AL)

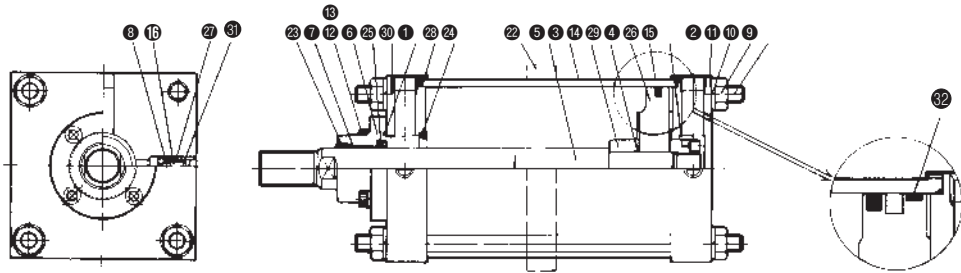

For Aluminum Tube

Main Parts

No.	Description	Material	Note
1	Rod Cover	#Rolled Steel	≒Black paint
2	Head Cover	#Rolled Steel	≒Black paint
3	Cylinder Tube	$\phi 125 \sim \phi 160$	Aluminum Alloy Hard alumite
		$\phi 140 \sim \phi 300$	Carbon Steel Hard chrome plated
4	Piston	$\phi 125 \sim \phi 160$	Aluminum Alloy
		$\phi 180 \sim$	Cast Iron
5	Piston Rod	Carbon Steel	Hard chrome plated
6	Nose	Cast Iron	Black Paint
7	Bush	Lead Bronze Casting	
8	Valve Guide	Brass	
9	Tie Rod	Carbon Steel	Uni-chromate
10	Tie Rod Nut	Rolled Steel	Black zinc chromate
11	Spring Washer	Steel Wire	Black zinc chromate
12	Nose Cap Screw	Chrome-Molybdenum Steel	Black zinc chromate
13	Spring Washer	Steel Wire	Black zinc chromate
14	Cushion Piece A	Rolled Steel	Kani-zen plated
15	Cushion Piece B	Rolled Steel	Kani-zen plated
16	Cushion Needle	Rolled Steel	Kani-zen plated
17	* Space A	Rolled Steel	Zinc chromate
18	* Space B	Rolled Steel	Zinc chromate
19	* Air Exhaust Valve A	Rolled Steel	Zinc chromate
20	* Air Exhaust Valve B	Chrome-molybdenum Steel	
21	* Check Ball	Chrome Bearing Steel	
22	Tie rod Reinforcing Ring	Rolled Steel	Black paint
32	Wear Ring	Resin	

For AL series : Aluminum alloy
 ≒ For AL series : Silver paint
 * For Air-hydro type
 ★ Available only for long stroke

Seals

No.	Description	Material	Part No.					
			125	140	160	180	200	250

Lube Type

No.	Description	Material	Part No.							
			125	140	160	180	200	250	300	
23	Wiper Ring	NBR	SDR-36	SDR-36	SDR-36	SDR-36	SDR-36	SDR-36	SDR-36	SDR-36
24	Cushion Seal		DSM-60	DSM-60	DSM-60	DSM-60	SMS-36	DSM-75	PCS-85	
			PCS-75-PL	PCS-75-PL	PCS-75-PL	PCS-75-PL	PCS-75-PL	PCS-75-PL	PCS-75-PL	
25	Rod Seal		PNY-36	PNY-36	PNY-40	PNY-45	PNY-50	PNY-60	PNY-70	
26	Piston Seal		P-115	P-130	P-150	P-165	P-185	P-235	P-238	
27	Cushion Valve Seal		P7	P7	P7	P7	P7	P7	P7	
28	Tube Gasket		C120	C130	C155	C175	C195	CS100-100-94	CS100-100	
29	Piston Gasket		G25	G25	G25	G35	G35	G45	G45	
30	Nose Gasket		G55	G55	G55	G65	G65	G80	G90	
31	Guide Gasket		CA50-1607							

Non-Lube Type

Same as lube type except 23 and 24

No.	Description	Material	Part No.						
			125	140	160	180	200	250	300
25	Rod Seal	NBR	PNY-36	PNY-36	PNY-40	PNY-45	PNY-50	PNY-60	PNY-70
26	Piston Seal		TPSA-125	TPSA-140	TPSA-160	TPSA-180	TPSA-200	TPSA-250	TPSA-300

Air-Hydro Type

Same as lube type except 23 and 24

No.	Description	Material	Parts. No.		
			125	140	160
25	Rod Seal	NBR	SKY-36	SKY-36	SKY-40
26	Piston Seal		RPS-125	RPS-140	RPS-160

ACP

APM

AS

AX

AM2

AM

AL
ALX

AQ
ADQ

AQ2
ADQ2

AJ
AJM

ABK

ACK1

NSK

AG

NGQ

AGX
GX

NP

ADR

AMR

NDM

ARD

NST

AST

ASTH

NLCD

NLCS

Series AL/ALX

Basic Type/(ALB)

Lube Type(ALB), Non-Lube Type(ALBN), Air-Hydro Type(ALBH)

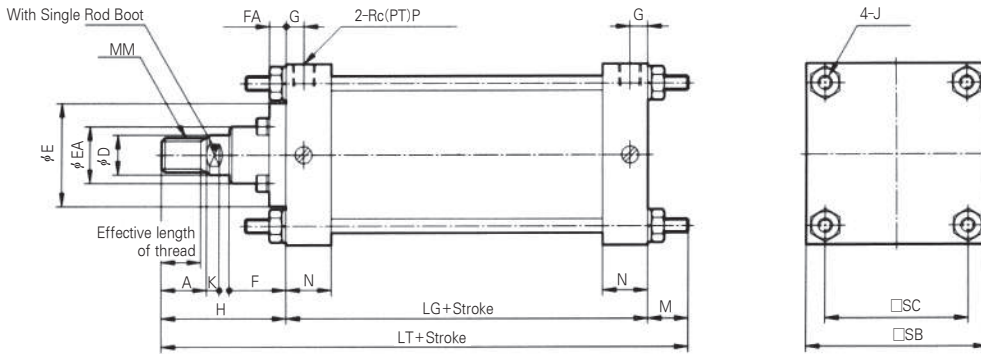

With Single Rod Boot

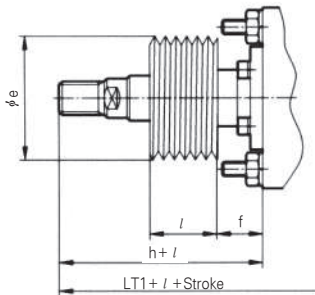

(mm)

Type	Bore size (mm)	*Stroke range (mm)	Effective length thread	A	□SB	□SC	φD	φE	φEA	F	FA	G	J	K	M	MM	N	P	LG
Lube	125	~1,000	47	50	145	115	36	90	59	43	14	16	M14×1.5	15	27	M30×1.5	35	1/2	98
Non-Lube	140	~1,000	47	50	161	128	36	90	59	43	14	16	M14×1.5	15	27	M30×1.5	35	1/2	98
Air-Hydro	160	~1,200	53	56	182	144	40	90	59	43	14	18.5	M16×1.5	17	30.5	M36×1.5	39	3/4	106
Lube	180	~1,200	60	63	204	162	45	115	70	48	17	18.5	M18×1.5	20	35	M40×1.5	39	3/4	111
Non-Lube	200	~1,200	60	63	226	182	50	115	74	48	17	18.5	M20×1.5	20	35	M45×1.5	39	3/4	111
	250	~1,200	67	71	277	225	60	140	86	60	20	23	M24×1.5	25	41.5	M56×2	49	1	141
	300	~1,200	76	80	330	270	70	140	96	60	20	23	M30×1.5	30	51.5	M64×2	49	1	146

Type	Bore size (mm)	Without Rod Boot		With Rod Boot					With Across Flat
		H	LT	φe	f	h	ℓ	LT ₁	
Lube	125	110	235	★75	40	133	0.2Stroke	258	31
Non-Lube	140	110	235	★75	40	133		258	31
Air-Hydro	160	120	256.5	★75	40	141		277.5	36
Lube	180	135	281	85	45	153	0.2Stroke	299	41
Non-lube	200	135	281	90	45	153		299	46
	250	160	342.5	105	55	176	0.17Stroke	358.5	56
	300	175	372.5	115	55	190		387.5	65

* Minimum stroke with Rod Boot: 30mm or more
 ★ Rod Boot material: neoprene cloth - 80mm or more

Series AL/ALX

Foot Type/(ALL)

Lube Type(ALL), Non-Lube Type(ALLN), Air-Hydro Type(ALLH)

φ 125~ φ 200

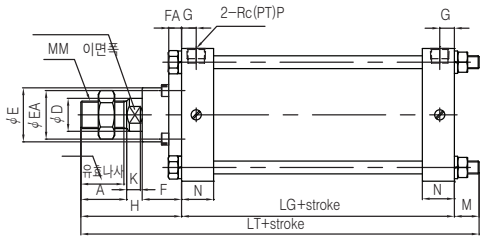

φ 250~ φ 300

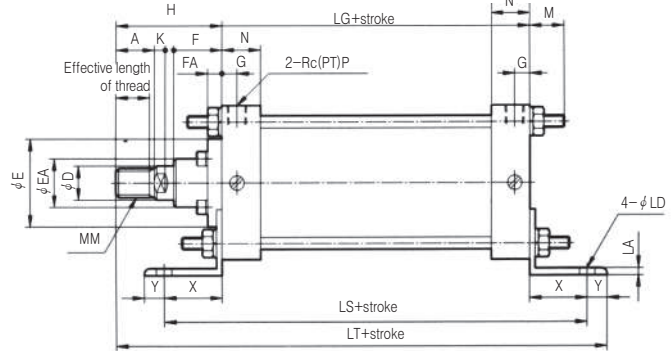

With Single Rod Boot (φ 125~ φ 200)

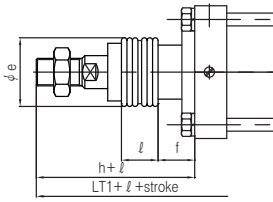

With Single Rod Boot (φ 250~ φ 300)

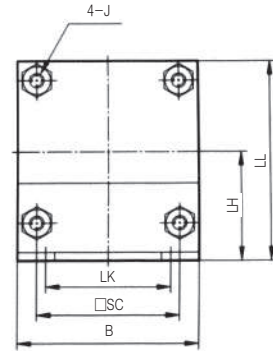
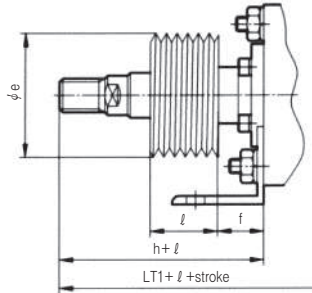

Type	Bore size (mm)	*Stroke range (mm)	Effective length thread	A	B	□SC	φ D	φ E	φ EA	F	FA	G	J	K	MM	N	P	LG	(mm)									
																			X	Y	φ LD	LH	LS	LA	LK	LL	Without Rod Boot	
																			H	LT	φ e	f	h	ℓ	LT1			
Lube	125	~1,400	47	50	145	115	36	90	59	43	14	16	M14×1.5	15	M30×1.5	35	1/2	98										
Non-Lube	140	~1,400	47	50	161	128	36	90	59	43	14	16	M14×1.5	15	M30×1.5	35	1/2	98										
Air-Hydro	160	~1,400	53	56	182	144	40	90	59	43	14	18.5	M16×1.5	17	M36×1.5	39	3/4	106										
Lube	180	~1,800	60	63	204	162	45	115	70	48	17	18.5	M18×1.5	20	M40×1.5	39	3/4	111										
Non-Lube	200	~1,800	60	63	226	182	50	115	74	48	17	18.5	M20×1.5	20	M45×1.5	39	3/4	111										
	250	~2,000	67	71	277	225	60	140	86	60	20	23	M24×1.5	25	M56×2	49	1	141										
	300	~2,000	76	80	330	270	70	140	96	60	20	23	M30×1.5	30	M64×2	49	1	146										
Type	Bore size (mm)	X	Y	φ LD	LH	LS	LA	LK	LL	Without Rod Boot		With Rod Boot																
Lube	125	45	20	19	85	188	8	100	157.5	110	273	★75	40	133											296			
Non-Lube	140	45	30	19	100	188	9	112	180.5	110	283	★75	40	133			0.2Stroke								306			
Air-Hydro	160	50	25	19	106	206	9	118	197	120	301	★75	40	141											322			
Lube	180	60	30	24	125	231	10	132	227	135	336	85	45	153			0.2Stroke								354			
Non-Lube	200	60	30	24	132	231	10	150	245	135	336	90	45	153											354			
	250	80	40	29	160	301	12	180	298.5	160	421	105	55	176			0.17Stroke								437			
	300	90	40	33	200	326	15	212	365	175	451	115	55	190											466			

※ Minimum with Rod Boot:30mm or more

★ Rod Boot material:neoprene cloth-80mm

ACP

APM

AS

AX

AM2

AM

AL
ALX

AQ
ADQ

AQ2
ADQ2

AJ
AJM

ABK

ACK1

NSK

AG

NGQ

AGX
GX

NP

ADR

AMR

NDM

ARD

NST

AST

ASTH

NLCD

NLCS

Series AL/ALX

Long Stroke: Front Flange Type(ALL)

Lube(ALF), NON-Lube(ALFN) Air-Hydro(ALFH)

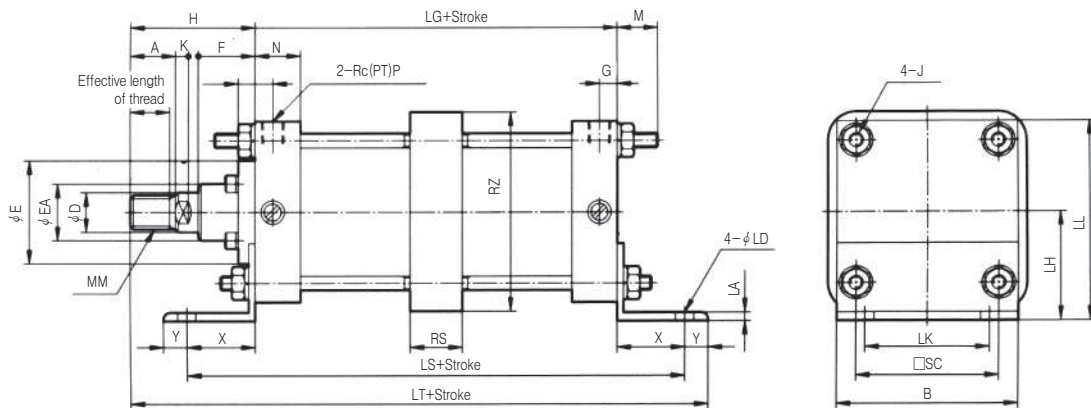

With Single Rod Boot

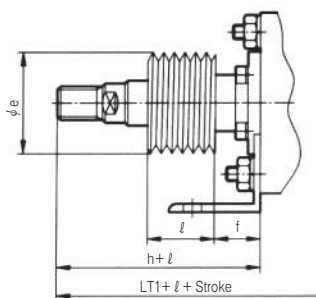

(mm)

Type	Bore size (mm)	Stroke range	Effective length thread	A	B	□SC	φD	φE	φEA	F	FA	G	J	K	MM	N	P	LG
Lube	125	1,401~1,600	47	50	145	115	36	90	59	43	14	16	M14×1.5	15	M30×1.5	35	1/2	98
Non-Lube	140	1,401~1,600	47	50	161	128	36	90	59	43	14	16	M14×1.5	15	M30×1.5	35	1/2	98
Air-Hydro	160	1,401~1,600	53	56	182	144	40	90	59	43	14	18.5	M16×1.5	17	M36×1.5	39	3/4	106
Lube	180	1,801~2,000	60	63	204	162	45	115	70	48	17	18.5	M18×1.5	20	M40×1.5	39	3/4	111
Lube	200	1,801~2,000	60	63	226	182	50	115	74	48	17	18.5	M20×1.5	20	M45×1.5	39	3/4	111
Non-Lube	250	2,001~2,400	67	71	277	225	60	140	86	60	20	23	M24×1.5	25	M56×2	49	1	141
Non-Lube	300	2,001~2,400	76	80	330	270	70	140	96	60	20	23	M30×1.5	30	M64×2	49	1	146

Type	Bore size (mm)	Stroke range	Y	φLD	LH	LS	LA	LK	LL	RS	RZ	Without Rod Boot		With Rod Boot				
												H	LT	φe	f	h	ℓ	LT ₁
Lube	125	45	20	19	85	188	8	100	157.5	50	164	110	273	★75	40	133		296
Non-Lube	140	45	30	19	100	188	9	112	180.5	55	184	110	283	★75	40	133	0.2Stroke	306
Air-Hydro	160	50	25	19	106	206	9	118	197	60	204	120	301	★75	40	141		322
Lube	180	60	30	24	125	231	10	132	227	59	228	135	336	85	45	153	0.2Stroke	354
Lube	200	60	30	24	132	231	10	150	245	59	257	135	336	90	45	153		354
Non-Lube	250	80	40	29	160	301	12	180	298.5	69	325	160	421	105	55	176	0.17Stroke	437
Non-Lube	300	90	40	33	200	326	15	212	365	79	390	175	451	115	55	190		466

★ Rod Boot material: neoprene cloth-80mm

Series AL/ALX

Rod Side Flange Type(ALF)

Lube Type(ALF), Non-Lube Type(ALFN), Air-Hydro Type(ALFH)

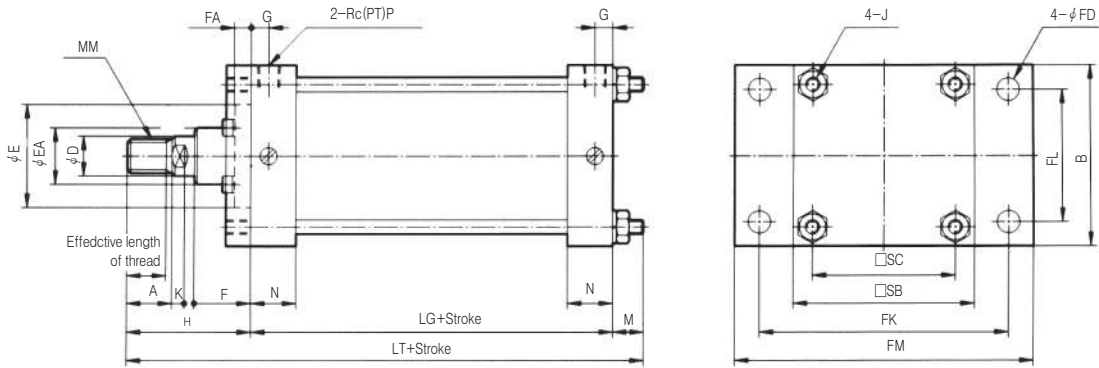

With Single Rod Boot

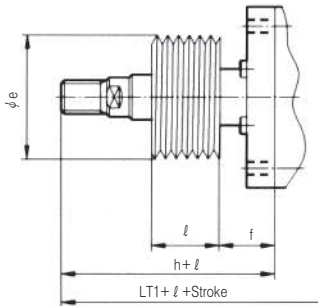

(mm)

Type	Bore size (mm)	※Stroke range	Effective length thread	A	B	□SB	□SC	φD	φE	φEA	F	FA	G	J	K	M	MM	N	P	LG
Lube	125	~1,400	47	50	145	145	115	36	90	59	43	14	16	M14×1.5	15	30	M30×1.5	35	1/2	98
Non-Lube	140	~1,400	47	50	160	161	128	36	90	59	43	14	16	M14×1.5	15	24	M30×1.5	35	1/2	98
Air-Hydro	160	~1,400	53	56	180	182	144	40	90	59	43	14	18.5	M16×1.5	17	26	M36×1.5	39	3/4	106
Lube	180	~1,800	60	63	200	204	162	45	115	70	48	17	18.5	M18×1.5	20	31	M40×1.5	39	3/4	111
Lube	200	~1,800	60	63	225	226	182	50	115	74	48	17	18.5	M20×1.5	20	31	M45×1.5	39	3/4	111
Non-Lube	250	~2,000	67	71	275	277	225	60	140	86	60	20	23	M24×1.5	25	35	M56×2	49	1	141
Non-Lube	300	~2,000	76	80	330	330	270	70	140	96	60	20	23	M30×1.5	30	48	M64×2	49	1	146

Type	Bore size (mm)	φFD	FT	FK	FL	FM	Without Rod Boot		With Rod Boot				
							H	LT	φe	f	h	l	LT1
Lube	125	19	14	190	100	230	110	238	★75	40	133	0.2Stroke	261
Non-Lube	140	19	20	212	112	255	110	232	★75	40	133		255
Air-Hydro	160	19	20	236	118	275	120	252	★75	40	141		273
Lube	180	24	25	265	132	320	135	277	85	45	153	0.2Stroke	295
Lube	200	24	25	280	150	335	135	277	90	45	153		295
Non-Lube	250	29	30	355	180	420	160	336	105	55	176	0.17Stroke	352
Non-Lube	300	33	30	400	212	475	175	369	115	55	190		384

※ Minimum stroke with Rod Boot 30mm or more
 ★ Rod → Boot material : neoprene cloth-80mm

- ACP
- APM
- AS
- AX
- AM2
- AM
- AL
ALX**
- AQ
ADQ
- AQ2
ADQ2
- AJ
AJM
- ABK
- ACK1
- NSK
- AG
- NGQ
- AGX
GX
- NP
- ADR
- AMR
- NDM
- ARD
- NST
- AST
- ASTH
- NLCD
- NLCS

Series AL/ALX

Long Stroke : Foot Flange Type(ALF)

Lube Type(ALF), Non-Lube Type(ALFN), Air-Hydro Type(ALFH)

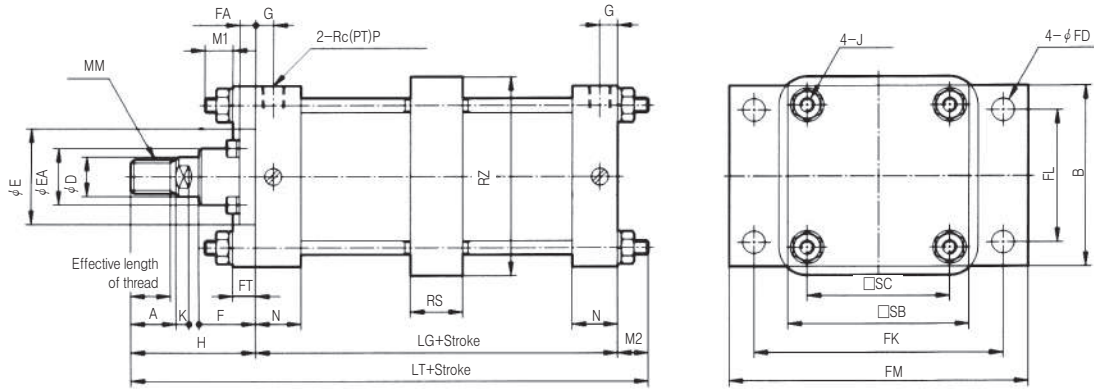

With Single Rod Boot

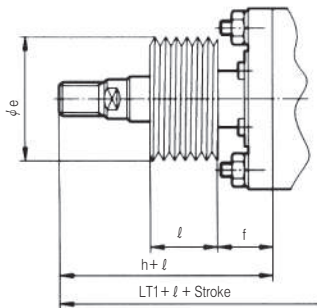

(mm)

Type	Bore-size (mm)	*Stroke range (mm)	Effective length thread	A	B	□SB	□SC	ϕ D	ϕ E	ϕ EA	F	FA	G	J	K	M ₁	M ₂	MM	N	P	LG
Lube	125	1,401~1,600	47	50	145	145	115	36	90	59	43	14	16	M14×1.5	15	22	22	M30×1.5	35	1/2	98
Non-Lube	140	1,401~1,600	47	50	160	161	128	36	90	59	43	14	16	M14×1.5	15	19	19	M30×1.5	35	1/2	98
Air-Hydro	160	1,401~1,600	53	56	180	182	144	40	90	59	43	14	18.5	M16×1.5	17	22	22	M36×1.5	39	3/4	106
Lube	180	1,801~2,000	60	63	200	204	162	45	115	70	48	17	18.5	M18×1.5	20	26	26	M40×1.5	39	3/4	111
	200	1,801~2,000	60	63	225	226	182	50	115	74	48	17	18.5	M20×1.5	20	26	26	M45×1.5	39	3/4	111
	250	2,001~2,400	67	71	275	277	225	60	140	86	60	20	23	M24×1.5	25	30	30	M56×2	49	1	141
Non-Lube	300	2,001~2,400	76	80	330	330	270	70	140	96	60	20	23	M30×1.5	30	36	36	M64×2	49	1	146

Type	Bore-size (mm)	ϕ FD	FT	FK	FL	FM	RS	RZ	Without Rod Boot		With Rod Boot					
									H	LT	ϕ e	f	h	ℓ	LT ₁	
Lube	125	19	14	190	100	230	50	164	110	230	★75	40	133			253
Non-Lube	140	19	20	212	112	255	55	184	110	227	★75	40	133	0.2Stroke		250
Air-Hydro	160	19	20	236	118	275	60	204	120	248	★75	40	141			269
Lube	180	24	25	265	132	320	59	228	135	272	85	45	153	0.2Stroke		290
	200	24	25	280	150	335	59	257	135	272	90	45	153			290
	250	29	30	355	180	420	69	325	160	331	105	55	176	0.17Stroke		347
Non-Lube	300	33	30	400	212	475	79	390	175	357	115	55	190			372

* Rod Boot Material : neoprene cloth-80mm or more

* Rod Boot Material: neoprene cloth-80mm or more

Series AL/ALX

Head Side Flange Type(ALG/ALXG)

Lube Type(ALG), Non-Lube Type(ALGN), Air-Hydro Type(ALGH)

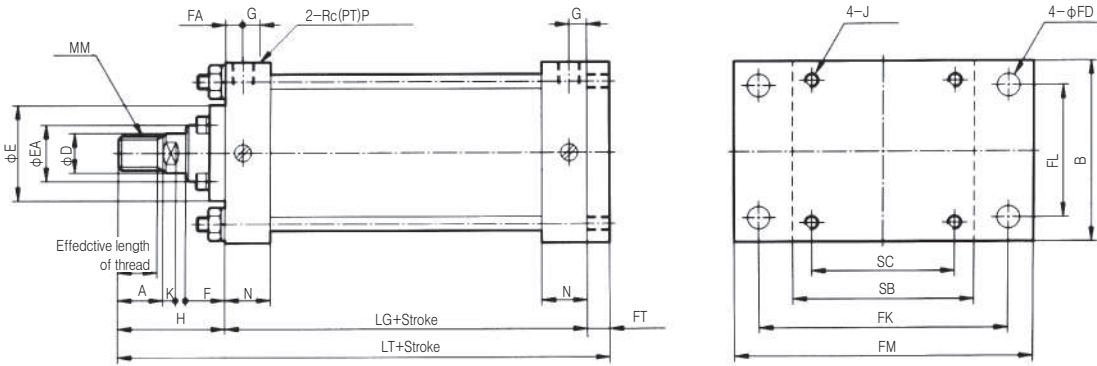

With Single Rod Boot

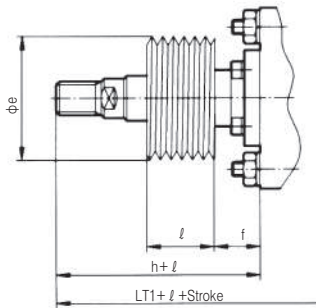

Type	Bore size (mm)	Stroke range	Effective length thread	A	B	□SB	□SC	φ D	φ E	φ EA	F	FA	G	J	K	MM	N	P	LG
Lube	125	~1000	47	50	145	145	115	36	90	59	43	14	16	M14×1.5	15	M30×1.5	35	1/2	98
Non-Lube	140	~1000	47	50	160	161	128	36	90	59	43	14	16	M14×1.5	15	M30×1.5	35	1/2	98
Air-Hydro	160	~1200	53	56	180	182	144	40	90	59	43	14	18.5	M16×1.5	17	M36×1.5	39	3/4	106
Lube Non-Lube	180	~1200	60	63	200	204	162	45	115	70	48	17	18.5	M18×1.5	20	M40×1.5	39	3/4	111
	200	~1200	60	63	225	226	182	50	115	74	48	17	18.5	M20×1.5	20	M45×1.5	39	3/4	111
	250	~1200	67	71	275	277	225	60	140	86	60	20	23	M24×1.5	25	M56×2	49	1	141
	300	~1200	76	80	330	330	270	70	140	96	60	20	23	M30×1.5	30	M64×2	49	1	146

Type	Bore size (mm)	φ FD	FT	FK	FL	FM	Without Rod Boot		With Rod Boot				
							H	LT	φ e	f	h	l	LT ₁
Lube	125	19	14	190	100	230	110	222	★75	40	133	0.2Stroke	245
Non-Lube	140	19	20	212	112	255	110	228	★75	40	133		251
Air-Hydro	160	19	20	236	118	275	120	246	★75	40	141		267
Lube Non-Lube	180	24	25	265	132	320	135	271	85	45	153	0.2Stroke	289
	200	24	25	280	150	335	135	271	90	45	153		289
	250	29	30	355	180	420	160	331	105	55	176	0.17Stroke	347
300	33	30	400	212	475	175	351	115	55	190	366		

* Rod Boot Material : neoprene cloth-80mm or more

* Rod Boot Material: neoprene cloth-80mm or more

ACP

APM

AS

AX

AM2

AM

**AL
ALX**

AQ
ADQ

AQ2
ADQ2

AJ
AJM

ABK

ACK1

NSK

AG

NGQ

AGX
GX

NP

ADR

AMR

NDM

ARD

NST

AST

ASTH

NLCD

NLCS

Series AL/ALX

Single Clevis Type/(ALC)

Lube Type(ALC), Non-Lube Type(ALCN) Air-Hydro Type(ALCH)

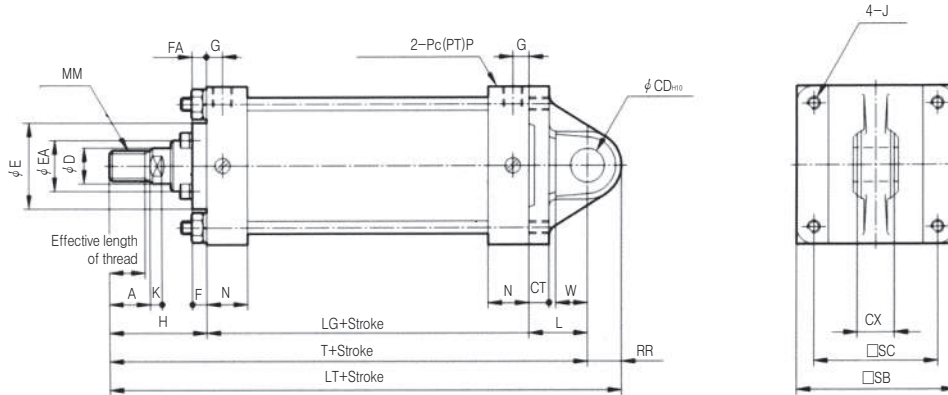

With Single Rod Boot

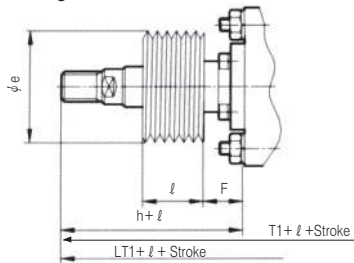

																				(mm)			
Type	Bore size (mm)	※Stroke range (mm)	Effective length thread	A	□SB	□SC	φD	φE	φEA	F	FA	G	J	K	L	MM	N	P	RR	LG			
Lube	125	~1,000	47	50	145	115	36	90	59	43	14	16	M14×1.5	15	65	M30×1.5	35	1/2	29	98			
Non-Lube	140	~1,000	47	50	161	128	36	90	59	43	14	16	M14×1.5	15	75	M30×1.5	35	1/2	32	98			
Air-Hydro	160	~1,200	53	56	182	144	40	90	59	43	14	18.5	M16×1.5	17	80	M36×1.5	39	3/4	36	106			
Lube	180	~1,200	60	63	204	162	45	115	70	48	17	18.5	M18×1.5	20	90	M40×1.5	39	3/4	44	111			
	200	~1,200	60	63	226	182	50	115	74	48	17	18.5	M20×1.5	20	90	M45×1.5	39	3/4	44	111			
	250	~1,200	67	71	277	225	60	140	86	60	20	23	M24×1.5	25	110	M56×2	49	1	55	141			
Non-Lube	300	~1,200	76	80	330	270	70	140	96	60	20	23	M30×1.5	30	130	M64×2	49	1	68	146			

Type	Bore size (mm)	W	φCD _{H10}	CT	CX	Without Rod Boot			With Rod Boot					
						H	T	LT	φe	f	h	ℓ	T ₁	LT ₁
Lube	125	35	25 ^{+0.084} ₀	17	32 ^{-0.1} _{-0.3}	110	273	302	★75	40	133	0.2Stroke	296	325
Non-Lube	140	40	28 ^{+0.084} ₀	17	36 ^{-0.1} _{-0.3}	110	283	315	★75	40	133		306	338
Air-Hydro	160	45	32 ^{+0.100} ₀	20	40 ^{-0.1} _{-0.3}	120	306	342	★75	40	141		327	363
Lube	180	50	40 ^{+0.100} ₀	23	50 ^{-0.1} _{-0.3}	135	336	380	85	45	153	0.2Stroke	354	398
	200	50	40 ^{+0.100} ₀	25	50 ^{-0.1} _{-0.3}	135	336	380	90	45	153		354	398
Non-Lube	250	65	50 ^{+0.100} ₀	30	63 ^{-0.1} _{-0.3}	160	411	466	105	55	176	0.17Stroke	427	482
	300	80	63 ^{+0.120} ₀	37	80 ^{-0.1} _{-0.3}	175	451	519	115	55	190		466	534

※ Minimum stroke with Rod Boot:30mm
 ★ Rod Boot Material: neoprene cloth-80mm or more

Series AL/ALX

Double Clevis Type/(ALD)

Lube Type(ALD), Non-Lube Type(ALDN), Air-Hydro Type(ALDH)

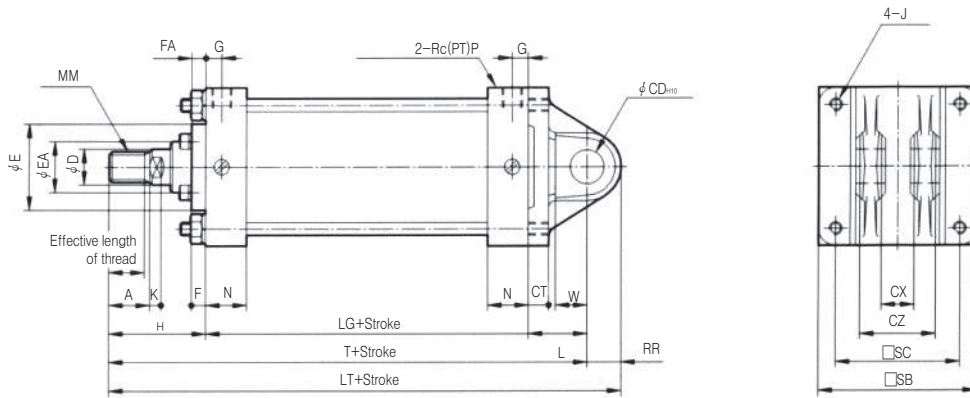

With Single Rod Boot

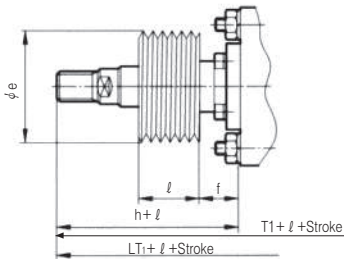

Type	Bore size (mm)	Stroke range (mm)	Effective length thread	A	□SB	□SC	φD	φE	φEA	F	FA	G	J		K	L	MM	N	P	RR	LG
													15	65							
Lube	125	~1,000	47	50	145	115	36	90	59	43	14	16	M14×1.5	15	65	M30×1.5	35	1/2	29	98	
Non-lube	140	~1,000	47	50	161	128	36	90	59	43	14	16	M14×1.5	15	75	M30×1.5	35	1/2	32	98	
Air-hydro	160	~1,200	53	56	182	144	40	90	59	43	14	18.5	M16×1.5	17	80	M36×1.5	39	3/4	36	106	
Lube	180	~1,200	60	63	204	162	45	115	70	48	17	18.5	M18×1.5	20	90	M40×1.5	39	3/4	44	111	
	200	~1,200	60	63	226	182	50	115	74	48	17	18.5	M20×1.5	20	90	M45×1.5	39	3/4	44	111	
	Non-lube	250	~1,200	67	71	277	225	60	140	86	60	20	23	M24×1.5	25	110	M56×2	49	1	55	141
	300	~1,200	76	80	330	270	70	140	96	60	20	23	M30×1.5	30	130	M64×2	49	1	68	146	

Type	Bore size (mm)	W	φCDH10	CT	CX	CZ	Without Rod Boot			With Rod Boot					
							H	T	LT	φe	f	h	l	T _i	LT _i
Lube	125	35	25 ^{+0.084} ₀	17	32 ^{+0.3} _{+0.1}	64 ⁰ _{-0.2}	110	273	302	★75	40	133	0.2 Stroke	296	325
Non-lube	140	40	28 ^{+0.084} ₀	17	36 ^{+0.3} _{+0.1}	72 ⁰ _{-0.2}	110	283	315	★75	40	133		306	338
Air-hydro	160	45	32 ^{+0.100} ₀	20	40 ^{+0.3} _{+0.1}	80 ⁰ _{-0.2}	120	306	342	★75	40	141		327	363
Lube	180	50	40 ^{+0.100} ₀	23	50 ^{+0.3} _{+0.1}	100 ^{-0.1} _{-0.3}	135	336	380	85	45	153	0.17Stroke	354	398
	200	50	40 ^{+0.100} ₀	25	50 ^{+0.3} _{+0.1}	100 ^{-0.1} _{-0.3}	135	336	380	90	45	153		354	398
	Non-lube	250	65	50 ^{+0.100} ₀	30	63 ^{+0.3} _{+0.1}	126 ^{-0.1} _{-0.3}	160	411	466	105	55		176	427
	300	80	63 ^{+0.120} ₀	37	80 ^{+0.3} _{+0.1}	160 ^{-0.1} _{-0.3}	175	451	519	115	55	190	466	534	

- ACP
- APM
- AS
- AX
- AM2
- AM
- AL**
- ALX**
- AQ
- ADQ
- AQ2
- ADQ2
- AJ
- AJM
- ABK
- ACK1
- NSK
- AG
- NGQ
- AGX
- GX
- NP
- ADR
- AMR
- NDM
- ARD
- NST
- AST
- ASTH
- NLCD
- NLCS

Series AL/ALX

Center Trunnion Type/(ALT/ALXT)

Lube Type(ALT), Non-Lube Type(ALTN) Air-Hydro Type(ALTH)

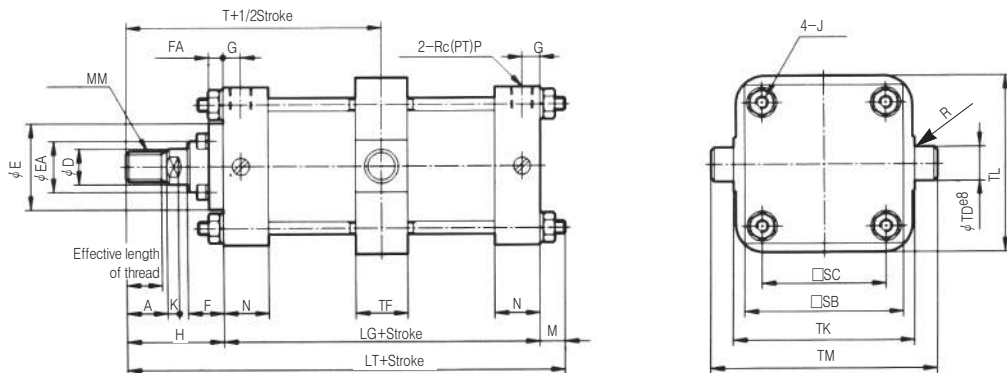

With Single Rod Boot

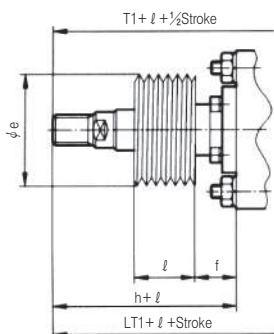

(mm)

Type	Bore size (mm)	*Stroke range (mm)	Effective length thread	A	□SB	□SC	φD	φE	φEA	F	FA	G	J	K	M	MM	N	P	R	LG
Lube	125	25~1,000	47	50	145	115	36	90	59	43	14	16	M14×1.5	15	19	M30×1.5	35	1/2	1	98
Non-lube	140	30~1,000	47	50	161	128	36	90	59	43	14	16	M14×1.5	15	19	M30×1.5	35	1/2	1.5	98
Air-hydro	160	35~1,200	53	56	182	144	40	90	59	43	14	18.5	M16×1.5	17	22	M36×1.5	39	3/4	1.5	106
Lube	180	30~1,200	60	63	204	162	45	115	70	48	17	18.5	M18×1.5	20	26	M40×1.5	39	3/4	2	111
Non-lube	200	30~1,200	60	63	226	182	50	115	74	48	17	18.5	M20×1.5	20	26	M45×1.5	39	3/4	2	111
Non-lube	250	30~1,200	67	71	277	225	60	140	86	60	20	23	M24×1.5	25	30	M56×2	49	1	3	141
Non-lube	300	35~1,200	76	80	330	270	70	140	96	60	20	23	M30×1.5	30	36	M64×2	49	1	4	146

Type	Bore size (mm)	φTDø8	TF	TK	TL	TM	Without Rod Boot			With Rod Boot						
							H	T	LT	φe	f	h	l	T ₁	LT ₁	
Lube	125	32	^{-0.050} _{-0.089}	50	170	164	234	110	159	227	★75	40	133	0.2 Stroke	182	250
Non-lube	140	36	^{-0.050} _{-0.089}	55	190	184	262	110	159	227	★75	40	133		182	250
Air-hydro	160	40	^{-0.050} _{-0.089}	60	212	204	292	120	173	248	★75	40	141		194	269
Lube	180	45	^{-0.050} _{-0.089}	59	236	228	326	135	190.5	272	85	45	153	0.2 Stroke	208.5	290
Non-lube	200	45	^{-0.050} _{-0.089}	59	265	257	355	135	190.5	272	90	45	153	Stroke	208.5	290
Non-lube	250	56	^{-0.060} _{-0.106}	69	335	325	447	160	230.5	331	105	55	176	0.17 Stroke	246.5	347
Non-lube	300	67	^{-0.060} _{-0.106}	79	400	390	534	175	248	357	115	55	190	Stroke	263	372

※ Minimum stroke with Rod Boot : 30mm
 ★ Rod Boot Material : neoprene cloth-80mm or more

Series AL/ALX

Basic Type/(ALXB)

Lube Type(ALXB), Non-Lube Type(ALXBN) Air-Hydro Type(ALXBH)

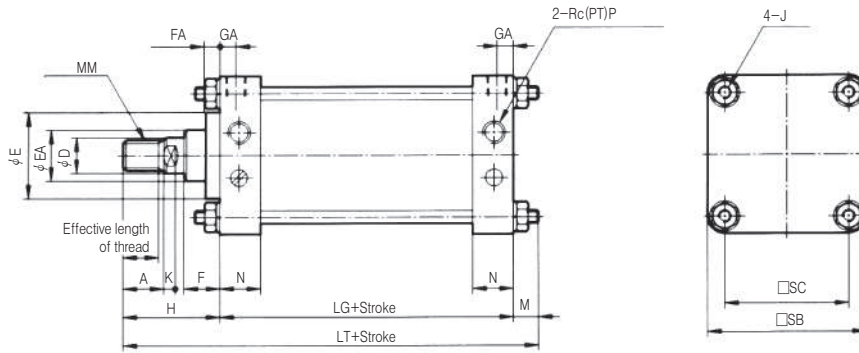

With Single Rod Boot

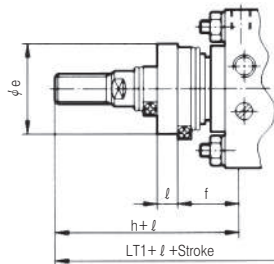

Type	Bore-size	Stroke range	Effective length of thread	A	□SB	□SC	φD	φE	φEA	F	FA	GA	GB	J	K	M	MM	N	P	LG
Lube Non-lube	125	~1,000	47	50	145	115	36	90	59	43	14	16	40	M14×1.5	15	27	M30×1.5	35	1/2	98
	140	~1,000	47	50	161	128	36	90	59	43	14	16	40	M14×1.5	15	27	M30×1.5	35	1/2	98
	160	~1,200	53	56	182	144	40	90	59	43	14	18.5	40	M16×1.5	17	30.5	M36×1.5	39	3/4	106
	180	~1,200	60	63	204	162	45	115	70	48	17	18.5	-	M18×1.5	20	35	M40×1.5	39	3/4	111
	200	~1,200	60	63	226	182	50	115	74	48	17	18.5	-	M20×1.5	20	35	M45×1.5	39	3/4	111
	250	~1,200	67	71	277	225	60	140	86	60	20	23	-	M24×1.5	25	41.5	M56×2	49	1	141
	300	~1,200	76	80	330	270	70	140	96	60	20	23	-	M30×1.5	30	51.5	M64×2	49	1	146

Type	Bore size	Without Rod Boot		With Rod Boot					With
		H	LT	φe	f	h	l	LT ₁	
Lube Non-Lube	125	110	235	★75	40	133	0.2Stroke	258	31
	140	110	235	★75	40	133		258	31
	160	120	256.5	★75	40	141		277.5	36
	180	135	281	85	45	153	0.2Stroke	299	41
	200	135	281	90	45	153		299	46
	250	160	342.5	105	55	176		358.5	56
	300	175	372.5	115	55	190	387.5	65	

※ Minimum stroke with Rod Boot:30mm
★ Rod Boot Material:neoperne cloth-80mm

- ACP
- APM
- AS
- AX
- AM2
- AM
- AL
ALX**
- AQ
ADQ
- AQ2
ADQ2
- AJ
AJM
- ABK
- ACK1
- NSK
- AG
- NGQ
- AGX
GX
- NP
- ADR
- AMR
- NDM
- ARD
- NST
- AST
- ASTH
- NLCD
- NLCS

Series ALW/ALXW

Double Rod End Type

Bore Size(mm) : Ø125, Ø140, Ø160, Ø180, Ø200, Ø250, Ø300

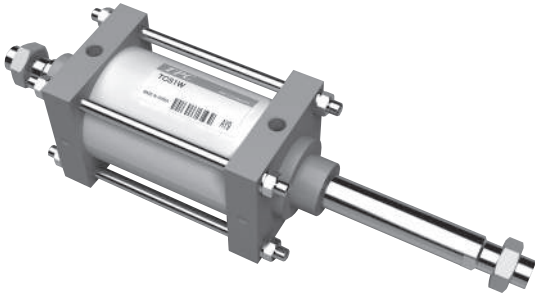

- DOUBLE ROD END CYLINDER
- ALUMINUM TUBE : ϕ 125~ ϕ 160
- IRON TUBE : ϕ 180~ ϕ 300

Symbol

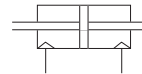

How to Order

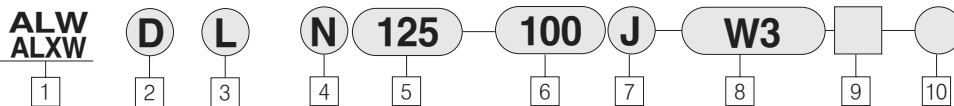

1 Double Rod End Cylinder

2 Magnet
 Blank : None
 D : Built in Magnet
 (ϕ 125, ϕ 140, ϕ 160 Only)

3 Mounting
 B : Basic Type
 L : Foot Type
 F : Front Flange
 T : Center Trunion

4 Type

5 Bore Size

6 Stroke

7 Suffix Symbol for Cylinder

8 Auto Switch

9 Number of Auto Switches

10 Series

* For details, please refer to page 206

Specifications

Type	Lube, Non-lube	Air-hydro
Fluid	Air	L.P.Oil
Proof Pressure	1.6Mpa(22psi)	
Max. Operating Pressure	0.9Mpa(140psi)	
Min. Operating Pressure	50kPa(7psi)	60kPa(8psi)
Ambient and fluid temperature	5~60°C (41~140°F)	
Piston speed	50~500mm/s	0.5~200mm/s
Cushion	With Air Cushion	Without Cushion
Mounting	Basic, Foot, Flange, Center trunion	

Series ALW/ALXW

Basic Type (ALWB)

Lube Type (ALWB),
 Non-Lube Type (ALWBN)
 Air-Hydro Type (ALWBH)

With Single Rod Boot

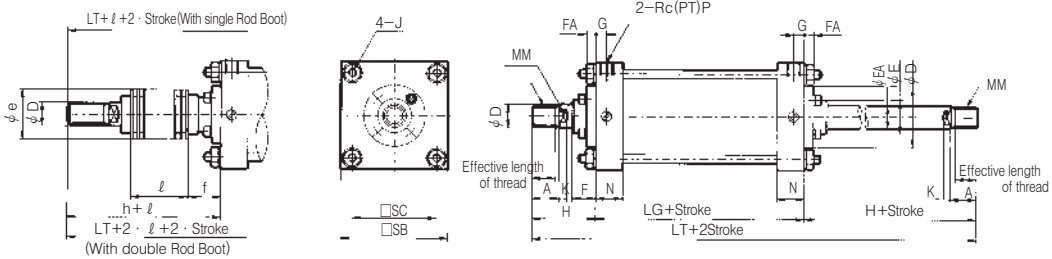

With Double Rod Boot

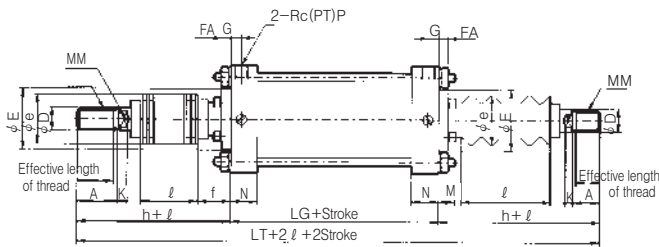

Type	Bore Size (mm)	Stroke range		Effective length of thread	A	□SB	□SC	φ D	φ E	φ EA	F	FA	G	J	K	M	MM	N	P	LG
		Without	With Rod Boot																	
Lube	125	~1,000	30~1,000	47	50	145	115	36	90	59	43	14	16	M14×1.5	15	27	M30×1.5	35	1/21	98
Non-Lube	140	~1,000	30~1,000	47	50	161	128	36	90	59	43	14	16	M14×1.5	15	27	M30×1.5	35	/2	98
Air-Hydro	160	~1,200	30~1,200	53	56	182	144	40	90	59	43	14	18.5	M16×1.5	17	30.5	M36×1.5	39	3/4	106
Lub	180	~1,200	30~1,200	60	63	204	162	45	115	70	48	17	18.5	M18×1.5	20	35	M40×1.5	39	3/4	111
	200	~1,200	30~1,200	60	63	226	182	50	115	74	48	17	18.5	M20×1.5	20	35	M45×1.5	39	3/4	111
Non-Lube	250	~1,200	30~1,200	67	71	277	225	60	140	86	60	20	23	M24×1.5	25	41.5	M56×2	49	1	141
	300	~1,200	30~1,200	76	80	330	270	70	140	96	60	20	23	M30×1.5	30	51.5	M64×2	49	1	146

★ Rod Boot Material : Neoprene cloth-80mm or more

(mm)

Type	Bore size (mm)	Without Rod Boot		With Single Rod Boot					
		H	LT	φ e	f	h	l	LT	LT
Lube	125	110	318	★75	40	133	0.2Stroke	341	364
Non-Lube	140	110	318	★75	40	133			
Air-Hydro	160	120	346	★75	40	141			
Lub	180	135	381	85	45	153	0.2Stroke	399	417
	200	135	381	90	45	153			
Non-Lube	250	160	461	105	55	176	0.17Stroke	477	493
	300	175	496	115	55	190			

ACP

APM

AS

AX

AM2

AM

AL
ALX

AQ
ADQ

AQ2
ADQ2

AJ
AJM

ABK

ACK1

NSK

AG

NGQ

AGX
GX

NP

ADR

AMR

NDM

ARD

NST

AST

ASTH

NLCD

NLCS

Series ALW/ALXW

Adjustable Stroke Cylinder/Extension Adjustable Type

AX
ALX

Mounting Tube material Type Bore size Stroke Additional symbol Stroke adjusting symbol — XC8

Additional symbol
 Blank—With Rod
 J—With Rod(Nylon tarpaulin)
 K—With Rod(Neoprene cloth)

Stroke adjusting symbol
 A—Stroke adjusting range 0--25mm
 B—Stroke adjusting range 0--50mm

The stroke at extend of the cylinder can be adjusted by the stopper in the head side from full stroke 0--25mm or 0--50mm

Symbol

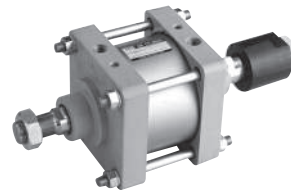
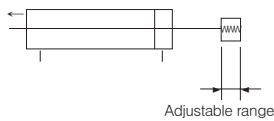

Construction, Dimensions/Basic Type

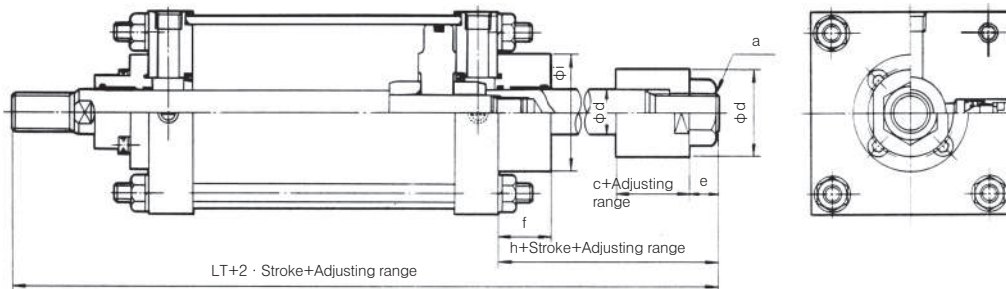

* Other dimensions are the same as standard type

Tube Size(mm)	a	Øb	c	Ød	e	f	h	Øi	LT
125	M30×1.5	70	43	36	27	40	110	90	318
140	M30×1.5	70	43	36	27	40	110	90	318
160	M30×1.5	70	43	36	27	40	110	90	336
180	M42×1.5	80	50	45	37.5	45	132.5	115	378.5
200	M42×1.5	80	50	50	37.5	45	132.5	115	378.5
250	M56×2	110	70	60	50	55	175	140	476
300	M56×2	110	70	70	50	55	175	140	496

With Coil Scraper

AX
ALX

Mounting Tube Material Type Bore Size Stroke Suffix — X104

Suffix ●
 Blank—basic — Both ends cushion
 R — Rod end cushion
 H — Head end cushion
 N — non-cushion

Bore Size	ØA	B	Bore Size	ØA	B
125	Ø50	0.8	200	Ø64	1.8
140	Ø50	0.8	250	Ø78	0.5
160	Ø50	2.8	300	Ø88	5
180	Ø60	1.8			

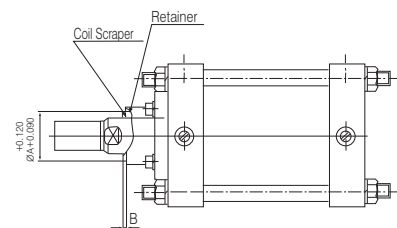

Series ALW/ALXW

Adjustable Stroke Cylinder/Retraction Adjustable Type

AL
ALX

Mounting

Tube material

Type

Bore size

Stroke

Additional symbol

Stroke adjusting symbol — XC9

● Stroke adjusting symbol
A—Stroke adjusting range 0~25mm
B—Stroke adjusting range 0~50mm

Symbol

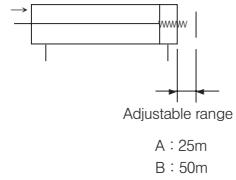

The stroke at retraction of the cylinder can be adjusted from 0~25mm or 0~50mm by the adjusting bolt.

Construction, Dimensions/Basic Type

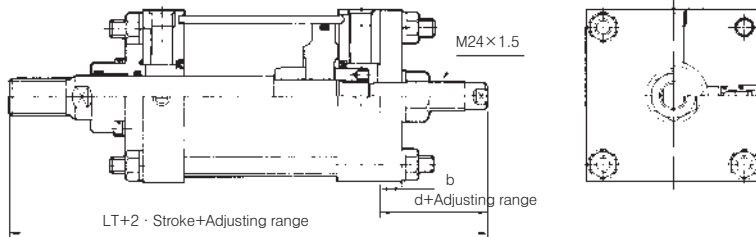

(mm)

Bore size	b	d	LT
125	19	66	274
140	19	66	274
160	22	62	288

※ Other dimensions are the same as standard type

ACP

APM

AS

AX

AM2

AM

**AL
ALX**

AQ
ADQ

AQ2
ADQ2

AJ
AJM

ABK

ACK1

NSK

AG

NGQ

AGX
GX

NP

ADR

AMR

NDM

ARD

NST

AST

ASTH

NLCD

NLCS

Series ALW/ALXW

Dual Stroke Cylinder/Double Rod Type

AL (Mounting) (Tube material) (Type) (Bore size) (Stroke A) (Additional symbol) + (Stroke B) (Additional symbol) -XC10
 ALX

Two cylinders are constructed as one cylinder in a back-to-back configuration allowing the cylinder stroke to be controlled in three steps.

Construction, Dimensions/Basic Type

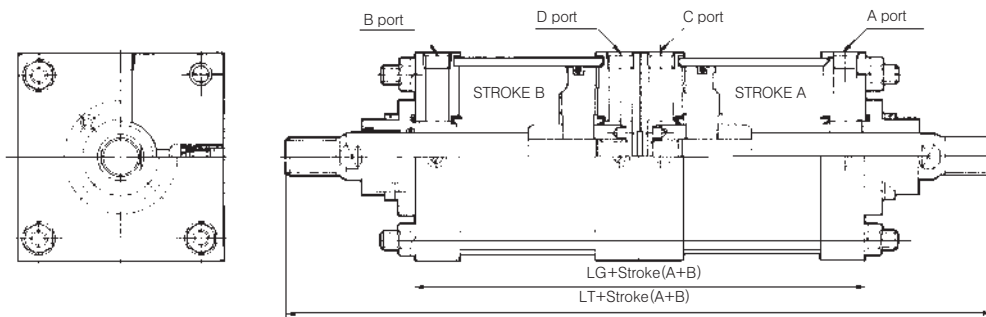

Bore size(mm)	LG	LT
125	196	416
140	196	416
160	212	452
180	212	492
200	222	492
250	282	602
300	292	642

※ Other dimensions are the same as standard type

Dual Stroke Cylinder/Single Rod Type

AL (Mounting) (Tube material) (Type) (Bore size) (Stroke A) (Additional symbol) + (Stroke B-A) (Additional symbol) -XC11
 ALX

Additional Rod Boot ●
 Blank-Without Rod Boot
 J-With Rod Boot(Nylon tarpaulin)
 K-With Rod Boot(Neoprene cloth)

Construction, Dimensions/Basic Type

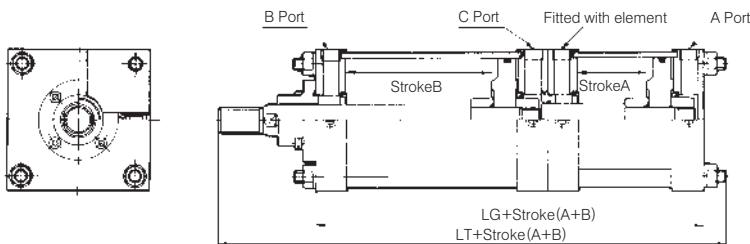

Bore size	LG	LT
125	197	334
140	197	334
160	213	363.5
180	223	393
200	223	393
250	283	484.5
300	293	519.5

※ Other dimensions are the same as standard type

Series ALW/ALXW

High Temperature Cylinder

AL
ALX

Mounting — Tube material — Bore Size — Stroke — suffix — XB6

Suffix ●
 Blank — Both sides Attached Air Cushion
 R — Rod End Air Cushion
 H — Head End Air Cushion
 N — Non-cushion

Specification

Type	Non-Lube
Bore Size	φ 125, φ 140, φ 160, φ 180, φ 200
Ambient Temperature Condition	-20~+150°C (-4~302°F)
Packing material	FPM(Fluorine)

Can be used at high temperature up to 150°C (302°F)

Piston Rod Stainless

AL
ALX

Mounting — Tube material — Type — Bore Size — Stroke — suffix — XC6

Suffix ●
 Blank — Both sides Attached Air Cushion
 R — Rod End Air Cushion
 H — Head End Air Cushion
 N — Non-cushion

Auto Switch Mounting Available

Type	Lube, Non-Lube, Air Hydro
Bore Size	φ 125, φ 140, φ 160, φ 180, φ 200, φ 250, φ 300
Piston Material	Stainless steel (SUS304)

Stainless steel piston rod is used to protect in harsh or wet environment

ACP

APM

AS

AX

AM2

AM

AL
ALX

AQ
ADQ

AQ2
ADQ2

AJ
AJM

ABK

ACK1

NSK

AG

NGQ

AGX
GX

NP

ADR

AMR

NDM

ARD

NST

AST

ASTH

NLCD

NLCS

Series ALW/ALXW

Built in Coil Scraper

AL (Mounting) (Tube material) (Type) (Bore size) (Stroke) (Suffix) X104
 ALX

Suffix

- Blank — Standard (Air Cushion)
- R — Rod End Air Cushion
- H — Head End Air Cushion
- N — Non — Cushion

Bore Size	ϕ A	B	Bore Size	ϕ A	B
125	ϕ 50	0.8	200	ϕ 64	1.8
140	ϕ 50	0.8	250	ϕ 78	0.5
160	ϕ 50	2.8	300	ϕ 88	5
180	ϕ 60	1.8			

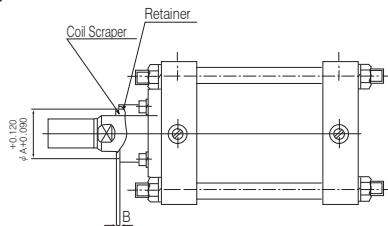

With Strong Scraper

AL (Mounting) (Tube material) (Type) (Bore size) (Stroke) (Additional symbol) XC4
 ALX

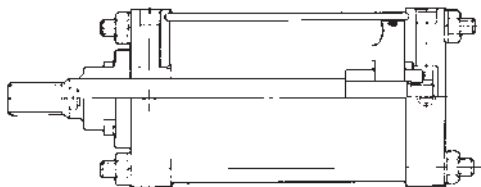

※ Dimensions are the same as standard type.

Oversized Rod Cylinder

AL (Mounting) (Type) (Bore size) (Stroke) (Suffix) XB5
 ALX

Suffix

- Blank — Both sides Attached Air Cushion
- R — Rod End Air Cushion
- H — Head End Air Cushion
- N — Non — Cushion

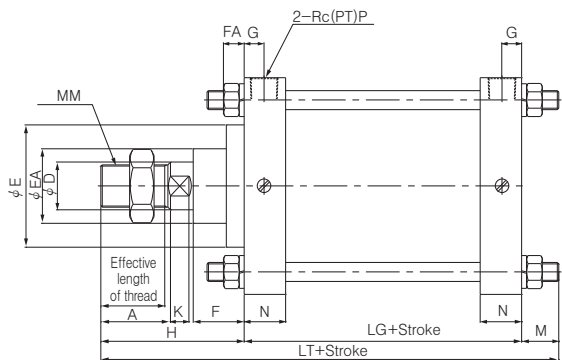

Type	Lube, Non-lube				
Bore size(mm)	125	140	160	180	200
Piston rod diameter(mm)	50	60	60	70	70

(mm)

Bore Size	A	ϕ D	ϕ E	ϕ EA	F	K	MM	H	LT
125	63	50	115	74	48	20	M45×1.5	135	260
140	71	60	140	86	60	25	M56×2	160	285
160	71	60	140	86	60	25	M56×2	160	296.5
180	80	70	140	96	60	30	M64×2	175	321
200	80	70	140	96	60	30	M64×2	175	321

※ Dimensions are the same as Standard type.

Series ALW/ALXW

Auto Switch Mounting Position (At stroke End)

W3

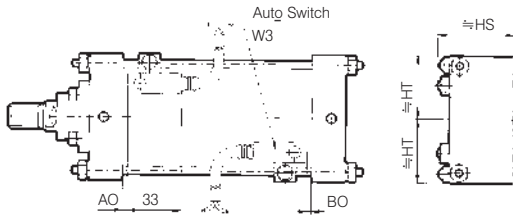

Auto s/w model	Auto s/w Mounting Position	Auto s/w placement dimensions(mm)		
		125	140	160
W3	AO	0	0	0
	BO	0	0	0
	≠HS	75.5	82.0	90.0
	≠HT	70.0	76.5	87.0

Minimum Auto Switch Mountable Stroke

Auto switch model	No. of Auto Switch	Mounting bracket except trunnion	n:No. of Auto Switch		
			φ 125	φ 140	φ 160
W3	with 2 switches (different, same surface) with 1 switch	25	125	135	135
	with n switches (same surface bracket)	$125+55(\frac{n-2}{2})$ <small>n=4,8,12,16,...</small>	$125+55(\frac{n-4}{2})$ <small>n=4,8,12,16,...</small>	$135+55(\frac{n-4}{2})$ <small>n=4,8,12,16,...</small>	

Bracket

Knuckle Joint pin/Clevis Pin

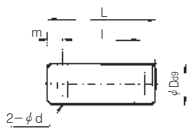

Material:Carbon steel

Part No.	Applicable bore(mm)	φ Dd9	L	ℓ	m	φ d	Applicable split pin
TY-12	125	25 ^{-0.065} _{-0.117}	81.5	69.5	6	4	φ 4×40
TY-14	140	28 ^{-0.065} _{-0.117}	94.5	76.5	9	4	φ 4×40
TY-16	160	32 ^{-0.080} _{-0.142}	94.5	84.5	9	4	φ 4×40
TY-18	180 · 200	40 ^{-0.080} _{-0.142}	125	105	10	4	φ 4×55
TY-25	250	50 ^{-0.080} _{-0.142}	156	132	12	5	φ 5×65
TY-30	300	63 ^{-0.100} _{-0.174}	190	166	12	5	φ 5×80

I type single knuckle Joint

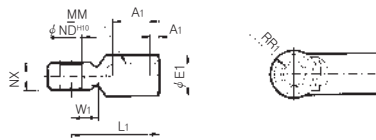

Material:Cast iron

Part No.	Applicable bore(mm)	A ₁	A ₂	φ E ₁	L ₁	MM	φ ND ^{H10}	NX	RR ₁	W ₁
TI-12	125	8	54	46	100	M30×1.5	25 ^{+0.084} ₀	32 ^{-0.1} _{-0.3}	27	33
TI-14	140	8	54	48	105	M30×1.5	28 ^{+0.084} ₀	36 ^{-0.1} _{-0.3}	30	39
TI-16	160	8	60	55	110	M36×1.5	32 ^{+0.1} ₀	40 ^{-0.1} _{-0.3}	34	39
TI-18	180	8	67	70	125	M40×1.5	40 ^{+0.1} ₀	50 ^{-0.1} _{-0.3}	42.5	44
TI-20	200	8	67	70	125	M45×1.5	40 ^{+0.1} ₀	50 ^{-0.1} _{-0.3}	42.5	44
TI-25	250	9	75.5	86	160	M56×2	50 ^{+0.1} ₀	63 ^{-0.1} _{-0.3}	53	66
TI-30	300	9	84.5	105	175	M64×2	63 ^{+0.12} ₀	80 ^{-0.1} _{-0.3}	66	71

Rod End Nut

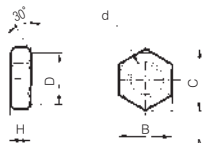

Material:Rolled steel

Part No.	Applicable bore(mm)	d	H	B	C	D
TNT-12	125 · 140	M30×1.5	18	46	53.1	44
TNT-16	160	M36×1.5	21	55	63.5	53
TNT-18	180	M40×1.5	23	60	69.3	57
TNT-20	200	M45×1.5	27	70	80.8	67
TNT-25	250	M56×2	34	85	98.1	82
TNT-30	300	M64×2	38	95	110.0	92

Y Type Double Knuckle Joint

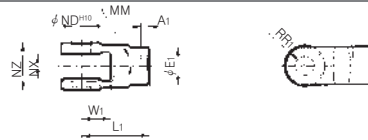

Material:Cast iron

Part No.	Applicable bore(mm)	A ₁	φ E ₁	L ₁	MM	φ ND ^{H10}	NX	NZRR ₁	W ₁	
TY-12A	125	8	46	100	M30×1.5	25 ^{+0.084} ₀	32 ^{+0.3} _{+0.1}	64 ^{-0.1} _{-0.3}	27	42
TY-14A	140	8	48	105	M30×1.5	28 ^{+0.084} ₀	36 ^{+0.3} _{+0.1}	72 ^{-0.1} _{-0.3}	30	47
TY-16A	160	8	55	110	M36×1.5	32 ^{+0.1} ₀	40 ^{+0.3} _{+0.1}	80 ^{-0.1} _{-0.3}	34	46
TY-18A	180	8	70	125	M40×1.5	40 ^{+0.1} ₀	50 ^{+0.3} _{+0.1}	100 ^{-0.1} _{-0.3}	42.5	54
TY-20A	200	8	70	125	M45×1.5	40 ^{+0.1} ₀	50 ^{+0.3} _{+0.1}	100 ^{-0.1} _{-0.3}	42.5	54
TY-25A	250	9	86	160	M56×2	50 ^{+0.1} ₀	63 ^{+0.3} _{+0.1}	126 ^{-0.1} _{-0.3}	53	81
TY-30A	300	9	105	175	M64×2	63 ^{+0.12} ₀	80 ^{+0.3} _{+0.1}	160 ^{-0.1} _{-0.3}	66	87

ACP

APM

AS

AX

AM2

AM

AL
ALX

AQ
ADQ

AQ2
ADQ2

AJ
AJM

ABK

ACK1

NSK

AG

NGQ

AGX
GX

NP

ADR

AMR

NDM

ARD

NST

AST

ASTH

NLCD

NLCS